



LOVE
CERAMIC TILES



2016

A mudança estratégica projeta-nos onde somente sabemos estar. Distinguir, atualizar e modernizar são conceitos que nos lideram nos processos de design, gestão e produção. Só assim nos realizaremos, apresentando um versátil leque de produtos de qualidade e excelência incontornáveis. Do rústico ao sofisticado, a LOVE TILES conhece bem o posicionamento da sua criação.

SOMOS O QUE DESEJAMOS.

Strategic change positions us exactly where we want to be. Distinction, Renewal and Modernisation are the guiding concepts underlying our design, management and production processes. Our accomplishment and fulfilment can only be achieved by applying such concepts to our wide range of products of undeniable quality and excellence. From rustic preferences to more sophisticated tastes, the position which LOVE TILES' creativity occupies is well known.

WE ARE WHAT WE CHOOSE TO BE.

Le changement stratégique nous projette dans la seule place que nous connaissons. Distinguer, actualiser et moderniser sont les concepts qui nous guident dans le design, dans la gestion et dans la production. Voilà notre seule façon de réussir: la présentation d'un éventail varié de produits de qualité et d'excellence incontournables. Du rustique au plus raffiné, LOVE TILES connaît bien la place qui occupe sa création.

NOUS SOMMES CE QUE NOUS VOULONS.



Die strategische Änderung positioniert uns genau dort, wo wir sein möchten. Differenzierung, Aktualisierung und Modernisierung sind Konzepte, die uns bei den Design-, Management- und Herstellungsprozessen leiten. Nur so werden wir unsere Ziele erreichen, die unserem breit gefächertes Angebot an qualitativ hochwertigen Produkten präsentieren zugrunde liegen. Von rustikalen bis zu hochentwickelten Elementen, LOVE TILES kennt die Positionierung seiner Produkte sehr gut.

WIR SIND WAS WIR WÜNSCHEN.

Стратегические изменения позиционируют нас именно там, где мы умеем и хотим находиться. Отличия, обновления и модернизация являются нашими основными принципами в процессах проектирования, управления и производства. Только так мы сможем достичь собственной реализации, представляя универсальный ассортимент продукции неоспоримого качества и совершенства. Дизайн серии love tiles, простой или более изысканный, заслуживает особого внимания.

МЫ ТЕ, КЕМ ХОТИМ БЫТЬ!



LOVE
CERAMIC TILES

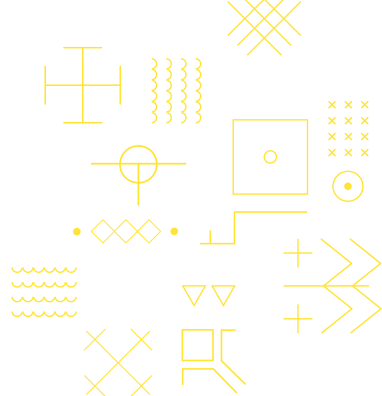

ÍNDICE

INDEX

ОГЛАВЛЕНИЕ



79	ACQUA	299	PIRINÉUS
303	ARGEL	251	PLACE
53	AROMA	153	PLAZA
179	ATELIER	11	PRECIOSUS
75	BLEND	169	ROYALE
289	CANYON	277	SOUL
123	CHARM	303	TEJO
143	DELUXE	295	TOSCANO
187	DREAMS	303	TURIM
213	EMMA	23	URBAN
247	ESSENCE	241	VISION
283	FEVER	259	WILDWOOD
269	FUSION	129	WONDER
197	LIGHT		
205	LOFT		
39	NEST		
101	PARFUM		

8	COLOUR-MAP
308	NON-SLIPPERY
312	TECHNICAL INFORMATION
321	NF UPEC
322	PACKAGE
324	LOVE GREEN



ÍNDICE INDEX ОГЛАВЛЕНИЕ



RETIFICADO

Rectified | Rectifié | Rectifiziert | Ректифицированный

35x100

018. PRECIOUS 032. URBAN 048. NEST 064. AROMA 091. ACQUA 110. PARFUM 125. CHARM
129. WONDER 146. DELUXE 162. PLAZA 173. ROYALE 182. ATELIER 191. DREAMS 201. LIGHT

35x70

129. PRECIOUS 146. DELUXE 162. PLAZA 173. ROYALE 201. LIGHT

30x60

48. NEST 201. LIGHT 210. LOFT 218. EMMA 280. SOUL



RETIFICADO

Rectified | Rectifié | Rectifiziert | Ректифицированный

60x60

18. PRECIOUS 48. NEST 201. LIGHT 256. PLACE

50x50

77. BLEND 280. SOUL

45x45

146. DELUXE 162. PLAZA 218. EMMA

30x60

32. URBAN 201. LIGHT 256. PLACE

35x35

125. CHARM 146. DELUXE 162. PLAZA 173. ROYALE 201. LIGHT



NÃO RETIFICADO

Non-Rectified | Non Rectifié | Nicht Rektifiziert | Не Ректифицированный

30x60

32. URBAN 48. NEST 91. ACQUA 201. LIGHT 210. LOFT 218. EMMA 280. SOUL

20x60

64. AROMA 232. GROUND

22x45

91. ACQUA 110. PARFUM 139. WONDER 146. DELUXE 162. PLAZA 173. ROYALE 182. ATELIER
191. DREAMS 201. LIGHT 245. VISION

22x33

249. ESSENCE



NÃO RETIFICADO

Non-Rectified | Non Rectifié | Nicht Rektifiziert | Не Ректифицированный

60x60

48. NEST 232. GROUND 256. PLACE 293. CANYON

50x50

77. BLEND 280. SOUL 293. CANYON

45x45

146. DELUXE 162. PLAZA 173. ROYALE 182. ATELIER 218. EMMA 232. GROUND 245. VISION 256. PLACE
286. FEVER 306. ARGEL 306. TURIM 307. TEJO

30x60

48. NEST 232. GROUND 256. PLACE

33x50

293. CANYON 297. TOSCANO 301. PIRINÉUS

15x75

266. WILDWOOD 274. FUSION

33x33

249. ESSENCE 280. SOUL 293. CANYON 297. TOSCANO 301. PIRINÉUS 306. TURIM 307. TEJO

16x33







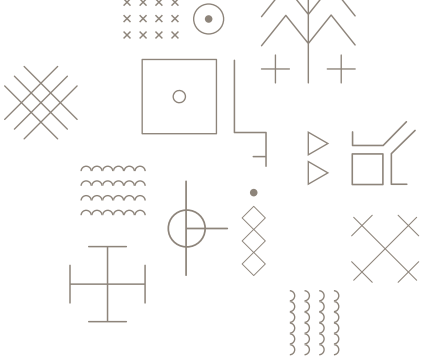



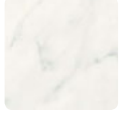

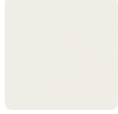
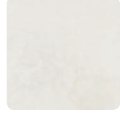
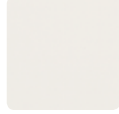
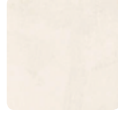
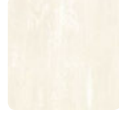
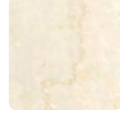

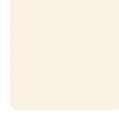
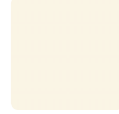
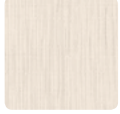
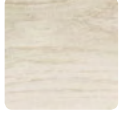
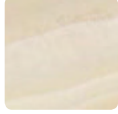
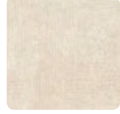
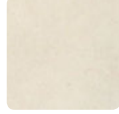
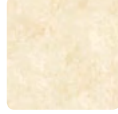

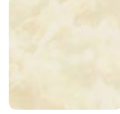
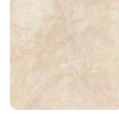
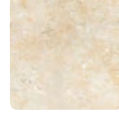
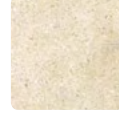

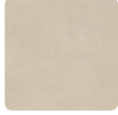
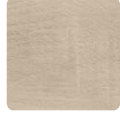
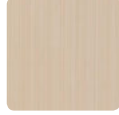

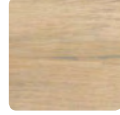
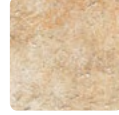
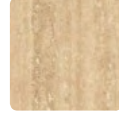
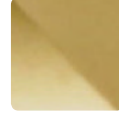

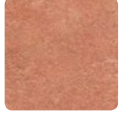

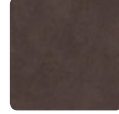
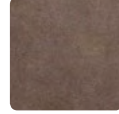
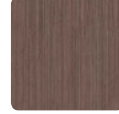
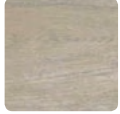

297. TOSCANO 301. PIRINÉUS

16x16

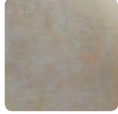
297. TOSCANO 301. PIRINÉUS

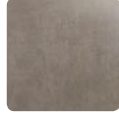
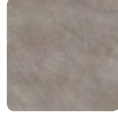
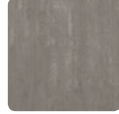
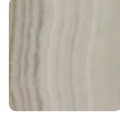
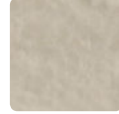
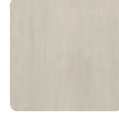
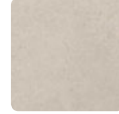

COLOUR MAP

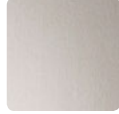
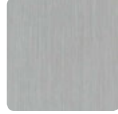
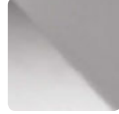
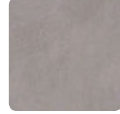
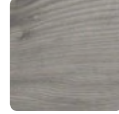
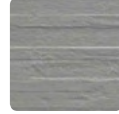
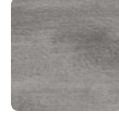
										
DELUXE CARRARA P.146	DREAMS NEVE P.191	LIGHT MATT WHITE P.201	TURIM CINZA P.306	WONDER MATT WHITE P.139	BLEND WHITE P.077	SOUL FEEL WHITE P.280	PLAZA BOTTICINO BIANCO P.162	PARFUM JASMIN BLANC P.110	LIGHT PÉROLA MATE P.201	LIGHT PÉROLA BRILHO P.201
										
ATELIER ALPIN CRÈME P.182	FUSION WHITE P.274	CHARM BEIGE P.125	PLACE WHITE P.256	FEVER INTENSE WHITE P.286	PLAZA LUXURY LIGHT P.162	PARFUM VANILLE P.110	DELUXE ONICE P.146	TEJO BEIGE P.307	ARGEL BEIGE P.306	NEST BEIGE P.048
										
WILDWOOD WHITE P.266	ACQUA BEIGE P.091	BLEND BEIGE P.077	WILDWOOD BEIGE P.266	EMMA CREAM P.218	PARFUM CANNELLE P.110	EMMA COOKIES P.218	FUSION BEIGE P.274	TOSCANO BEIGE P.297	ROYALE TRAVERTINO NOCE P.173	WONDER GOLD P.139
										
PIRINÉUS MEL P.301	PIRINÉUS MARRON P.301	AROMA PAPAYA P.065	DREAMS LARANJA P.191	DREAMS CEREJA P.191	ACQUA RUBI P.091	DREAMS CHOCOLATE P.191	ATELIER DRAPEAU MARRON P.182	BLEND BROWN P.077	FEVER SPICY BROWN P.286	ESSENCE BROWN P.249
										
FUSION TORTORA P.274	EMMA EARL GREY P.219	VISION LIGHT GREY P.245	EMMA MOCHA P.218	VISION GREY P.245	GROUND GREY P.233	SOUL PASSION ANTRACITE P.281	CHARM GREY P.125	GROUND LIGHT GREY P.233	SOUL FLOW GREY P.280	FEVER BURN GREY P.287
										
PLACE LIGHT GREY P.257	ACQUA GRIGIO P.091	WILDWOOD LIGHT GREY P.266	PARFUM AMBRE GRIS P.110	WONDER MATT CHROME P.139	ESSENCE GREY P.249	WONDER MIRROR P.139	BLEND GREY P.077	FUSION GREY P.274	LOFT GREY P.210	WILDWOOD GREY P.266

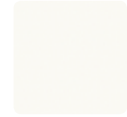

LIGHT
BRANCO BRILHO
P.201

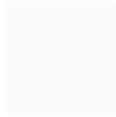

WONDER
WHITE
P.139



PRECIOUS
CALACATTA
P.018

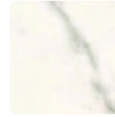

PLAZA
STATUARIO
P.162

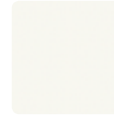

LIGHT
BRANCO MATE
P.201



ACQUA
BIANCO
P.091

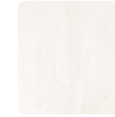

AROMA
SALT
P.065

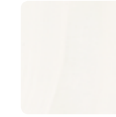

CHARM
WHITE
P.125

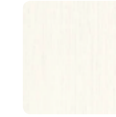

ESSENCE
WHITE
P.249

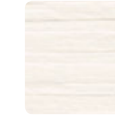

LOFT
WHITE
P.210

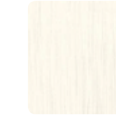

ATELIER
DIAMANT BLANC
P.182

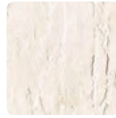

URBAN
SLATE WHITE
P.032



DREAMS
PÉROLA
P.191

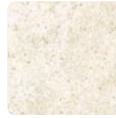

NEST
WHITE
P.048

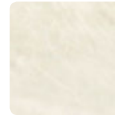

GROUND
WHITE
P.232

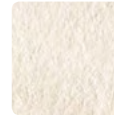

URBAN
ROUGH WHITE
P.032

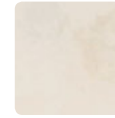

TURIM
BEIGE
P.306



URBAN
STRIPES WHITE
P.032

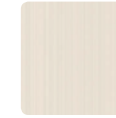

EMMA
COCONUT
P.219

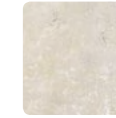

ARGEL
CINZA
P.306

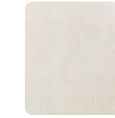

VISION
WHITE
P.245

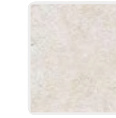

PIRINÉUS
PÉROLA
P.301

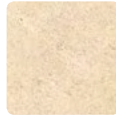

ROYALE
LIPICA BEIGE
P.173



CANYON
IVORY
P.293

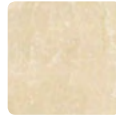

PLAZA
BOTTICINO CLASSICO
P.162

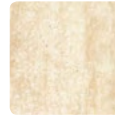

ROYALE
TRAV. BIANCO
P.173



URBAN
STRIPES BEIGE
P.033

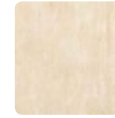

SOUL
SPIRIT PEARL
P.280

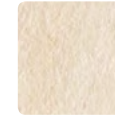

URBAN
ROUGH BEIGE
P.033

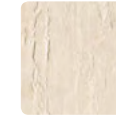

URBAN
SLATE BEIGE
P.033

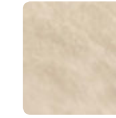

GROUND
CREAM
P.232

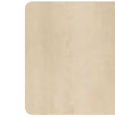

AROMA
VANILLA
P.065

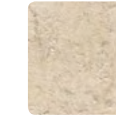

TOSCANO
PÉROLA
P.297



DREAMS
GREEN
P.191



EMMA
MINT
P.219



ACQUA
TURCHESE
P.091



AROMA
OREGANO
P.064

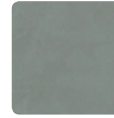

BLEND
GREEN
P.077



AROMA
BLUEBERRY
P.064



PARFUM
LYS BLEU
P.110



DREAMS
CIELO
P.191



EMMA
BUBBLE GUM
P.218



PARFUM
LAVANDE
P.110

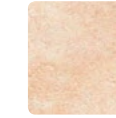

PIRINÉUS
ROSADO
P.301

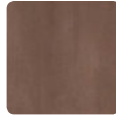

AROMA
COFFEE
P.065

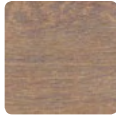

FUSION
BROWN
P.274

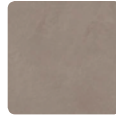

BLEND
TORTORA
P.077

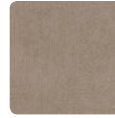

PLACE
TORTORA
P.256

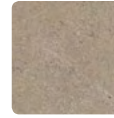

ROYALE
LIPICA GREY
P.173

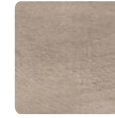

WILDWOOD
TORTORA
P.266



ESSENCE
TORTORA
P.249

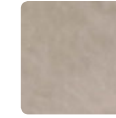

GROUND
TORTORA
P.232

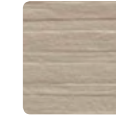

LOFT
TORTORA
P.210

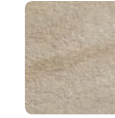

CANYON
SAND
P.293

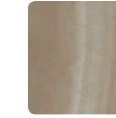

CHARM
BROWN
P.125



CANYON
GREY
P.293



LOFT
LIGHT GREY
P.210

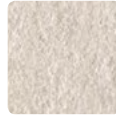

URBAN
ROUGH GREY
P.034



NEST
GREY
P.048

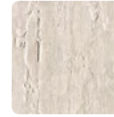

URBAN
SLATE GREY
P.034

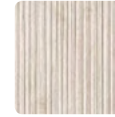

URBAN
STRIPES GREY
P.034

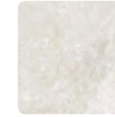

TEJO
VERDE ÁGUA
P.307



ESSENCE
LIGHT GREY
P.229

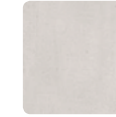

AROMA
EARL GREY
P.064



DREAMS
CINZA
P.191

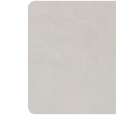

BLEND
LIGHT GREY
P.077



PLACE
GREY
P.257



ESSENCE
ANTRACITE
P.249



PLACE
ANTRACITE
P.257



EMMA
BLACK SESAME
P.219

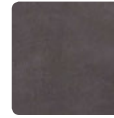

BLEND
DARK GREY
P.077



FEVER
HOT BLACK
P.287



SOUL
BODY BLACK
P.281



ACQUA
NERO
P.091

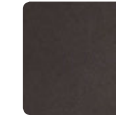

FEVER
DEEP DARK
P.287

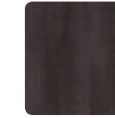

AROMA
BLACK PEPPER
P.064



WONDER
BLACK
P.141







Coleção
Collection
Kollektion
Коллекция

PRECIOUS



REVESTIMENTO COM ACABAMENTO BRILHO
GLOSSY WALL TILES
FAIÂNCES AVEC FINITION BRILLANT
WANDFLIESEN - GLÄNZEND OBERFLÄCHE
НАСТЕННАЯ КЕРАМИЧЕСКАЯ ПЛИТКА С ГЛЯНЦЕВЫМ ПОКРЫТИЕМ



REVESTIMENTO COM ACABAMENTO MATE OU SEMI-BRILHO
MATT OR SEMI-GLOSS WALL TILES
FAIÂNCES EN FINITION MAT OU SEMI-BRILLANT
WANDFLIESEN - MATT ODER HALBMATT OBERFLÄCHE
НАСТЕННАЯ КЕРАМИЧЕСКАЯ ПЛИТКА С МАТОВЫМ ИЛИ ПОЛУ-ГЛЯНЦЕВЫМ ПОКРЫТИЕМ



35x100 

35x70 

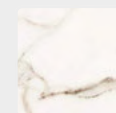

PAVIMENTO COM ACABAMENTO POLIDO
FLOOR TILES WITH POLISHED FINISH
REVÊTEMENT DE SOL AVEC FINITION POLIE
BODENBELAG MIT POLIERTER OBERFLÄCHE
ПОЛИРОВАННАЯ ПОВЕРХНОСТЬ



PAVIMENTO COM ACABAMENTO BRILHO OU SATINADO
FLOOR TILES WITH BRIGHT OR HONED FINISH
REVÊTEMENT DE SOL AVEC FINITION BRILLANTE OU SATINÉE
BODENBELAG MIT GLÄNZENDER ODER MATTER OBERFLÄCHE
ПОВЕРХНОСТЬ С ГЛЯНЦЕВЫМ ИЛИ МАТОВЫМ ПОКРЫТИЕМ



60x60 

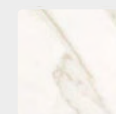

CALACATTA

PRECIOUS





PRECIOUS





PRECIOUS





PRECIOUS

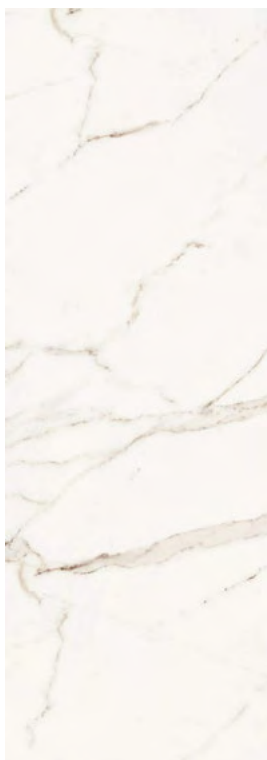

✳ CALACATTA
35X100 RET.
35X70 RET.

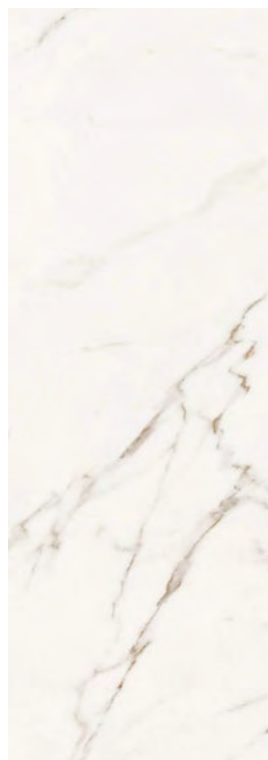

✳ CALACATTA MATT
35X100 RET.
35X70 RET.



✳ PERFIL PRECIOS CALACATTA
1,7X50
1,7X35

PERFIL PRECIOS CALACATTA
MATT
1,7X50
1,7X35

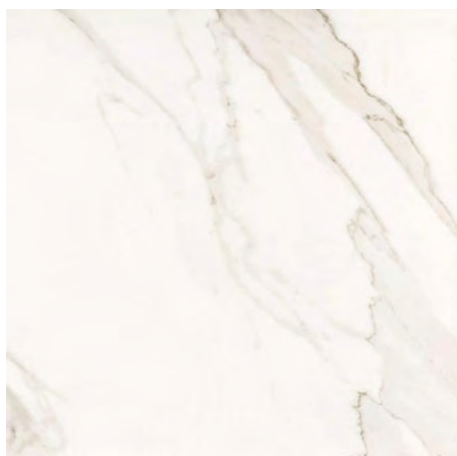

✳ CALACATTA POL.
59,2X59,2 RET.

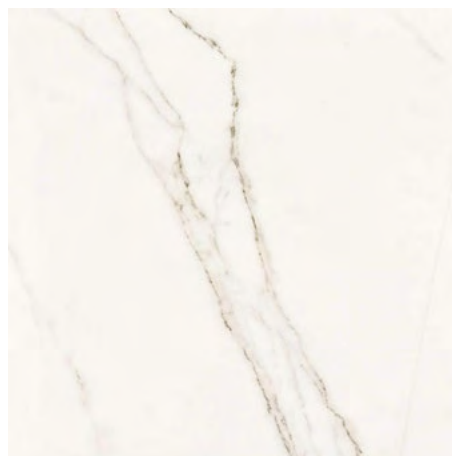

✳ CALACATTA AMA.
59,2X59,2 RET.



✳ RODAPÉ PRECIOS CALACATTA POL.
8X59,2 RET.
✳ RODAPÉ PRECIOS CALACATTA AMA.
8X59,2 RET.



SHAPE



FLOW



CURL



5X100
3X70
1,5X35

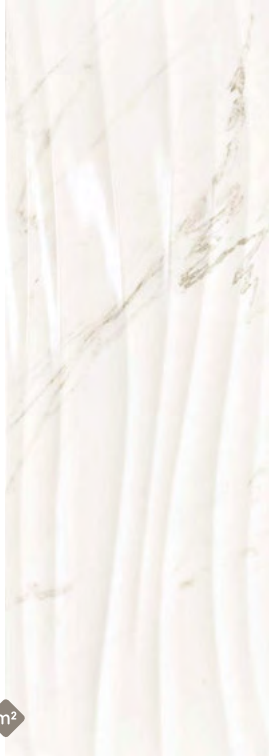

m²

× **SHAPE CALACATTA**
35X100 RET.

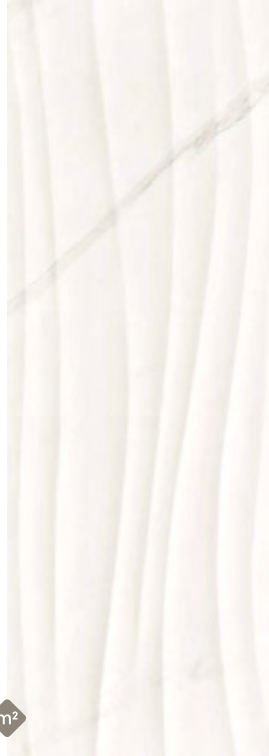

m²

× **SHAPE CALACATTA MATT**
35X100 RET.

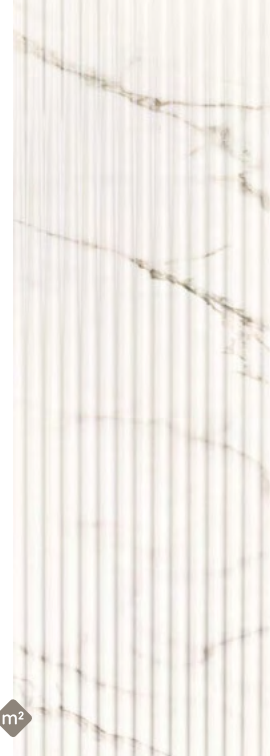

m²

× **FLOW CALACATTA**
35X100 RET.



m²

× **FLOW CALACATTA MATT**
35X100 RET.



m²

× **CURL CALACATTA**
35X70 RET.



m²

× **CURL CALACATTA MATT**
35X70 RET.



× **LISTELO PRECIOUS**
5X100



× **LISTELO PRECIOUS**
3X70



× **LISTELO GOLD**
1,5X35

PRECIOUS



✕ SUPERB CALACATTA
35X100 RET.

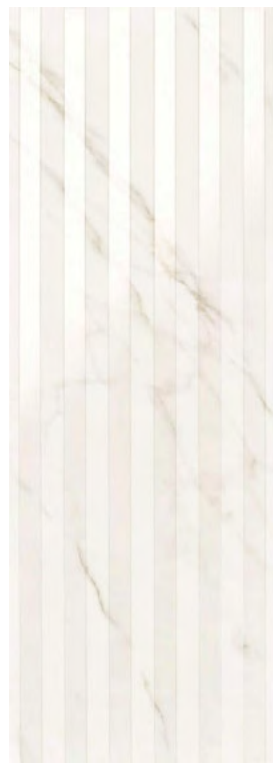

✕ SUPERB CALACATTA MATT
35X100 RET.



✕ GORGEOUS CALACATTA
35X100 RET.



✕ BELOVED CALACATTA
35X100 RET.



✕ SUPERB CALACATTA
35X70 RET.



✕ SUPERB CALACATTA MATT
35X70 RET.

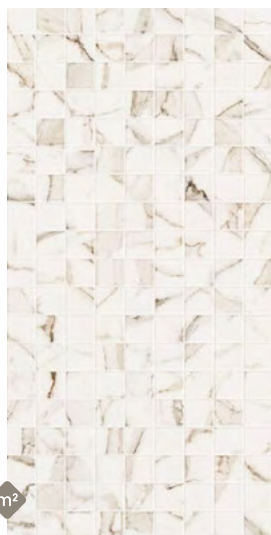

✕ BOXY CALACATTA
35X70 RET.

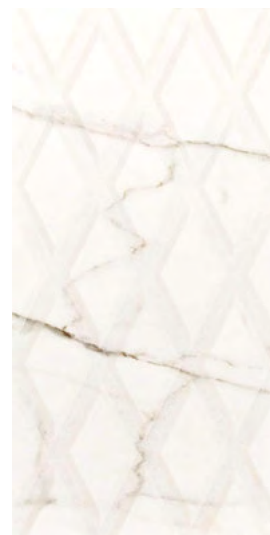

✕ TENDER CALACATTA
35X70 RET.

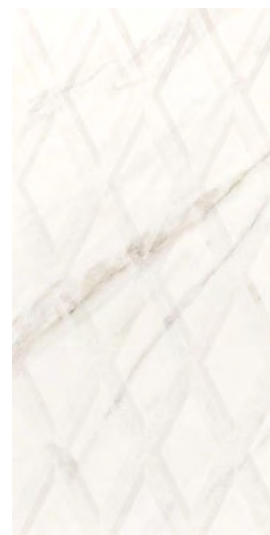

✕ TENDER CALACATTA MATT
35X70 RET.

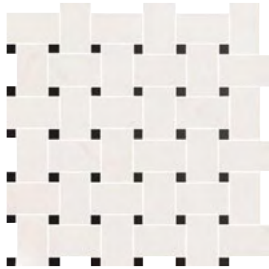

✕ **MOSAIC TIE CALACATTA**
35X35



✕ **MOSAIC HEXAGON MIX CALACATTA ***
30,5X31



✕ **MOSAIC PRECIOUS MIX CALACATTA ***
35X35

✕ **LISTELO BRUSHED GOLD**
0,5X100

✕ **LISTELO BRUSHED SILVER**
0,5X100

✕ **LISTELO SHINE SILVER**
0,5X100

*
MOSAICO COM MISTURA DE PEÇAS BRILHO E MATE
MOSAIC MIXING GLOSSY AND MATT PIECES
MOSAÏQUE AVEC MÉLANGE DE PIÈCES FINITIONS BRILLANT ET MAT
MOSAİK MIT EINER MISCHUNG VON GLÄNZENDE UND MATT ELEMENTE

PEÇAS ESPECIAIS || SPECIAL PIECES || PIÈCES SPÉCIALES || SPEZIALTEILE || СПЕЦИАЛЬНЫЕ ЭЛЕМЕНТЫ

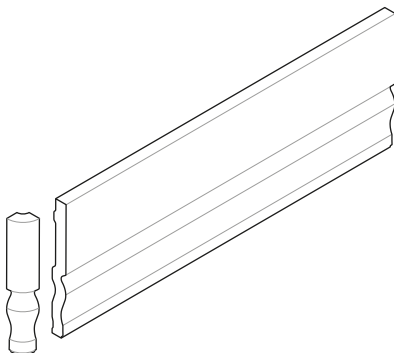

✕ **ALZATA PRECIOUS CALACATTA**
12,5X35
ANGOLO ALZATA PRECIOUS CALACATTA
12,5X2

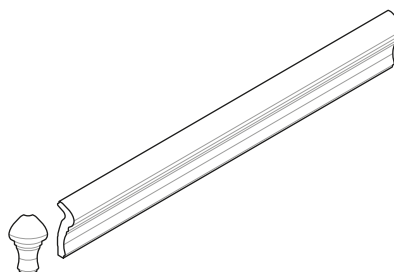

✕ **TORELLO PRECIOUS CALACATTA**
5X35
ANGOLO TORELLO PRECIOUS CALACATTA
5X2

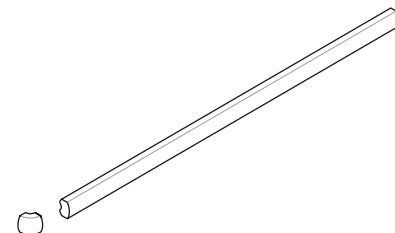

✕ **MATITA PRECIOUS CALACATTA**
1,5X35
ANGOLO MATITA PRECIOUS CALACATTA
1,5X2





Coleção
Collection
Kollektion
Коллекция

URBAN



REVESTIMENTO ESTRUTURADO COM ACABAMENTO MATE OU SEMI-BRILHO
MATT OR GLOSSY STRUCTURED WALL TILES
FAIÂNCES STRUCTURÉ EN FINITION MAT OU SEMI-BRILLANT
STRUKTURIERTE WANDFLIESEN - MATT ODER HALBMATT OBERFLÄCHE
НАСТЕННАЯ СТРУКТУРИРОВАННАЯ ПЛИТКА С МАТОВЫМ ИЛИ ПОЛУ-ГЛЯНЦЕВЫМ ПОКРЫТИЕМ



35x100  10,5mm

30x60  8,5mm

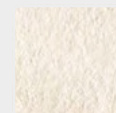

ROUGH WHITE

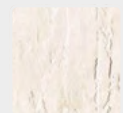

SLATE WHITE

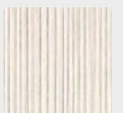

STRIPES WHITE

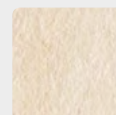

ROUGH BEIGE

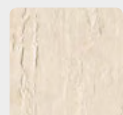

SLATE BEIGE

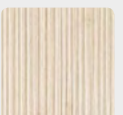

STRIPES BEIGE

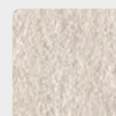

ROUGH GREY

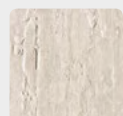

SLATE GREY

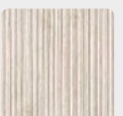

STRIPES GREY









URBAN









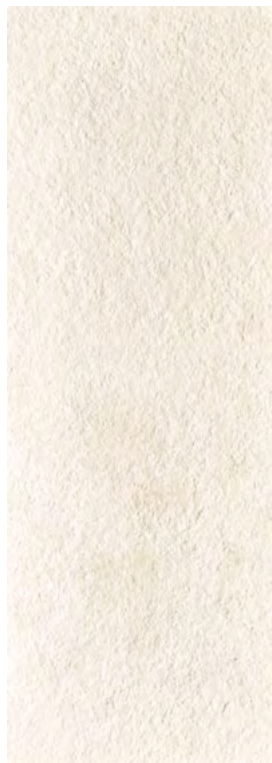

URBAN ROUGH WHITE
35X100 RET.



URBAN SLATE WHITE
35X100 RET.



URBAN STRIPES WHITE
35X100 RET.

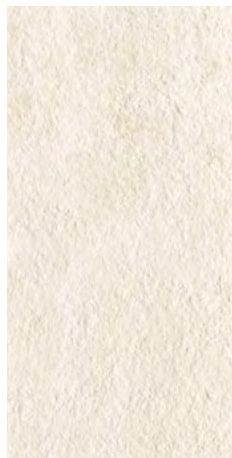

URBAN ROUGH WHITE
31X62
30X60 RET.



URBAN SLATE WHITE
31X62
30X60 RET.



URBAN STRIPES WHITE
31X62
30X60 RET.

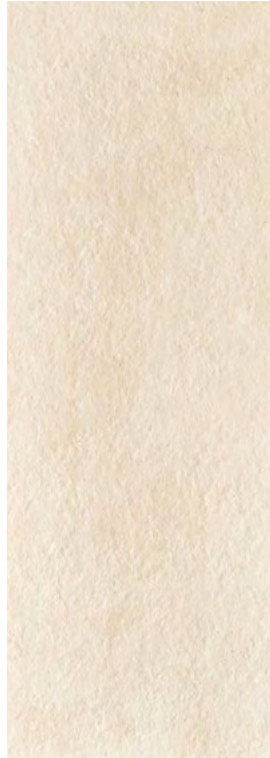

URBAN ROUGH BEIGE
35X100 RET.



URBAN SLATE BEIGE
35X100 RET.



URBAN STRIPES BEIGE
35X100 RET.

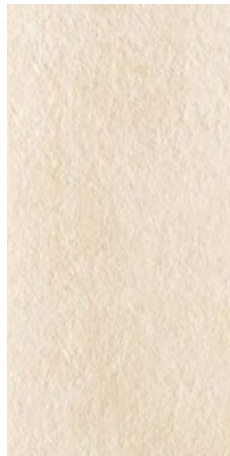

URBAN ROUGH BEIGE
31X62
30X60 RET.



URBAN SLATE BEIGE
31X62
30X60 RET.



URBAN STRIPES BEIGE
31X62
30X60 RET.



URBAN ROUGH GREY
35X100 RET.



URBAN SLATE GREY
35X100 RET.



URBAN STRIPES GREY
35X100 RET.



URBAN ROUGH GREY
31X62
30X60 RET.



URBAN SLATE GREY
31X62
30X60 RET.



URBAN STRIPES GREY
31X62
30X60 RET.



10,5mm
35X100
20X20

8,5mm
30X60
30X30



m²

TOWN WHITE *
35X100 RET.
30X60 RET.

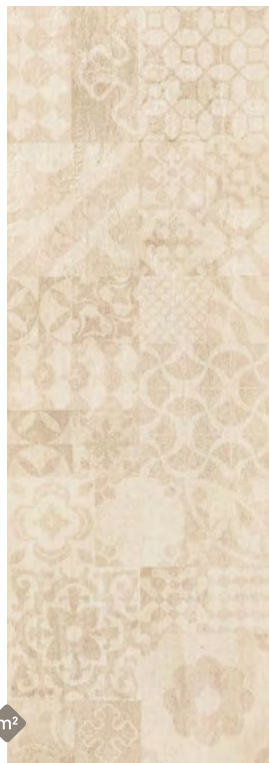

m²

TOWN BEIGE *
35X100 RET.
30X60 RET.



m²

TOWN GREY *
35X100 RET.
30X60 RET.



**LISTELO
BRUSHED GOLD**
0,5X100

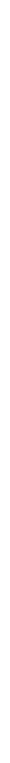

**LISTELO
BRUSHED SILVER**
0,5X100



**LISTELO
SHINE SILVER**
0,5X100

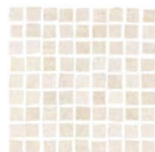

MOSAIC URBAN WHITE
20X20 (1,9X1,9)



MOSAIC URBAN BEIGE
20X20 (1,9X1,9)



MOSAIC URBAN GREY
20X20 (1,9X1,9)

* Os diferentes desenhos são embalados aleatoriamente.
The available patterns are packed randomly.
Les différents motifs sont emballés aléatoirement.
Die verschiedenen Grafiken sind aleatorisch eingepackt.



MOSAIC URBAN CITY WHITE
30X30 (3X3)



MOSAIC URBAN CITY BEIGE
30X30 (3X3)



MOSAIC URBAN CITY GREY
30X30 (3X3)

URBAN



URBAN



PAVIMENTOS COORDENADOS
 COORDINATED FLOOR TILES
 SOLS COORDONNÉS
 KOORDINIERTE BODEN FLIESEN
 КООРДИНИРОВАННАЯ НАПОЛЬНАЯ ПЛИТКА







Coleção
Collection
Kollektion
Коллекция

NEST



REREVESTIMENTO COM ACABAMENTO MATE OU SEMI-BRILHO
MATT OR SEMI-GLOSS WALL TILES
FAÏANCES EN FINITION MAT OU SEMI-BRILLANT
WANDFLIESEN - MATT ODER HALBMATT OBERFLÄCHE
НАСТЕННАЯ КЕРАМИЧЕСКАЯ ПЛИТКА С МАТОВЫМ ИЛИ ПОЛУ-ГЛЯНЦЕВЫМ ПОКРЫТИЕМ



35x100 

30x60 

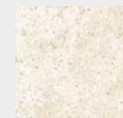

WHITE

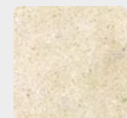

BEIGE

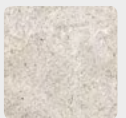

GREY

PAVIMENTO COM ACABAMENTO MATE OU SEMI-BRILHO
MATT OR GLOSSY FLOOR TILES
CARREAUX SOL EN FINITION MAT OU SEMI-BRILLANT
BODENFLIESEN - MATT ODER HALBMATT OBERFLÄCHE
НАПОЛЬНАЯ ПЛИТКА С МАТОВЫМ ИЛИ ПОЛУ-ГЛЯНЦЕВЫМ ПОКРЫТИЕМ



60x60 

30x60 

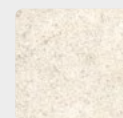

WHITE

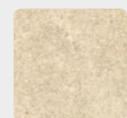

BEIGE

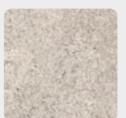

GREY

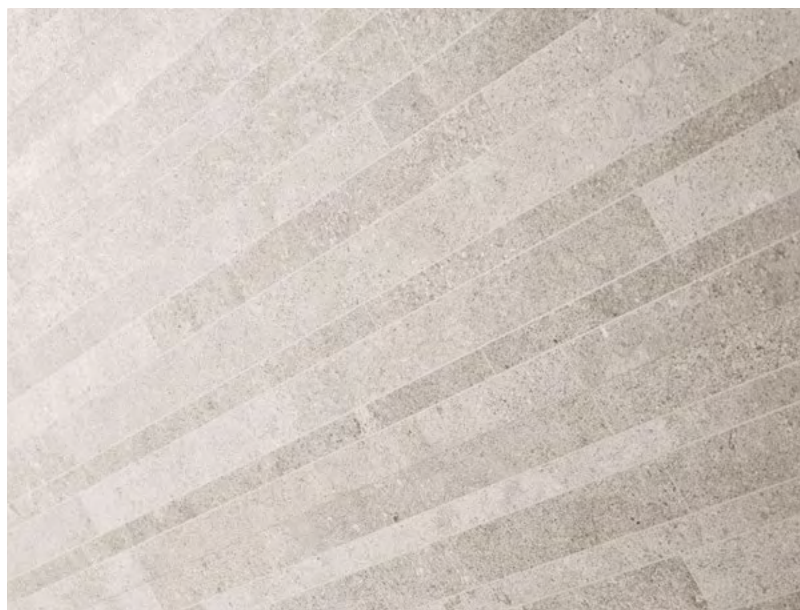





nest with me

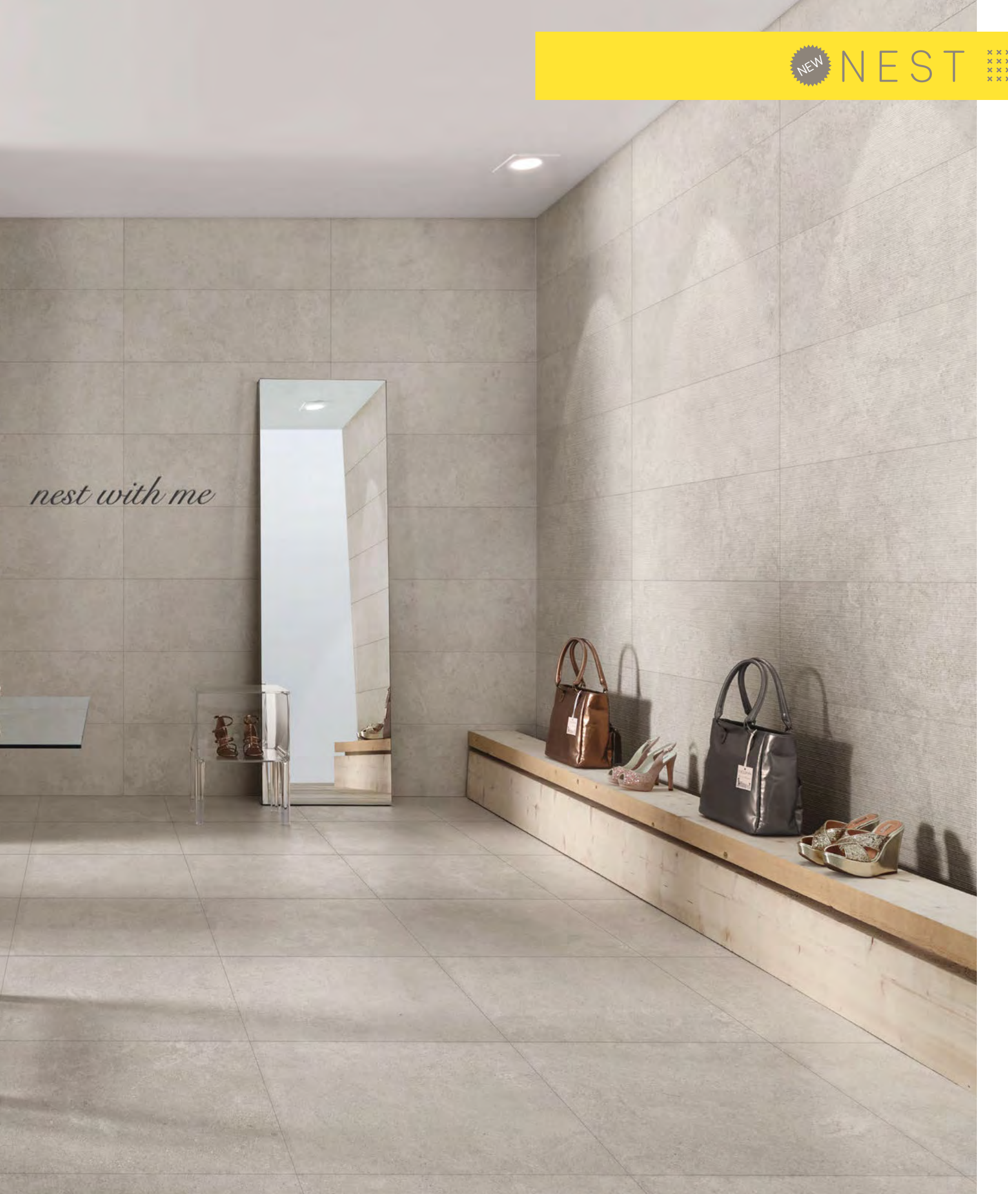









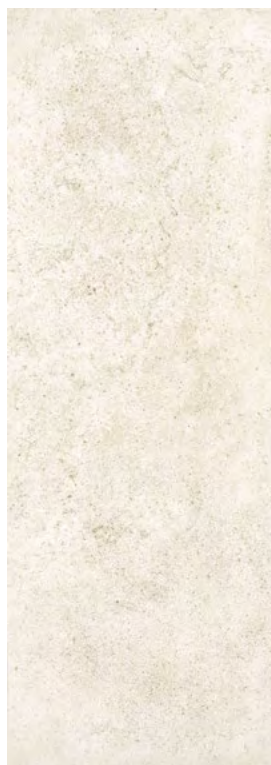

NEST WHITE
35X100 RET.
31X62
30X60 RET.



NEST BEIGE
35X100 RET.
31X62
30X60 RET.

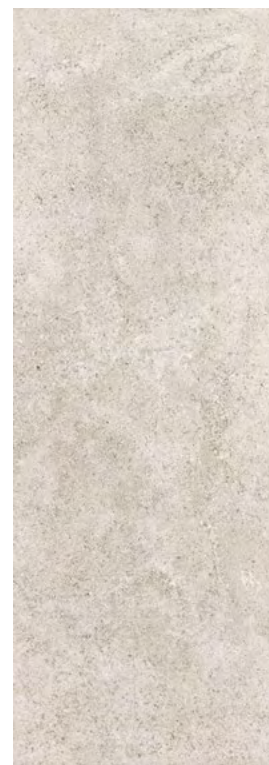

NEST GREY
35X100 RET.
31X62
30X60 RET.

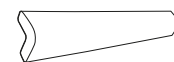

PERFIL NEST
1,7X50
1,7X35

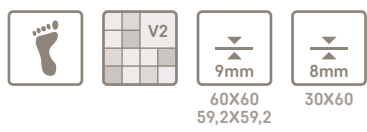

NEST WHITE
60X60
59,2X59,2 RET.
30X60



NEST BEIGE
60X60
59,2X59,2 RET.
30X60



NEST GREY
60X60
59,2X59,2 RET.
30X60

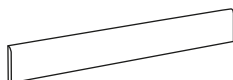

RODAPÉ NEST
8X60
8X59,2 RET.



TACO METAL BEIGE
10X10



TACO METAL GREY
10X10



11,3mm
10,5mm
RESTFUL

10,7mm
10,5mm
COMFY
35X100

8,7mm
8,5mm
COMFY
31X62
30X60



m²

COMFY NEST WHITE
35X100 RET.
31X62
30X60 RET.



m²

COMFY NEST BEIGE
35X100 RET.
31X62
30X60 RET.



m²

COMFY NEST GREY
35X100 RET.
31X62
30X60 RET.



m²

RESTFUL NEST WHITE
35X100 RET.



m²

RESTFUL NEST BEIGE
35X100 RET.

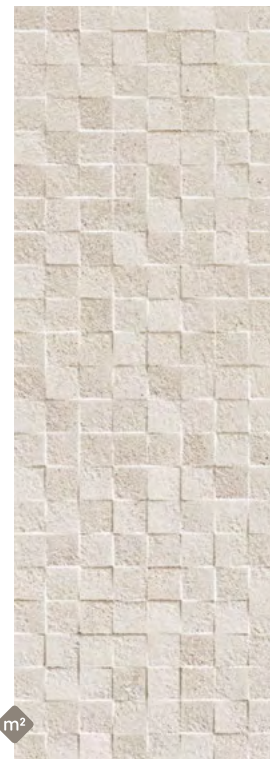

m²

RESTFUL NEST GREY
35X100 RET.

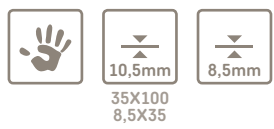

CARE WHITE
35X100 RET.



CARE BEIGE
35X100 RET.



CARE GREY
35X100 RET.

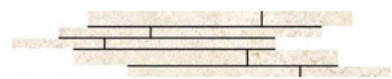

BRICK NEST WHITE
8,5X35



BRICK NEST BEIGE
8,5X35

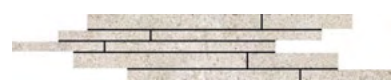

BRICK NEST GREY
8,5X35



LISTELO SNUG WHITE
6,5X62
6,5X60 RET.



LISTELO SNUG BEIGE
6,5X62
6,5X60 RET.



LISTELO SNUG GREY
6,5X62
6,5X60 RET.



COZY WHITE
31X62
30X60 RET.



COZY BEIGE
31X62
30X60 RET.



COZY GREY
31X62
30X60 RET.



BARRA NEST BEIGE
10X62



BARRA NEST GREY
10X62

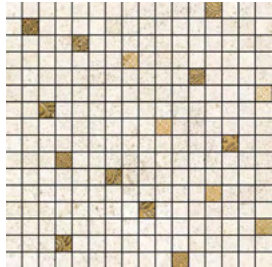

MOSAIC SHELTER WHITE
35X35 (1,9X1,9)

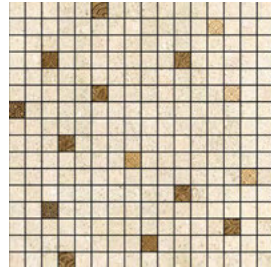

MOSAIC SHELTER BEIGE
35X35 (1,9X1,9)

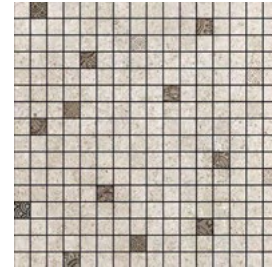

MOSAIC SHELTER GREY
35X35 (1,9X1,9)

LISTELO BRUSHED GOLD
0,5X100

LISTELO BRUSHED SILVER
0,5X100

LISTELO SHINE SILVER
0,5X100

BARRA INOX BRILHO
2X100

BARRA INOX BRILHO
1X100

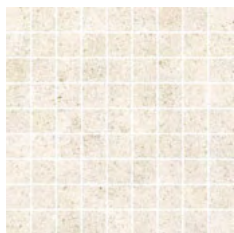

MOSAIC NEST WHITE
29,5X29,5 (3,1X3,1)



MOSAIC NEST BEIGE
29,5X29,5 (3,1X3,1)



MOSAIC NEST GREY
29,5X29,5 (3,1X3,1)





Coleção
Collection
Kollektion
Коллекция

AROMA



REVESTIMENTO COM ACABAMENTO BRILHO
GLOSSY WALL TILES
FAIANÇES AVEC FINITION BRILLANT
WANDFLIESEN - GLÄNZEND OBERFLÄCHE
НАСТЕННАЯ КЕРАМИЧЕСКАЯ ПЛИТКА С ГЛЯНЦЕВЫМ ПОКРЫТИЕМ



35x70



20x60

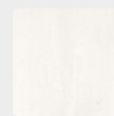

SALT

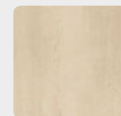

VANILLA

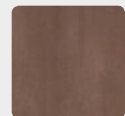

COFFEE

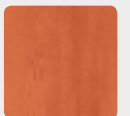

PAPAYA

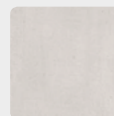

EARL GREY



OREGANO

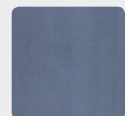

BLUEBERRY



BLACK PEPPER

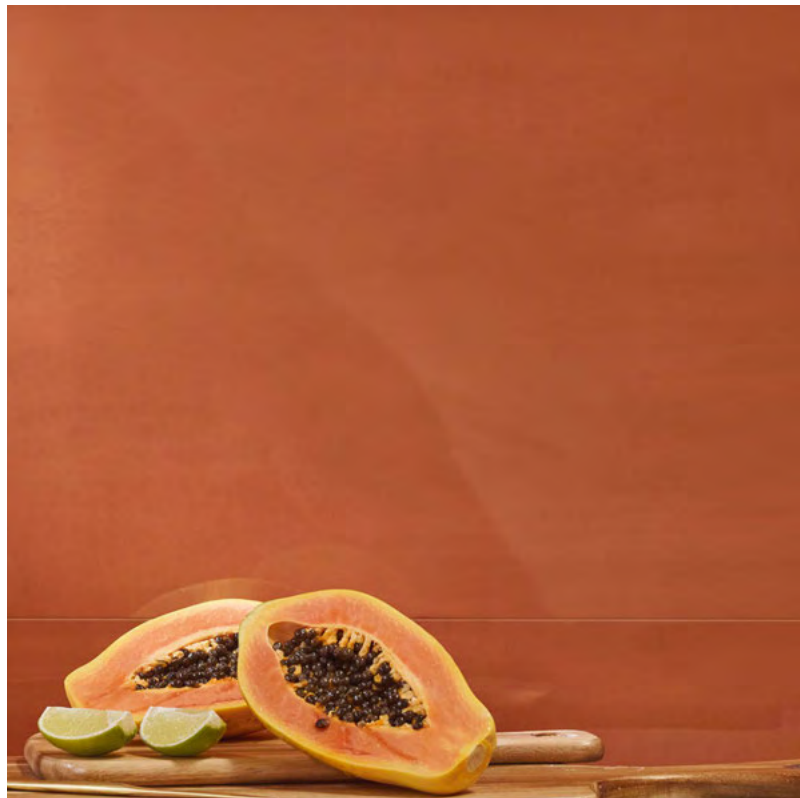

















MOSAIC SWEET BLUEBERRY 40x40



AROMA VANILLA 20x60 || AROMA COFFEE 20x60 || SUGARY 20x60

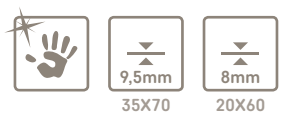

AROMA BLACK PEPPER
35X70 RET.



AROMA BLUEBERRY
35X70 RET.



AROMA OREGANO
35X70 RET.



AROMA EARL GREY
35X70 RET.

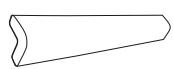

PERFIL AROMA
1,7X35

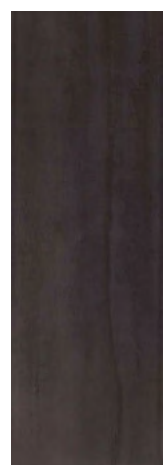

AROMA BLACK PEPPER
20X60



AROMA BLUEBERRY
20X60



AROMA OREGANO
20X60



AROMA EARL GREY
20X60



NEW AROMA



AROMA SALT
35X70 RET.

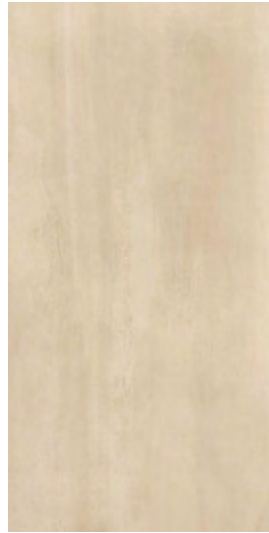

AROMA VANILLA
35X70 RET.



AROMA COFFEE
35X70 RET.



AROMA PAPAYA
35X70 RET.



AROMA SALT
20X60



AROMA VANILLA
20X60



AROMA COFFEE
20X60



AROMA PAPAYA
20X60

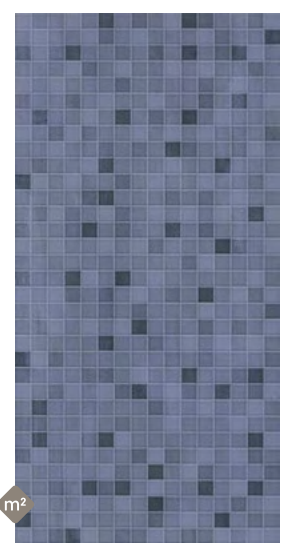
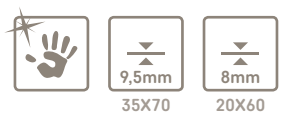

BLUEBERRY SEEDS
35X70 RET.



OREGANO SEEDS
35X70 RET.

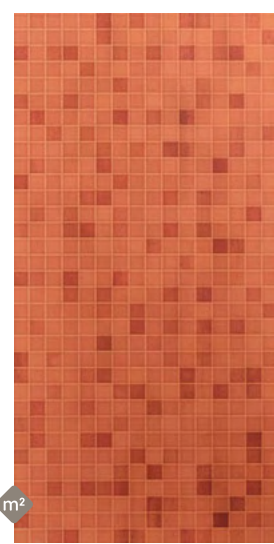

PAPAYA SEEDS
35X70 RET.



WINTER SEEDS
35X70 RET.



SUMMER SEEDS
35X70 RET.

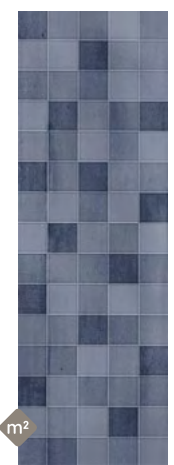

BLUEBERRY SEEDS
20X60

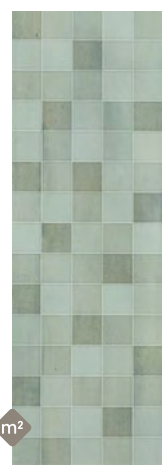

OREGANO SEEDS
20X60

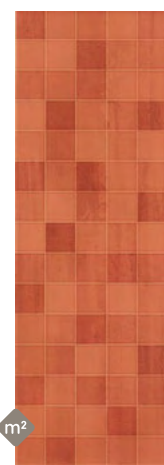

PAPAYA SEEDS
20X60



WINTER SEEDS
20X60



SUMMER SEEDS
20X60



OREGANO POWDER
35X70 RET.



SALT POWDER
35X70 RET.



VANILLA POWDER
35X70 RET.



COFFEE POWDER
35X70 RET.



OREGANO PLEASANT
20X60

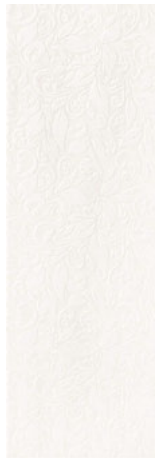

SALT PLEASANT
20X60

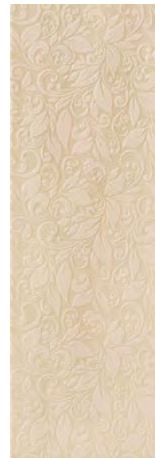

VANILLA PLEASANT
20X60



COFFEE PLEASANT
20X60

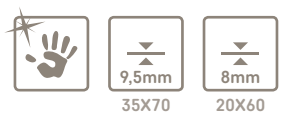

m²

ORIENTAL EARL GREY
35X70 RET.



m²

ORIENTAL VANILLA
35X70 RET.



m²

ORIENTAL DARK VANILLA
35X70 RET.



SCENT SALT
35X70 RET.



m²

ORIENTAL EARL GREY
20X60

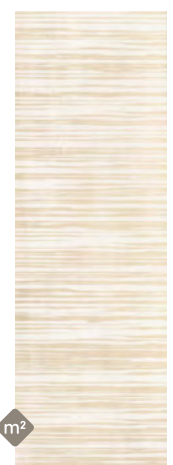

m²

ORIENTAL VANILLA
20X60

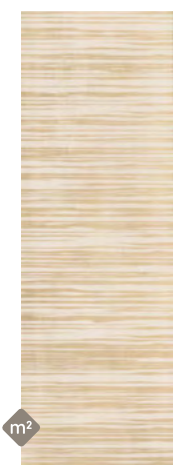

m²

ORIENTAL DARK VANILLA
20X60



m²
SEA SALT
35X70 RET.



BLUEBERRY BOUQUET
35X70 RET.

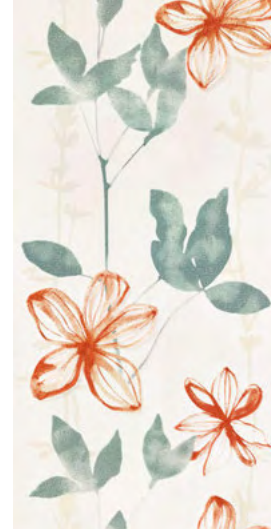

OREGANO BOUQUET
35X70 RET.



m²
MIX SPICES
35X70 RET.



m²



m²



Peça com 11 gráficas diferentes embalada aleatoriamente em embalagens de 5 peças.
Pieces of 11 different patterns randomly packed in boxes of 5 pieces.
Pièces avec 11 dessins différents emballés aléatoirement em groupe de 5.
Stücke in 11 verschiedenen Grafik-Design-Muster aleatorisch eingepackt.



AROMA

NEW



RANDOM ART



m²

**BLACK PEPPER
FLAVOUR**
20X60

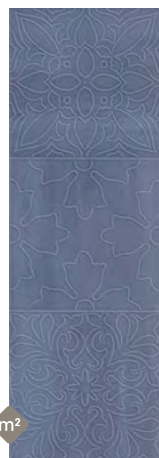

m²

**BLUEBERRY
FLAVOUR**
20X60



m²

OREGANO FLAVOUR
20X60



m²

**EARL GREY
FLAVOUR**
20X60



m²

SALT FLAVOUR
20X60

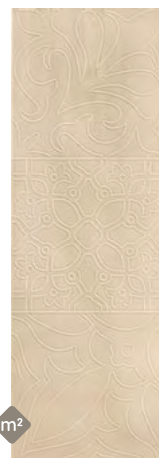

m²

VANILLA FLAVOUR
20X60

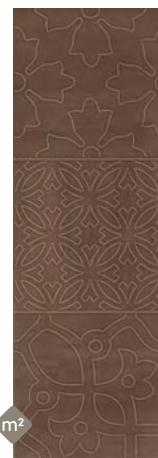

m²

COFFEE FLAVOUR
20X60



m²

PAPAYA FLAVOUR
20X60

Os diferentes desenhos são embalados aleatoriamente.
The available patterns are packed randomly.
Les différents motifs sont emballés aléatoirement.
Die verschiedenen Grafiken sind aleatorisch eingepackt.



DELICIOUS COLD
20X60

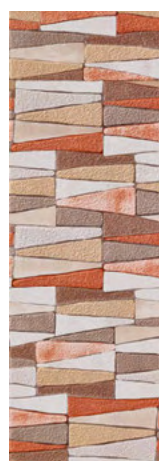

DELICIOUS WARM
20X60



SALTY
20X60



SUGARY
20X60



FROSTY BLACK PEPPER
20X60

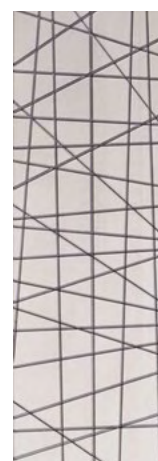

FROSTY EARL GREY
20X60

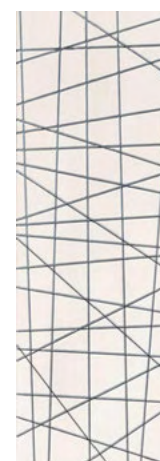

FROSTY SALT
20X60

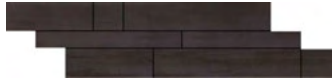

BRICKS AROMA BLACK PEPPER
10X34



BRICKS AROMA EARL GREY
10X34



BRICKS AROMA SALT
10X34



BRICKS AROMA COFFEE
10X34



BRICKS AROMA VANILLA
10X34

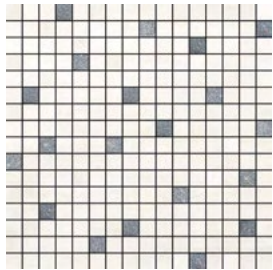

MOSAIC AROMA COLD
35X35 (2X2)

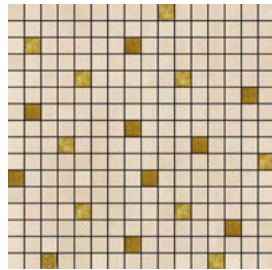

MOSAIC AROMA WARM
35X35 (2X2)



MOSAIC HEXAGON AROMA SALT
30X30



BARRA YUMMI VANILLA
6,5X70

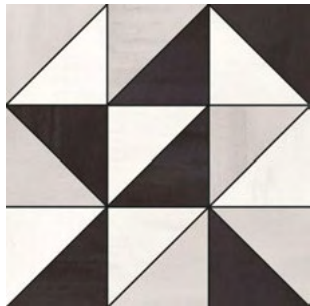

MOSAIC SWEET BLACK PEPPER
40X40

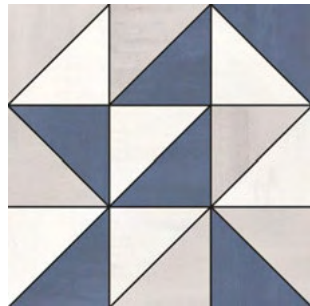

MOSAIC SWEET BLUEBERRY
40X40

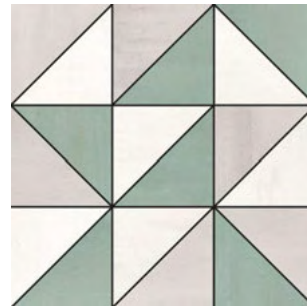

MOSAIC SWEET OREGANO
40X40

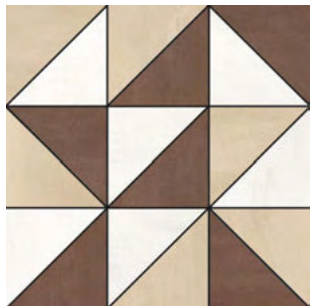

MOSAIC SWEET COFFEE
40X40

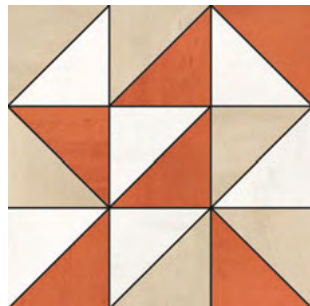

MOSAIC SWEET PAPAYA
40X40



BARRA AROMA COFFEE
6,5X60



BARRA AROMA BLACK PEPPER
6,5X60



PAVIMENTOS COORDENADOS
 COORDINATED FLOOR TILES
 SOLS COORDONNÉS
 KOORDINIERTE BODEN FLIESEN
 КООРДИНИРОВАННАЯ НАПОЛЬНАЯ ПЛИТКА



AROMA
 BLACK PEPPER



AROMA
 BLUEBERRY



AROMA
 OREGANO



AROMA
 EARL GREY





PAVIMENTOS COORDENADOS
 COORDINATED FLOOR TILES
 SOLS COORDONNÉS
 KOORDINIERTE BODEN FLIESEN
 КООРДИНИРОВАННАЯ НАПОЛЬНАЯ ПЛИТКА



WILDWOOD TORTORA

WILDWOOD LIGHT GREY

WILDWOOD GREY

FUSION TORTORA

FUSION GREY

GROUND WHITE

GROUND LIGHT GREY

GROUND GREY



PLACE WHITE

BLEND WHITE

BLEND LIGHT GREY

BLEND GREY

BLEND DARK GREY

BLEND GREEN

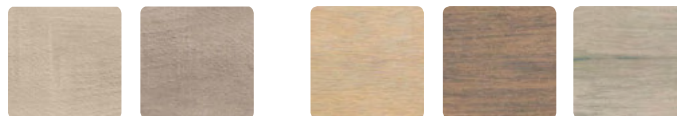

WILDWOOD BEIGE

WILDWOOD TORTORA

FUSION BEIGE

FUSION BROWN

FUSION TORTORA

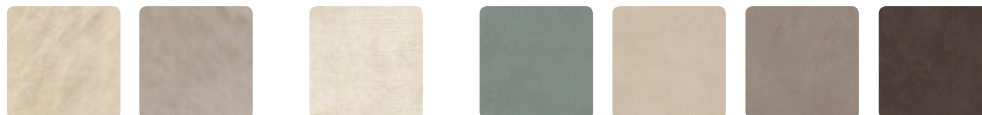

GROUND CREAM

GROUND TORTORA

PLACE WHITE

BLEND GREEN

BLEND BEIGE

BLEND TORTORA

BLEND BROWN

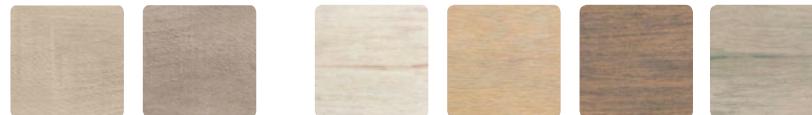

WILDWOOD BEIGE

WILDWOOD TORTORA

FUSION WHITE

FUSION BEIGE

FUSION BROWN

FUSION TORTORA



PLACE WHITE

PLACE TORTORA

BLEND WHITE

BLEND BEIGE

BLEND TORTORA

BLEND BROWN

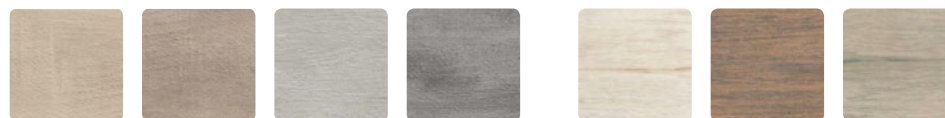

WILDWOOD BEIGE

WILDWOOD TORTORA

WILDWOOD LIGHT GREY

WILDWOOD GREY

FUSION WHITE

FUSION BROWN

FUSION TORTORA



GROUND TORTORA

GROUND GREY

BLEND WHITE

BLEND BEIGE

BLEND TORTORA

BLEND BROWN



AROMA SALT

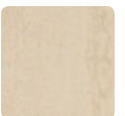

AROMA VANILLA

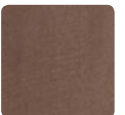

AROMA COFFEE



AROMA PAPAYA





Coleção
Collection
Kollektion
Коллекция

BLEND



PAVIMENTO COM ACABAMENTO MATE OU SEMI-BRILHO
MATT OR GLOSSY FLOOR TILES
CARREAUX SOL EN FINITION MAT OU SEMI-BRILLANT.
BODENFLIESEN - MATT ODER HALBMATT OBERFLÄCHE
НАПОЛЬНАЯ ПЛИТКА С МАТОВЫМ ИЛИ ПОЛУ-ГЛЯНЦЕВЫМ ПОКРЫТИЕМ



50x50

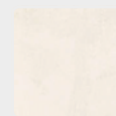

WHITE

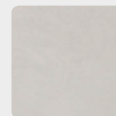

LIGHT GREY

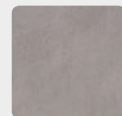

GREY



DARK GREY

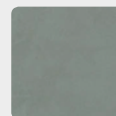

GREEN

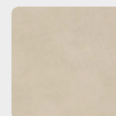

BEIGE

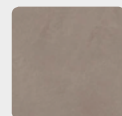

TORTORA

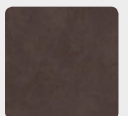

BROWN

BLEND 



NEW

BLEND



BLEND WHITE
51X51
50X50 RET.



BLEND LIGHT GREY
51X51
50X50 RET.



BLEND GREY
51X51
50X50 RET.



BLEND DARK GREY
51X51
50X50 RET.

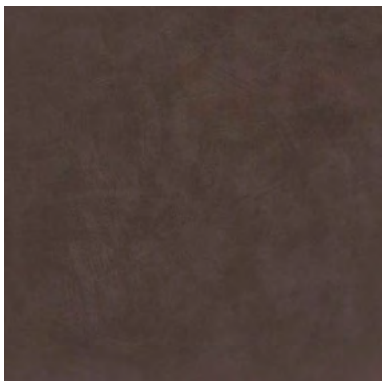

BLEND BROWN
51X51
50X50 RET.

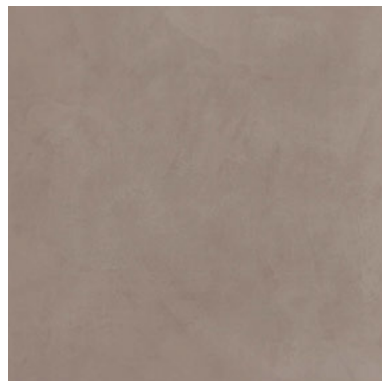

BLEND TORTORA
51X51
50X50 RET.



BLEND BEIGE
51X51
50X50 RET.



BLEND GREEN
51X51
50X50 RET.



TIRA BLEND BROWN
5X50



TIRA BLEND TORTORA
5X50



TIRA BLEND BEIGE
5X50

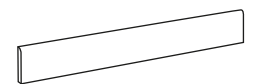

RODAPÉ BLEND
8X50
8X51



TACO BLEND BROWN
5X5



TACO BLEND TORTORA
5X5



TACO BLEND BEIGE
5X5

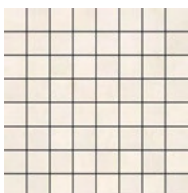

MOSAIC BLEND WHITE
24,9X24,9 (2,9X2,9)

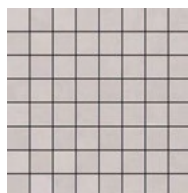

MOSAIC BLEND LIGHT GREY
24,9X24,9 (2,9X2,9)

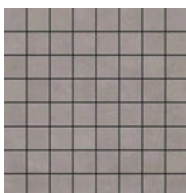

MOSAIC BLEND GREY
24,9X24,9 (2,9X2,9)

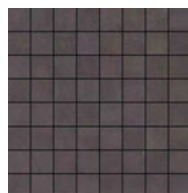

MOSAIC BLEND DARK GREY
24,9X24,9 (2,9X2,9)



MOSAIC BLEND BROWN
24,9X24,9 (2,9X2,9)

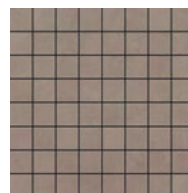

MOSAIC BLEND TORTORA
24,9X24,9 (2,9X2,9)

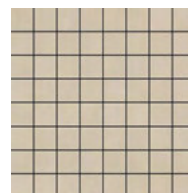

MOSAIC BLEND BEIGE
24,9X24,9 (2,9X2,9)

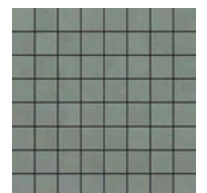

MOSAIC BLEND GREEN
24,9X24,9 (2,9X2,9)



ACQUA



REVESTIMENTO COM ACABAMENTO BRILHO
GLOSSY WALL TILES
FAÏANCES AVEC FINITION BRILLANT
WANDFLIESEN - GLÄNZEND OBERFLÄCHE
НАСТЕННАЯ КЕРАМИЧЕСКАЯ ПЛИТКА С ГЛЯНЦЕВЫМ ПОКРЫТИЕМ



35x100  10,5mm

22x45  7,5mm

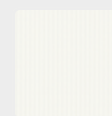

BIANCO

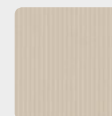

BEIGE

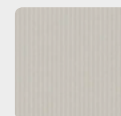

GRIGIO

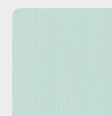

TURCHESE



RUBI

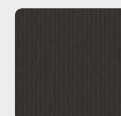

NERO

30x60  8,5mm

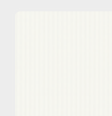

BIANCO

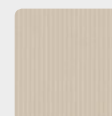

BEIGE

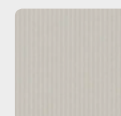

GRIGIO

XXXX
XXXX
XXXX
XXXX
ACQUA





XXXX
XXXX
XXXX
XXXX
ACQUA









XXXX
XXXX
XXXX
XXXX
ACQUA







ACQUA BIANCO 31X62 || ACQUA BEIGE 31X62 || FIUME BIANCO 31X62



ACQUA BIANCO 22,5X45 || ACQUA NERO 22,5X45 || VELA NERO 22,5X45





ACQUA BIANCO
35X100 RET.
31X62
22,5X45



ACQUA BEIGE
35X100 RET.
31X62
22,5X45

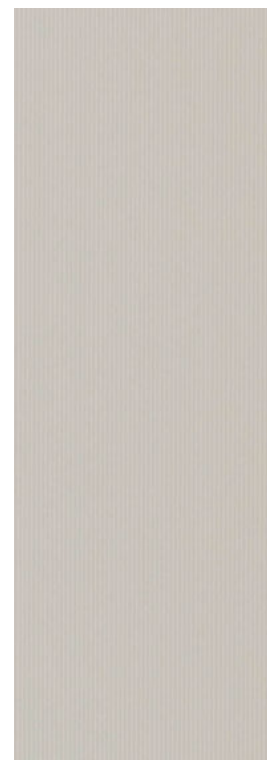

ACQUA GRIGIO
35X100 RET.
31X62
22,5X45



ACQUA TURCHESE
35X100 RET.
22,5X45



ACQUA RUBI
35X100 RET.
22,5X45



ACQUA NERO
35X100 RET.
22,5X45



PERFIL ACQUA
1,7X50
1,7X35

ACQUA



FIUME BIANCO
35X100 RET.
31X62



m²

LAGO
35X100 RET.
31X62
22,5X45



m²

LAGUNA
35X100 RET.
31X62
22,5X45

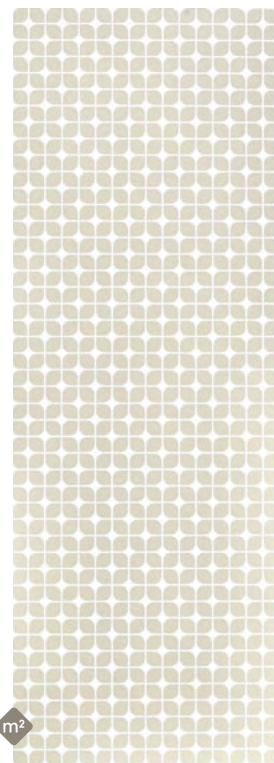

m²

CANALE GRIGIO
35X100 RET.
22,5X45



m²

CANALE BEIGE
35X100 RET.
22,5X45



BARRA FIUME BIANCO
5X35

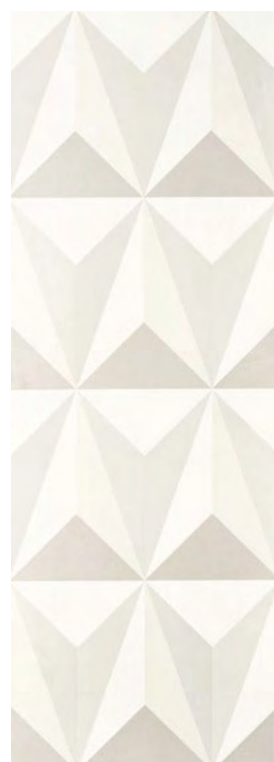

NEVE
35X100 RET.



CASCATA TURCHESE
35X100 RET.



CASCATA RUBI
35X100 RET.

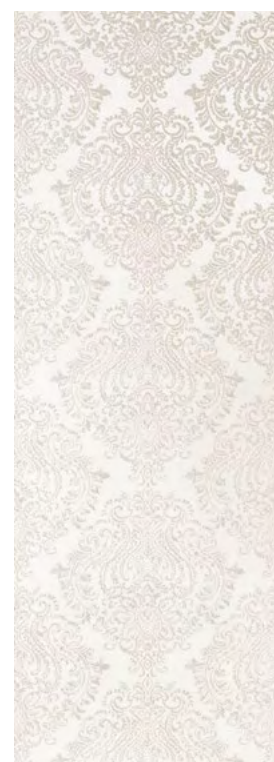

ARIA
35X100 RET.

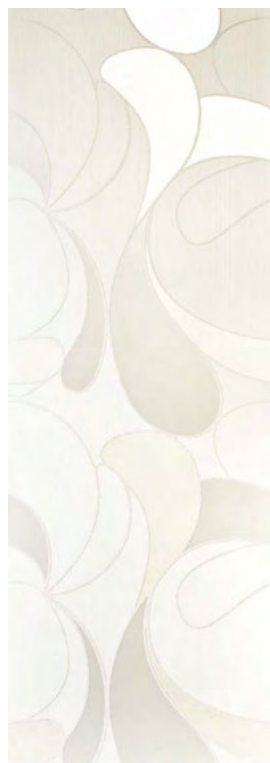

LACRIMA BIANCO
35X100 RET.

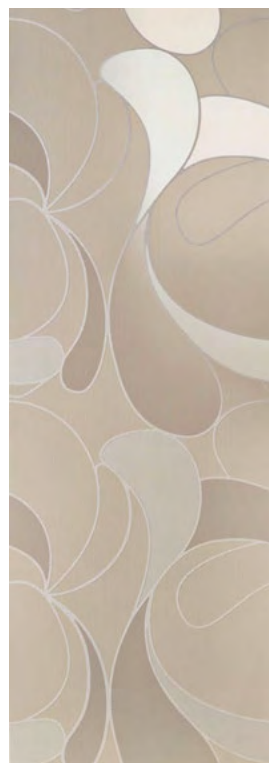

LACRIMA BEIGE
35X100 RET.

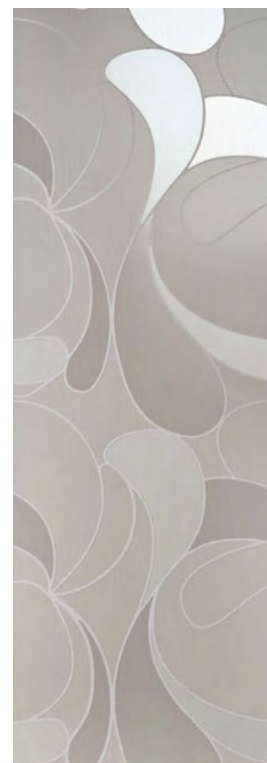

LACRIMA GRIGIO
35X100 RET.

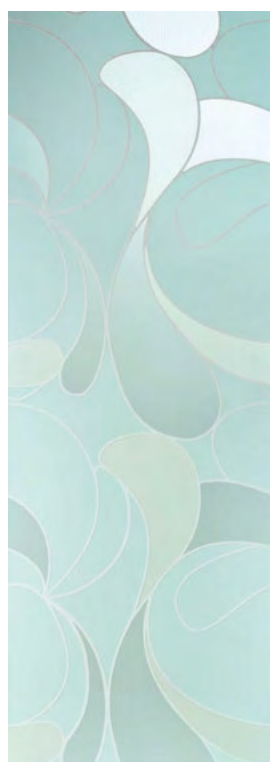

LACRIMA TURCHESE
35X100 RET.

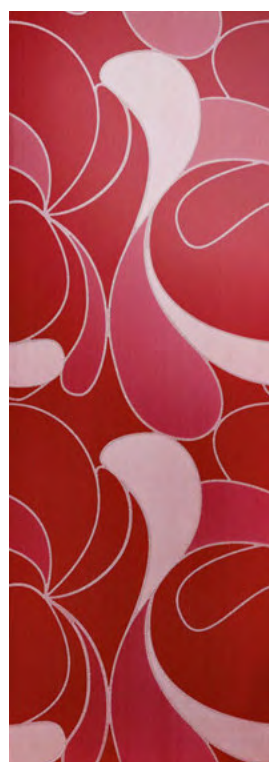

LACRIMA RUBI
35X100 RET.

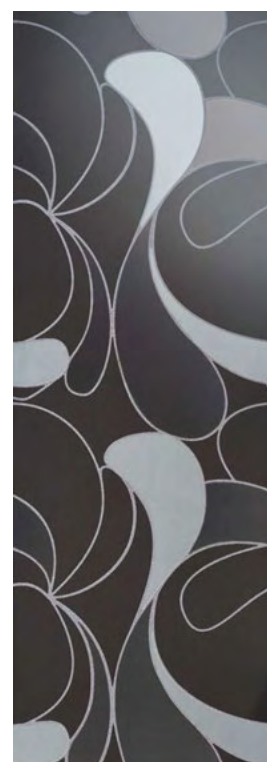

LACRIMA NERO
35X100 RET.

ACQUA

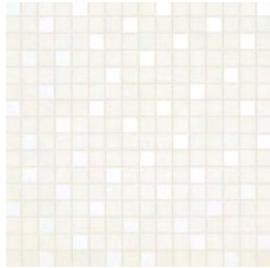

MOSAIC ACQUA BIANCO
35X35 (1,9X1,9)

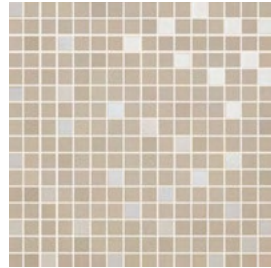

MOSAIC ACQUA BEIGE
35X35 (1,9X1,9)

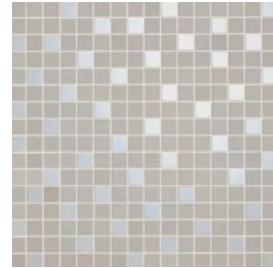

MOSAIC ACQUA GRIGIO
35X35 (1,9X1,9)

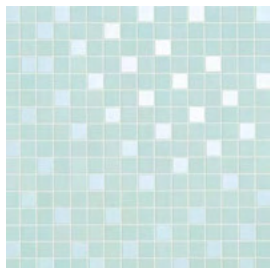

MOSAIC ACQUA TURCHESE
35X35 (1,9X1,9)

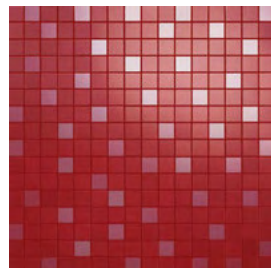

MOSAIC ACQUA RUBI
35X35 (1,9X1,9)

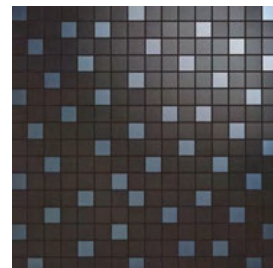

MOSAIC ACQUA NERO
35X35 (1,9X1,9)

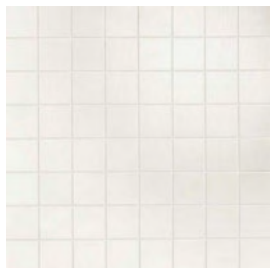

MOSAIC OCEANO BIANCO
35X35 (4X4)

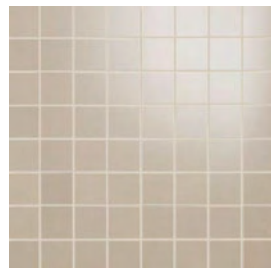

MOSAIC OCEANO BEIGE
35X35 (4X4)

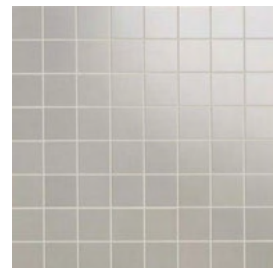

MOSAIC OCEANO GRIGIO
35X35 (4X4)

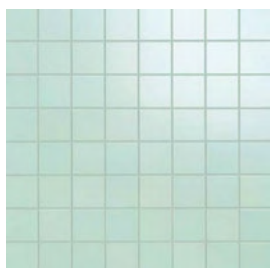

MOSAIC OCEANO TURCHESE
35X35 (4X4)

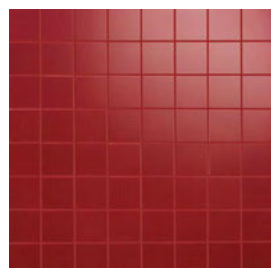

MOSAIC OCEANO RUBI
35X35 (4X4)

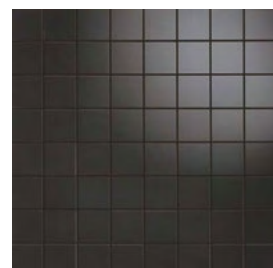

MOSAIC OCEANO NERO
35X35 (4X4)

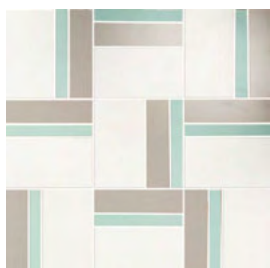

MOSAIC DILUVIO TURCHESE
35X35

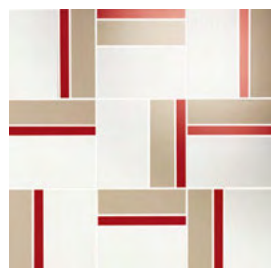

MOSAIC DILUVIO RUBI
35X35



BARRA ALVEO BIANCO
8,2X100 (1,9X100)

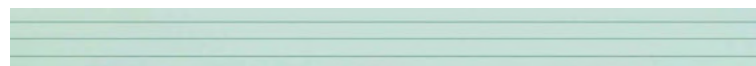

BARRA ALVEO TURCHESE
8,2X100 (1,9X100)



BARRA ALVEO BEIGE
8,2X100 (1,9X100)

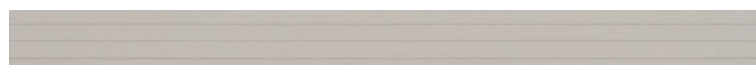

BARRA ALVEO GRIGIO
8,2X100 (1,9X100)

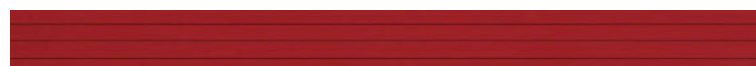

BARRA ALVEO RUBI
8,2X100 (1,9X100)

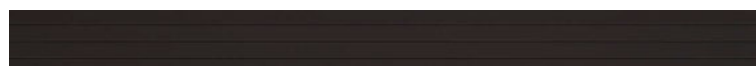

BARRA ALVEO NERO
8,2X100 (1,9X100)



BARRA INOX BRILHO
2X100



BARRA INOX BRILHO
1X100

ACQUA



ONDA BIANCO
31X62



ONDA BEIGE
31X62



ONDA GRIGIO
31X62



FIUME BIANCO
31X62



BARRA FIUME BIANCO
5X62



BARRA STRETTO
5X22,5

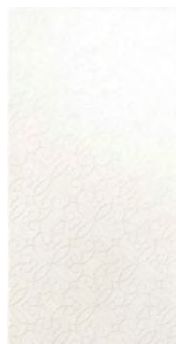

NUBE BIANCO
22,5X45

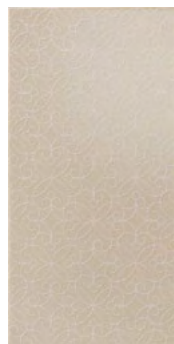

NUBE BEIGE
22,5X45

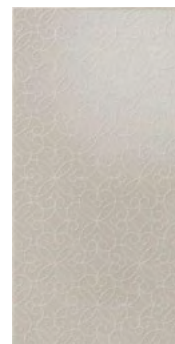

NUBE GRIGIO
22,5X45



MARE TURCHESE
22,5X45



MARE RUBI
22,5X45



BARRA MARE TURCHESE
5X45



BARRA MARE RUBI
5X45



BARRA COSTA TURCHESE
5X45



BARRA COSTA RUBI
5X45



BARRA RIVIERA TURCHESE
5X45



BARRA RIVIERA RUBI
5X45



VELA TURCHESE
22,5X45

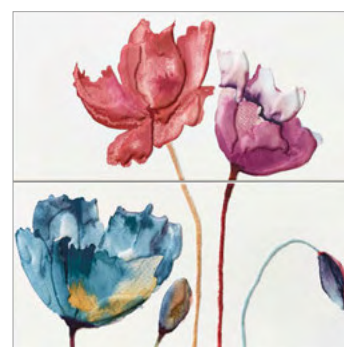

FIORI DI CORALLO
45X45



VELA NERO
22,5X45

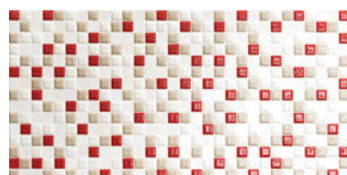

VELA RUBI
22,5X45

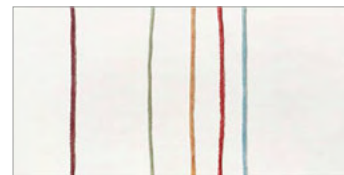

CORALLO
22,5X45

ACQUA



PAVIMENTOS COORDENADOS
 COORDINATED FLOOR TILES
 SOLS COORDONNÉS
 KOORDINIERTE BODEN FLIESEN
 КООРДИНИРОВАННАЯ НАПОЛЬНАЯ ПЛИТКА



ACQUA BIANCO



ACQUA BEIGE



ACQUA GRIGIO





PAVIMENTOS COORDENADOS
 COORDINATED FLOOR TILES
 SOLS COORDONNÉS
 KOORDINIERTE BODEN FLIESEN
 КООРДИНИРОВАННАЯ НАПОЛЬНАЯ ПЛИТКА



 ACQUA
 TURCHESE



 ACQUA
 RUBI



 ACQUA
 NERO



Coleção
Collection
Kollektion
Коллекция

PARFUM



REVESTIMENTO COM ACABAMENTO BRILHO
GLOSSY WALL TILES
FAÏANCES AVEC FINITION BRILLANT
WANDFLIESEN - GLÄNZEND OBERFLÄCHE
НАСТЕННАЯ КЕРАМИЧЕСКАЯ ПЛИТКА С ГЛЯНЦЕВЫМ ПОКРЫТИЕМ



35x100  12mm

22x45  9mm



JASMIN BLANC

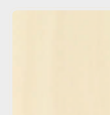

VANILLE

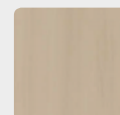

CANNELLE



AMBRE GRIS



LYS BLEU

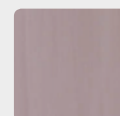

LAVANDE

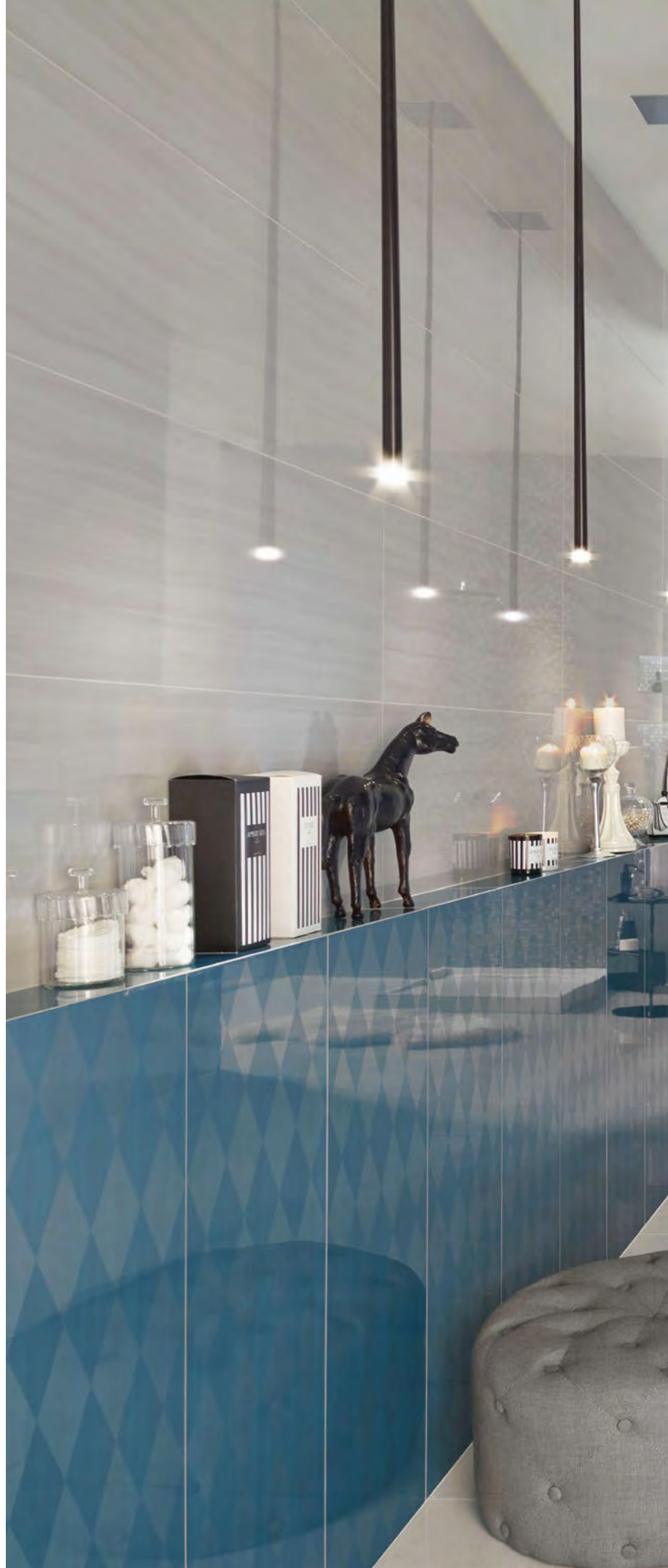
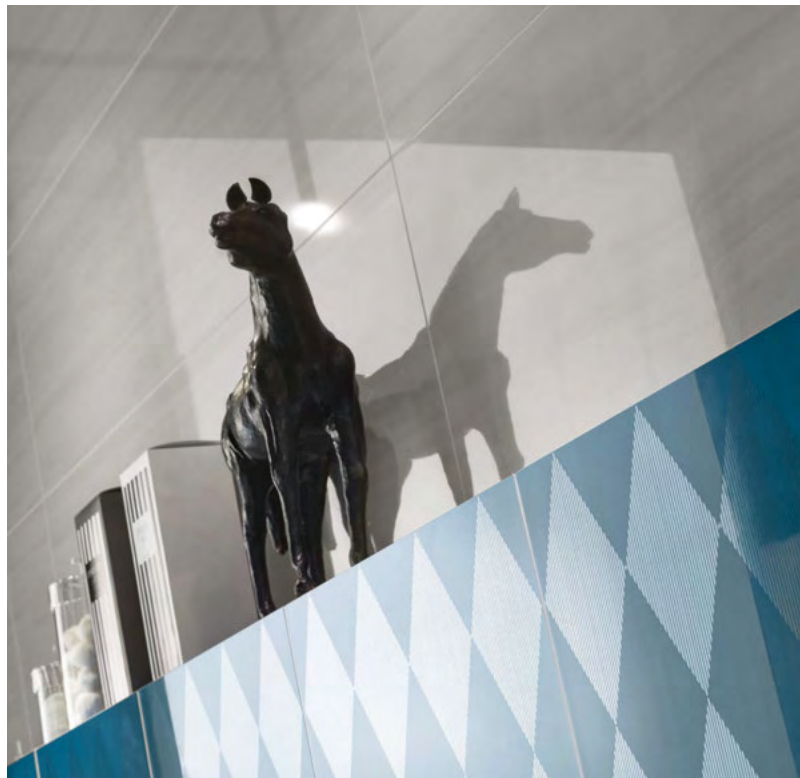



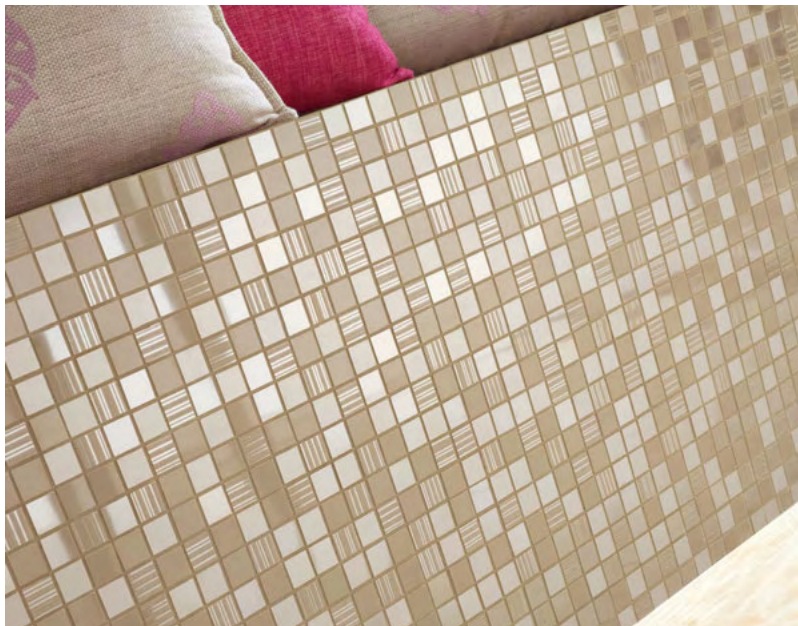











PARFUM VANILLE 22,5X45 || PARFUM LAVANDE 22,5X45 || BARRA ÉVIDENCE LAVANDE 5X45 || BARRA FRAGRANCE LAVANDE 5X45



PARFUM JASMIN BLANC
35X100 RET.
22,5X45



PARFUM VANILLE
35X100 RET.
22,5X45



PARFUM CANNELLE
35X100 RET.
22,5X45



PARFUM AMBRE GRIS
35X100 RET.
22,5X45



PARFUM LYS BLEU
35X100 RET.
22,5X45

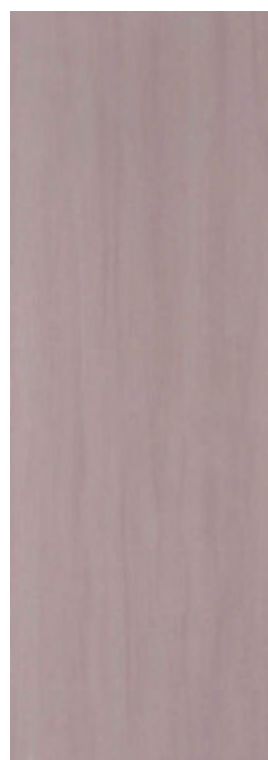

PARFUM LAVANDE
35X100 RET.
22,5X45



PERFIL PARFUM
1,7X50
1,7X35



POISON VANILLE
35X100 RET.



POISON CANNELLE
35X100 RET.



POISON LAVANDE
35X100 RET.

Com aplicação de Swarovski · with swarovski (crystal) inserts · avec application (de cristaux) Swarovski
mit Swarovski Kristall Anwendung · Со вставками из страз Swarovski



MISS CANNELLE
35X100 RET.



MISS AMBRE GRIS
35X100 RET.

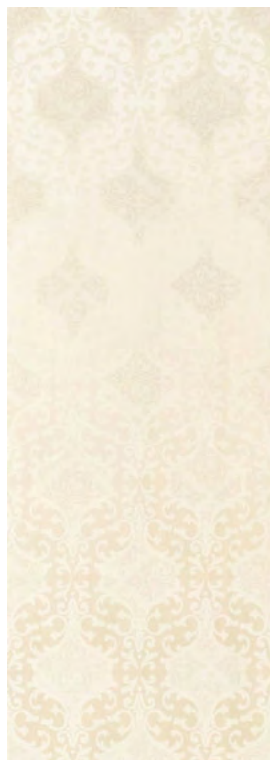

PURE POISON JASMIN BLANC
35X100 RET.



STOCK OFF BARRA MADEMOISELLE
JASMIN BLANC
5,7X35



PURE POISON VANILLE
35X100 RET.



STOCK OFF BARRA MADEMOISELLE
VANILLE
5,7X35



PURE POISON CANNELLE
35X100 RET.



STOCK OFF BARRA MADEMOISELLE
CANNELLE
5,7X35



PURE POISON AMBRE GRIS
35X100 RET.



STOCK OFF BARRA MADEMOISELLE
AMBRE GRIS
5,7X35



PURE POISON LYS BLEU
35X100 RET.



STOCK OFF BARRA MADEMOISELLE
LYS BLEU
5,7X35



PURE POISON LAVANDE
35X100 RET.



STOCK OFF BARRA MADEMOISELLE
LAVANDE
5,7X35



GLAMOUR JASMIN BLANC
35X100 RET.

LISTELO ALLURE
JASMIN BLANC
2X35
STOCK OFF



GLAMOUR VANILLE
35X100 RET.

LISTELO ALLURE
VANILLE
2X35
STOCK OFF



GLAMOUR CANNELLE
35X100 RET.

LISTELO ALLURE
CANNELLE
2X35
STOCK OFF



GLAMOUR AMBRE GRIS
35X100 RET.

LISTELO ALLURE
AMBRE GRIS
2X35
STOCK OFF

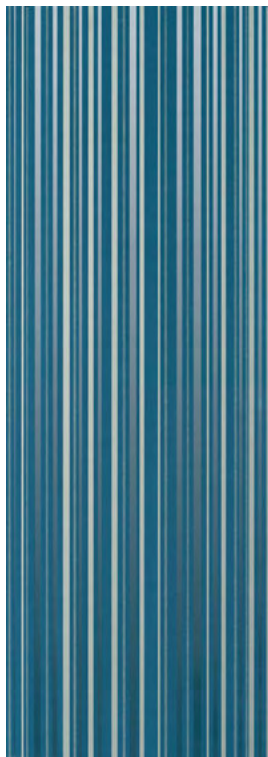

GLAMOUR LYS BLEU
35X100 RET.

LISTELO ALLURE
LYS BLEU
2X35
STOCK OFF



GLAMOUR LAVANDE
35X100 RET.

LISTELO ALLURE
LAVANDE
2X35
STOCK OFF



OBSSESSION JASMIN BLANC
35X100 RET.



OBSSESSION VANILLE
35X100 RET.



OBSSESSION CANNELLE
35X100 RET.



OBSSESSION AMBRE GRIS
35X100 RET.



OBSSESSION LYS BLEU
35X100 RET.



OBSSESSION LAVANDE
35X100 RET.



J'ADORE JASMIN BLANC
35X100 RET.



J'ADORE VANILLE
35X100 RET.



J'ADORE CANNELLE
35X100 RET.



J'ADORE AMBRE GRIS
35X100 RET.



J'ADORE LYS BLEU
35X100 RET.



J'ADORE LAVANDE
35X100 RET.

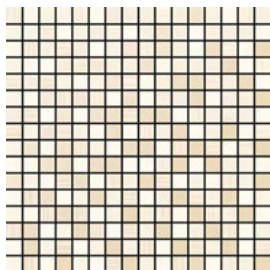

MOSAIC TRÉSOR
JASMIN BLANC
35X35 (1,9X1,9)

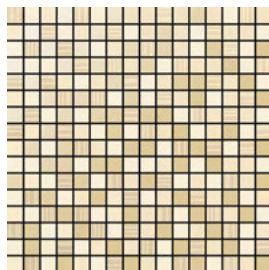

MOSAIC TRÉSOR
VANILLE
35X35 (1,9X1,9)

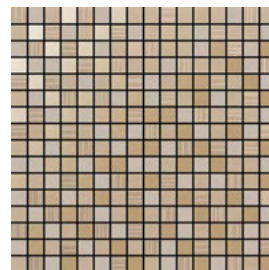

MOSAIC TRÉSOR
CANNELLE
35X35 (1,9X1,9)

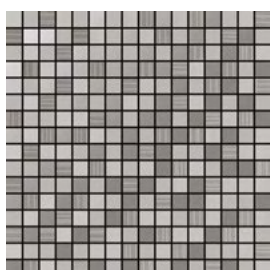

MOSAIC TRÉSOR
AMBRE GRIS
35X35 (1,9X1,9)

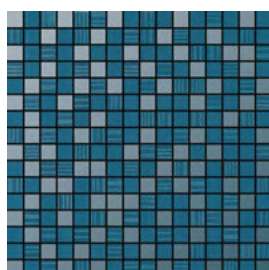

MOSAIC TRÉSOR
LYS BLEU
35X35 (1,9X1,9)

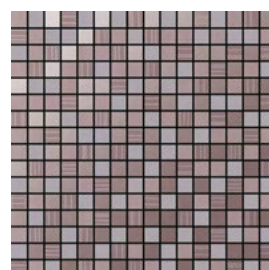

MOSAIC TRÉSOR
LAVANDE
35X35 (1,9X1,9)

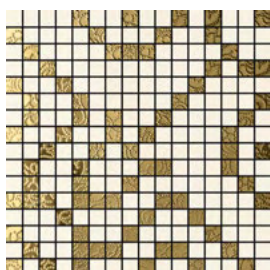

MOSAIC INSOLENC
JASMIN BLANC
35X35 (2X2)

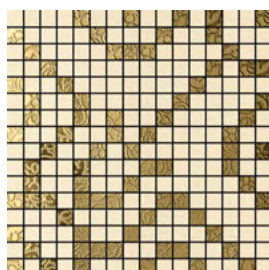

MOSAIC INSOLENC
VANILLE
35X35 (2X2)

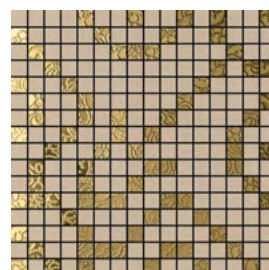

MOSAIC INSOLENC
CANNELLE
35X35 (2X2)

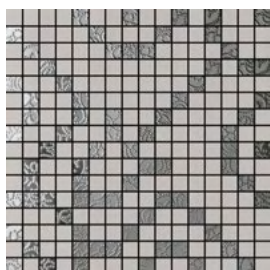

MOSAIC INSOLENC
AMBRE GRIS
35X35 (2X2)

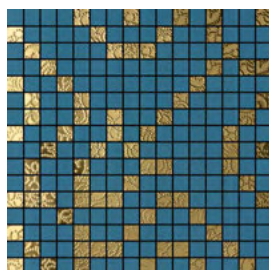

MOSAIC INSOLENC
LYS BLEU
35X35 (2X2)

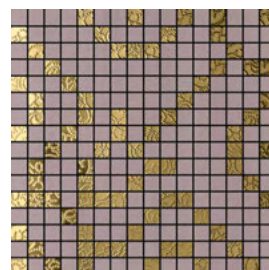

MOSAIC INSOLENC
LAVANDE
35X35 (2X2)

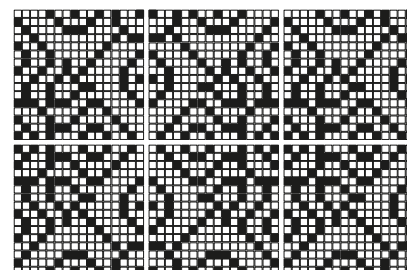

MOSAIC INSOLENC
Sugestões de aplicação · Laying suggestions
Sugestions de pose · Verlegebeispiele
Технология и способы укладки



CHÉRIE JASMIN BLANC
22,5X45

STOCK OFF BARRA CHÉRIE
JASMIN BLANC
5X45



CHÉRIE VANILLE
22,5X45

STOCK OFF BARRA CHÉRIE
VANILLE
5X45



CHÉRIE AMBRE GRIS
22,5X45

STOCK OFF BARRA CHÉRIE
AMBRE GRIS
5X45



CHÉRIE CANNELLE
22,5X45

STOCK OFF BARRA CHÉRIE
CANNELLE
5X45



CHÉRIE LYS BLEU
22,5X45

STOCK OFF BARRA CHÉRIE
LYS BLEU
5X45



CHÉRIE LAVANDE
22,5X45

STOCK OFF BARRA CHÉRIE
LAVANDE
5X45



LISTELO ORO
1X100

BARRA INOX BRILHO
1X100



BARRA POÈME D'OR
4,5X35



BARRA POÈME D'ARGENT
4,5X35



BARRA FRAGRANCE CANNELLE
5X100



BARRA FRAGRANCE LYS BLEU
5X100



BARRA FRAGRANCE LAVANDE
5X100



FRAGRANCE CANNELLE
22,5X45
BARRA FRAGRANCE CANNELLE
5X45



BARRA FRAGRANCE CANNELLE
5X22,5



BARRA EVIDENCE CANNELLE
5X22,5
STOCK OFF



BARRA EVIDENCE CANNELLE
5X45
STOCK OFF



FRAGRANCE LYS BLEU
22,5X45
BARRA FRAGRANCE LYS BLEU
5X45



BARRA FRAGRANCE LYS BLEU
5X22,5



BARRA EVIDENCE LYS BLEU
5X22,5
STOCK OFF



BARRA EVIDENCE LYS BLEU
5X45
STOCK OFF

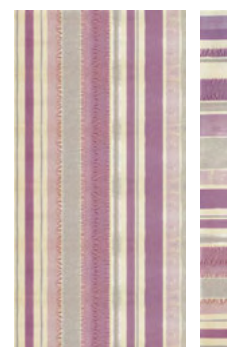

FRAGRANCE LAVANDE
22,5X45
BARRA FRAGRANCE LAVANDE
5X45



BARRA FRAGRANCE LAVANDE
5X22,5



BARRA EVIDENCE LAVANDE
5X22,5
STOCK OFF



BARRA EVIDENCE LAVANDE
5X45
STOCK OFF

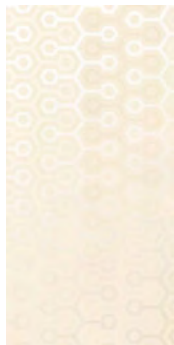

✕ HYPNOTIC JASMIN BLANC
22,5X45



✕ HYPNOTIC VANILLE
22,5X45



✕ HYPNOTIC CANNELLE
22,5X45

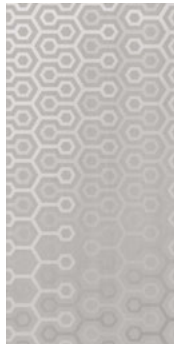

✕ HYPNOTIC AMBRE GRIS
22,5X45

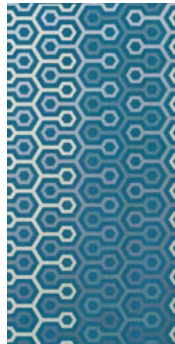

✕ HYPNOTIC LYS BLEU
22,5X45

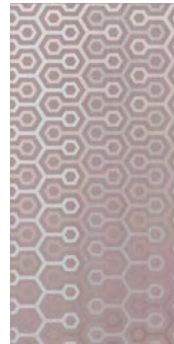

✕ HYPNOTIC LAVANDE
22,5X45



m²

GOLD MIRAGE
22,5X45



✕ BARRA AMOUR JASMIN BLANC
5X45
STOCK OFF



✕ BARRA AMOUR VANILLE
5X45
STOCK OFF



✕ BARRA AMOUR CANNELLE
5X45
STOCK OFF



✕ BARRA AMOUR AMBRE GRIS
5X45
STOCK OFF



✕ BARRA AMOUR LYS BLEU
5X45
STOCK OFF



✕ BARRA AMOUR LAVANDE
5X45
STOCK OFF



PAVIMENTOS COORDENADOS
 COORDINATED FLOOR TILES
 SOLS COORDONNÉS
 KOORDINIERTE BODEN FLIESEN
 КООРДИНИРОВАННАЯ НАПОЛЬНАЯ ПЛИТКА

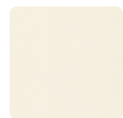

PARFUM JASMIN BLANC



PARFUM VANILLE

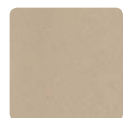

PARFUM CANNELLE





PAVIMENTOS COORDENADOS
 COORDINATED FLOOR TILES
 SOLS COORDONNÉS
 KOORDINIERTE BODEN FLIESEN
 КООРДИНИРОВАННАЯ НАПОЛЬНАЯ ПЛИТКА





CHARM



REVESTIMENTO COM ACABAMENTO BRILHO
GLOSSY WALL TILES
FAÏANCES AVEC FINITION BRILLANT
WANDFLIESEN - GLÄNZEND OBERFLÄCHE
НАСТЕННАЯ КЕРАМИЧЕСКАЯ ПЛИТКА С ГЛЯНЦЕВЫМ ПОКРЫТИЕМ



35x100

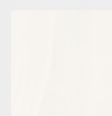

WHITE

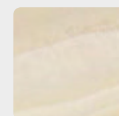

BEIGE

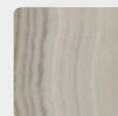

GREY

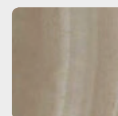

BROWN

PAVIMENTO COM ACABAMENTO MATE OU SEMI-BRILHO
MATT OR GLOSSY FLOOR TILES
CARREAUX SOL EN FINITION MAT OU SEMI-BRILLANT.
BODENFLIESEN - MATT ODER HALBMATT OBERFLÄCHE
НАПОЛЬНАЯ ПЛИТКА С МАТОВЫМ ИЛИ ПОЛУ-ГЛЯНЦЕВЫМ ПОКРЫТИЕМ



35x35



WHITE

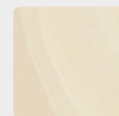

BEIGE

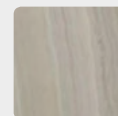

GREY

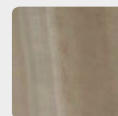

BROWN

CHARM





CHARM



CHARM WHITE
35X100 RET.

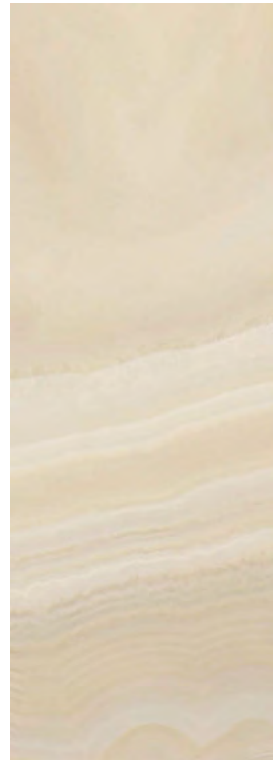

CHARM BEIGE
35X100 RET.

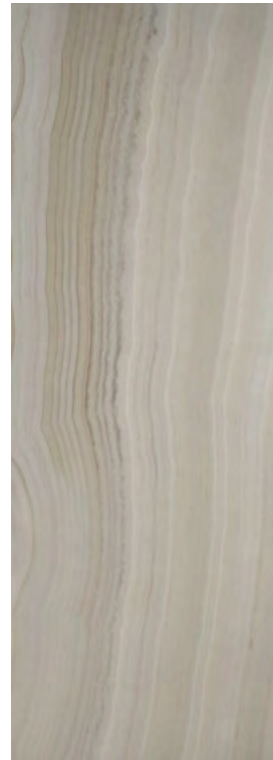

CHARM GREY
35X100 RET.

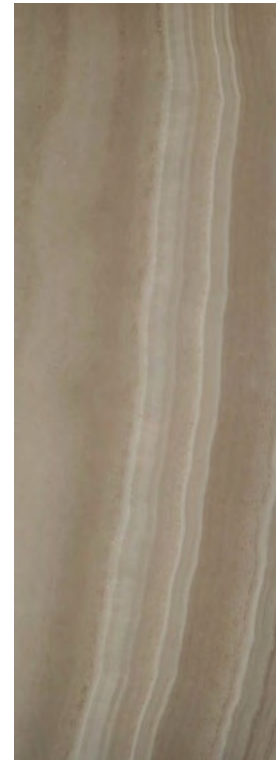

CHARM BROWN
35X100 RET.

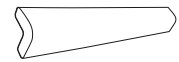

PERFIL CHARM
1,7X50



CHARM WHITE
35X35 RET.

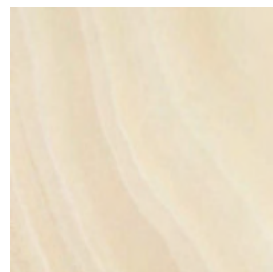

CHARM BEIGE
35X35 RET.

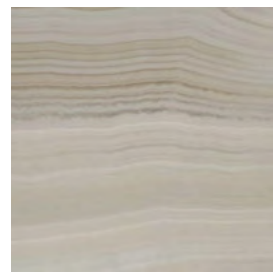

CHARM GREY
35X35 RET.

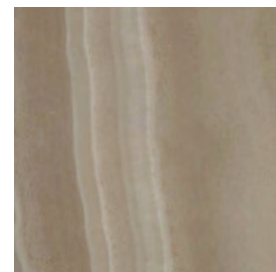

CHARM BROWN
35X35 RET.



TACO CHARM WHITE
7X7



TACO CHARM BEIGE
7X7



TIRA CHARM GREY
7X35

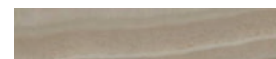

TIRA CHARM BROWN
7X35



12mm
10,5mm



m²

CHARM FLOW WHITE
35X100 RET.



m²

CHARM FLOW BEIGE
35X100 RET.



m²

CHARM FLOW GREY
35X100 RET.



m²

CHARM FLOW BROWN
35X100 RET.

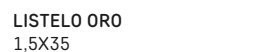

LISTELO ORO
1,5X35



LISTELO ORO
1X100



CALHA AÇO INOX ESMERILADA
1X250 (1X1,3X250)
STOCK OFF

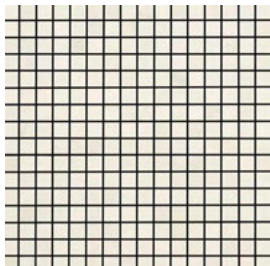

MOSAICO CHARM WHITE
35X35 (1,9X1,9)

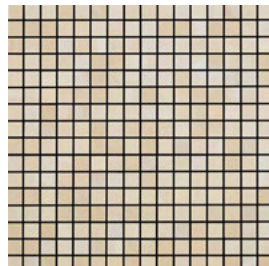

MOSAICO CHARM BEIGE
35X35 (1,9X1,9)

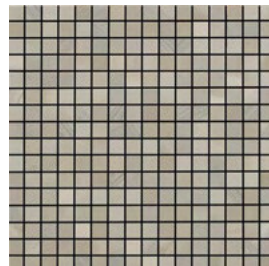

MOSAICO CHARM GREY
35X35 (1,9X1,9)

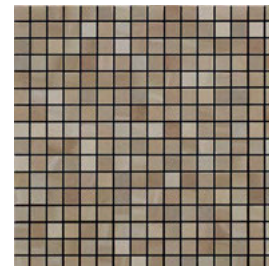

MOSAICO CHARM BROWN
35X35 (1,9X1,9)

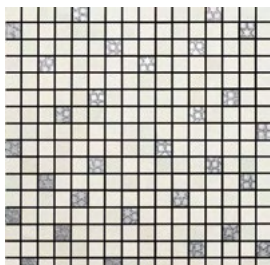

MOSAICO DELIGHT WHITE
35X35 (1,9X1,9)

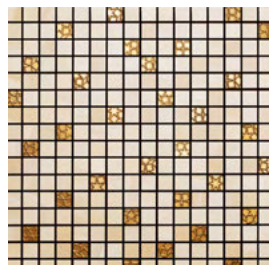

MOSAICO DELIGHT BEIGE
35X35 (1,9X1,9)



MOSAICO DELIGHT GREY
35X35 (1,9X1,9)

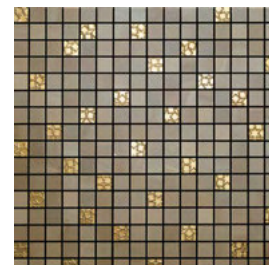

MOSAICO DELIGHT BROWN
35X35 (1,9X1,9)

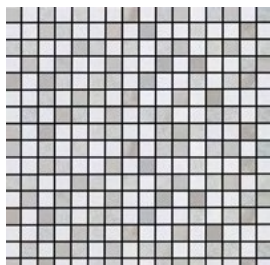

**MOSAICO ROMANTIC
WHITE/GREY**
35X35 (1,9X1,9)

> STOCK OFF

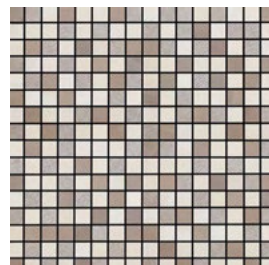

**MOSAICO ROMANTIC
BEIGE/BROWN**
35X35 (1,9X1,9)

> STOCK OFF

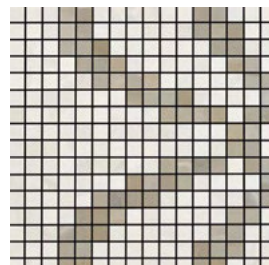

**MOSAICO INTENSE
WHITE/GREY**
35X35 (1,9X1,9)

> STOCK OFF

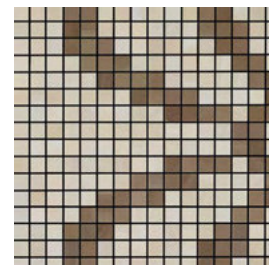

**MOSAICO INTENSE
BEIGE/BROWN**
35X35 (1,9X1,9)

> STOCK OFF

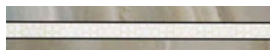

**BARRA MAGIC
WHITE/GREY**
6,3X35

> STOCK OFF



**BARRA MAGIC
BEIGE/BROWN**
6,3X35

> STOCK OFF

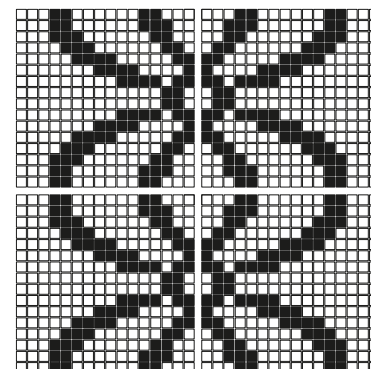

MOSAICO INTENSE
Sugestões de aplicação · Laying suggestions
Sugestões de pose · Verlegebeispiele
Технология и способы укладки



WONDER



REVESTIMENTO ESTRUTURADO COM ACABAMENTO BRILHO
GLOSSY STRUCTURED WALL TILES
FAIÁNCES STRUCTURÉ EN FINITION BRILLANT
STRUKTURIERTE WANDFLIESEN - GLÄNZEND OBERFLÄCHE
НАСТЕННАЯ СТРУКТУРИРОВАННАЯ ПЛИТКА С ГЛЯНЦЕВЫМ ПОКРЫТИЕМ



REVESTIMENTO ESTRUTURADO COM ACABAMENTO MATE OU SEMI-BRILHO
MATT OR GLOSSY STRUCTURED WALL TILES
FAIÁNCES STRUCTURÉ EN FINITION MAT OU SEMI-BRILLANT
STRUKTURIERTE WANDFLIESEN - MATT ODER HALBMATT OBERFLÄCHE
НАСТЕННАЯ СТРУКТУРИРОВАННАЯ ПЛИТКА С МАТОВЫМ ИЛИ ПОЛУ-ГЛЯНЦЕВЫМ ПОКРЫТИЕМ



35x100 13,5mm / 12mm 13,4mm / 12mm 13,3mm / 12mm 12mm / 10,6mm

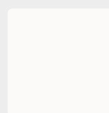

WHITE

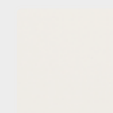

MATT WHITE

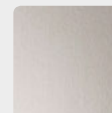

MATT CHROME



MIRROR

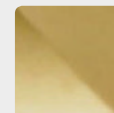

GOLD

30x60 11mm / 10mm

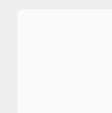

WHITE

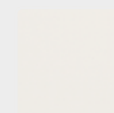

MATT WHITE

22x45 12,8mm / 9mm 10,7mm / 9mm 10,4mm / 9mm

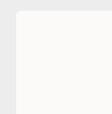

WHITE



MIRROR

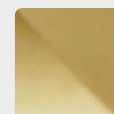

GOLD

REVESTIMENTO COM ACABAMENTO BRILHO
GLOSSY WALL TILES
FAIÁNCES AVEC FINITION BRILLANT
WANDFLIESEN - GLÄNZEND OBERFLÄCHE
НАСТЕННАЯ КЕРАМИЧЕСКАЯ ПЛИТКА С ГЛЯНЦЕВЫМ ПОКРЫТИЕМ



35x100 12mm

22x45 9mm



BLACK

XXXX
XXXX
XXXX

WONDER

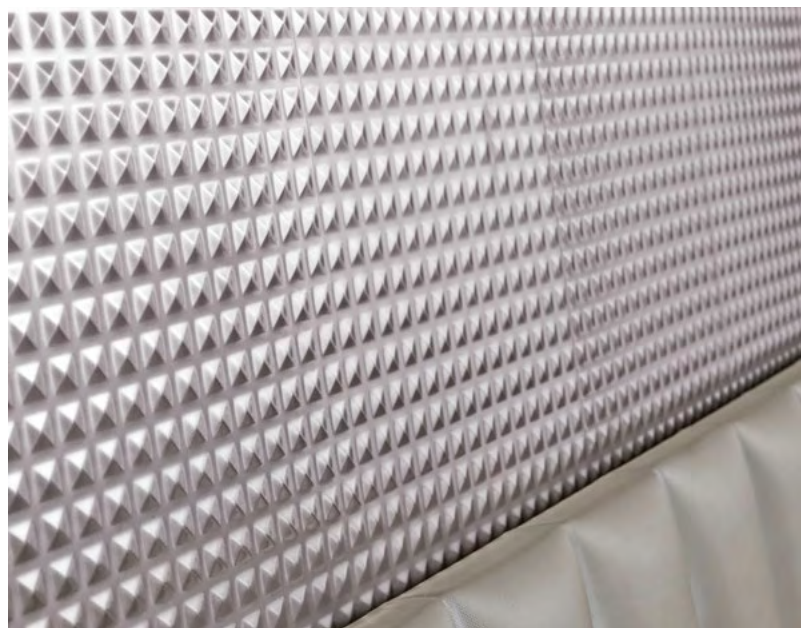







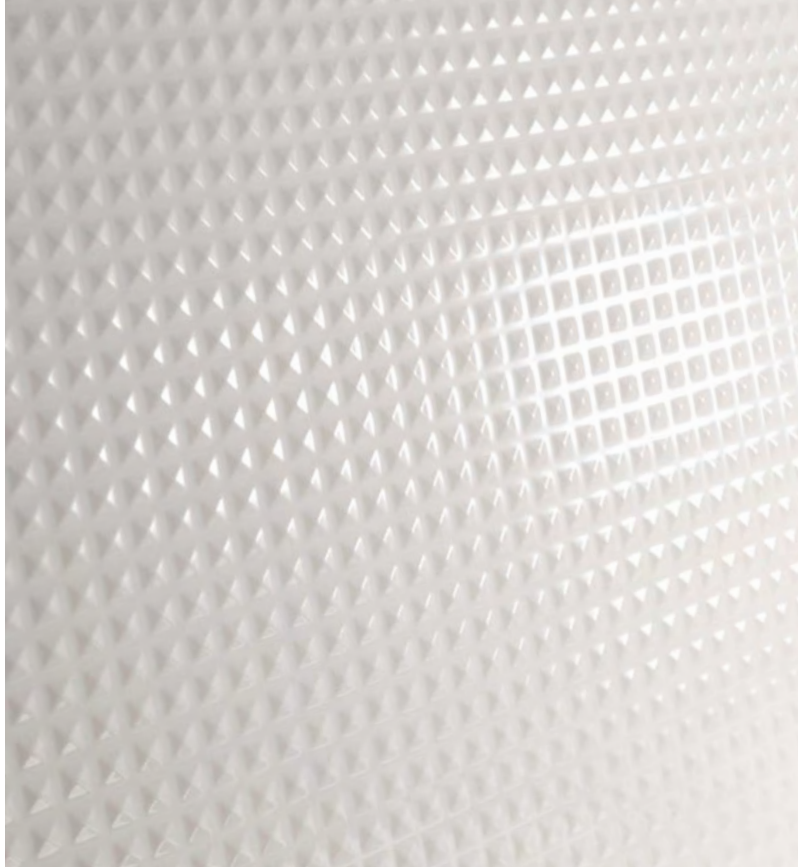



XXXX
XXXX
XXXX
XXXX
WONDER



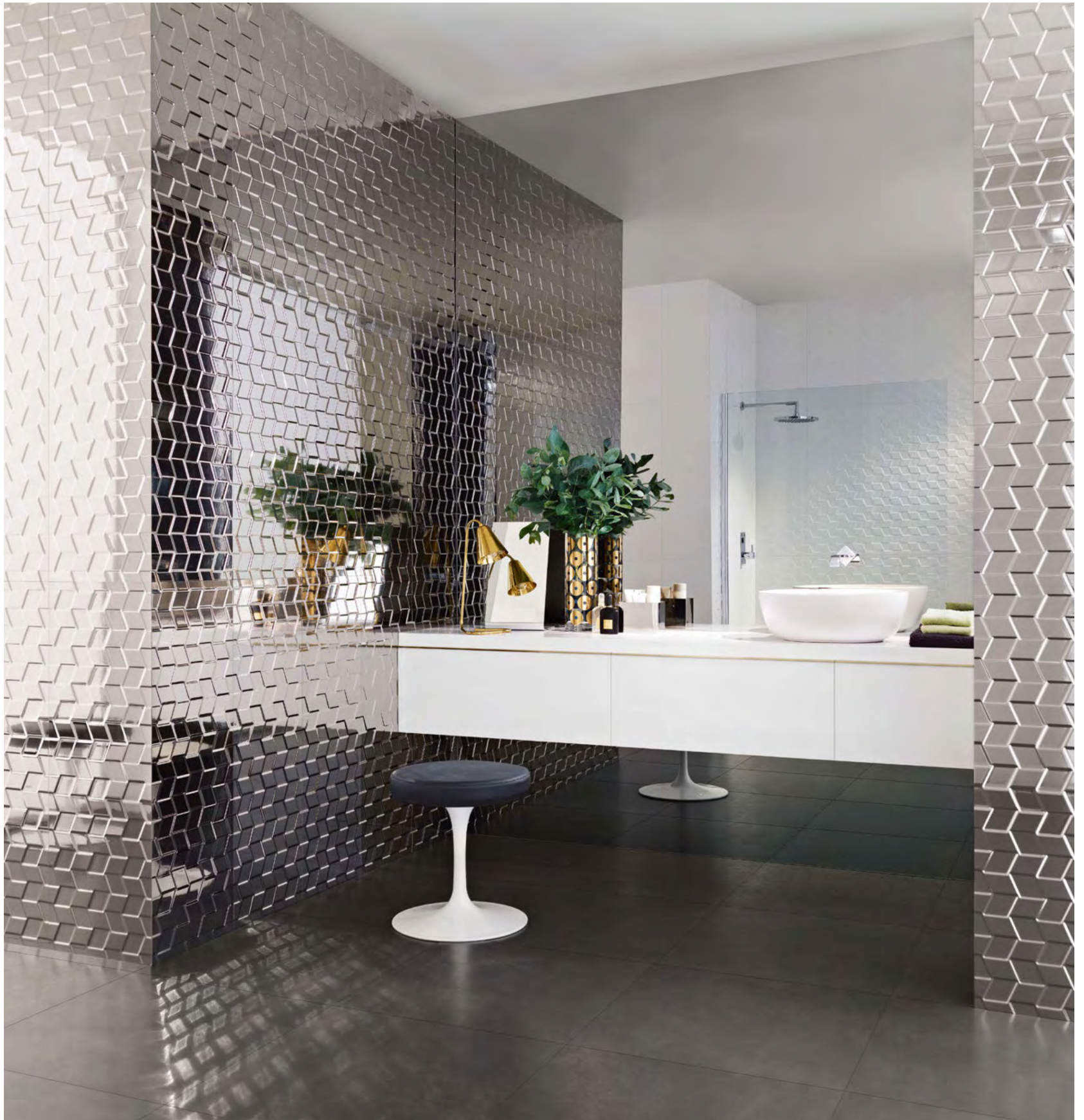

MIRROR ENIGMA 35X100 RET. || WONDER WHITE ENIGMA 35X100 RET. || PLACE ANTRACITE 59,2X59,2 RET.



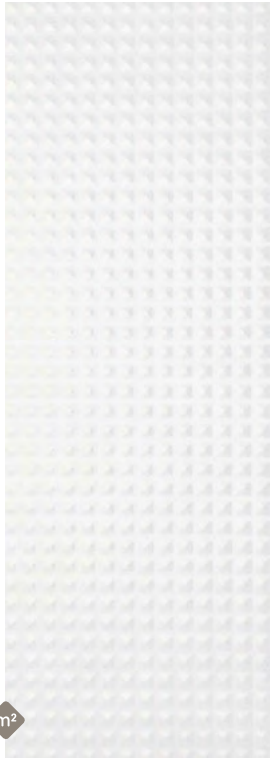
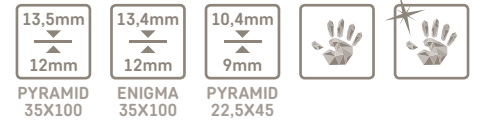

m²

✕ **WONDER WHITE PYRAMID**
35X100 RET.
22,5X45

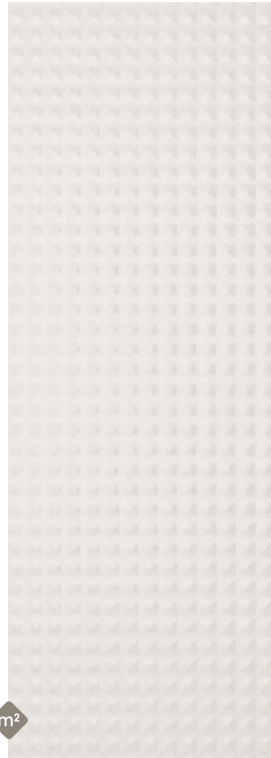

m²

✕ **WONDER MATT WHITE PYRAMID**
35X100 RET.
22,5X45

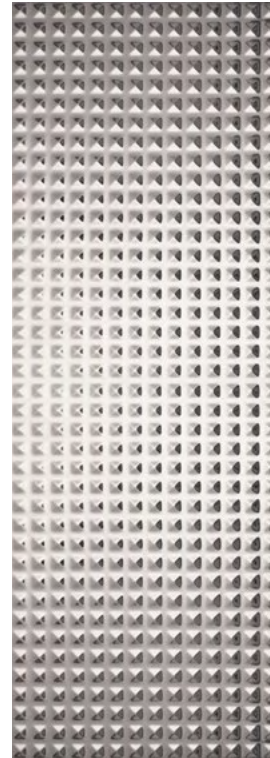

✕ **MIRROR PYRAMID**
35X100 RET.

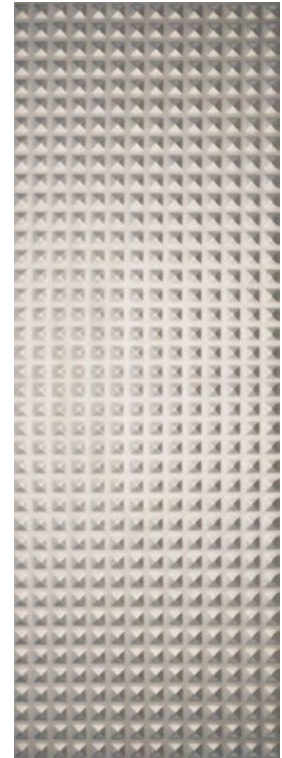

✕ **MATT CHROME PYRAMID**
35X100 RET.

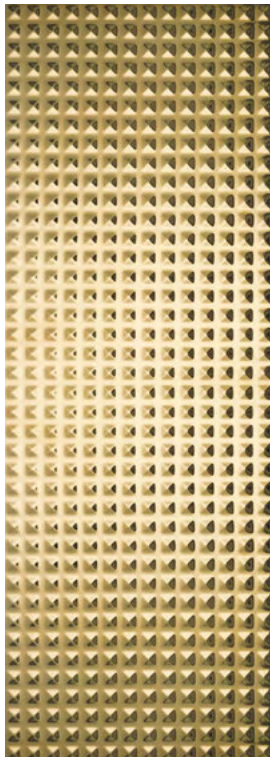

✕ **GOLD PYRAMID**
35X100 RET.

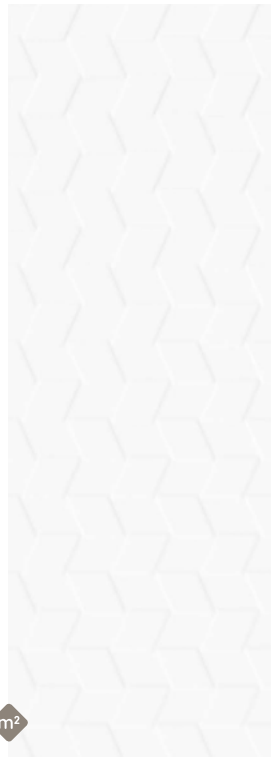

m²

✕ **WONDER WHITE ENIGMA**
35X100 RET.

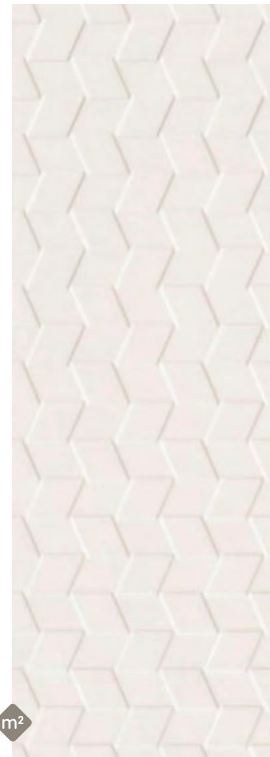

m²

✕ **WONDER MATT WHITE ENIGMA**
35X100 RET.

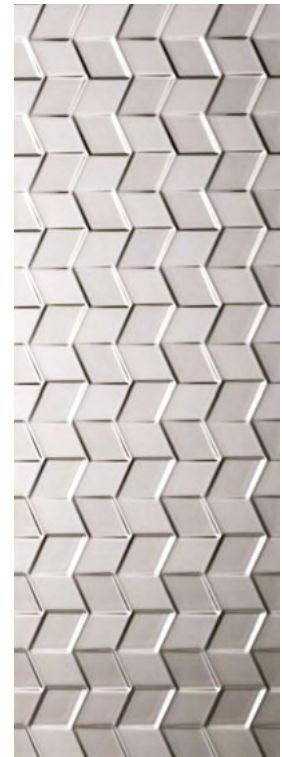

✕ **MIRROR ENIGMA**
35X100 RET.



WONDER



13,3mm
12mm
LINE UP
SHAPE

12mm
10,6mm
FLOW

12mm
35X100

11mm
10mm
30X60

9mm
22,5X45



m²
X **WHITE SHAPE**
35X100 RET.



m²
X **MATT WHITE SHAPE**
35X100 RET.

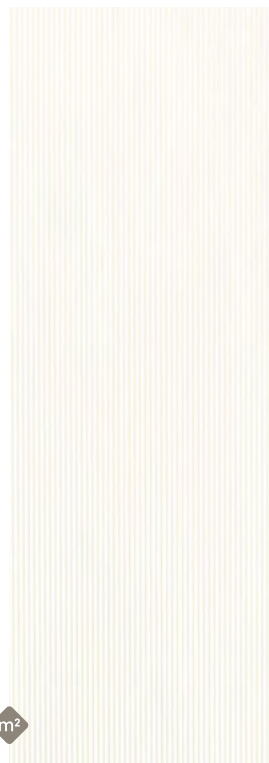

m²
X **WONDER WHITE SOFTNESS**
35X100 RET.
22,5X45

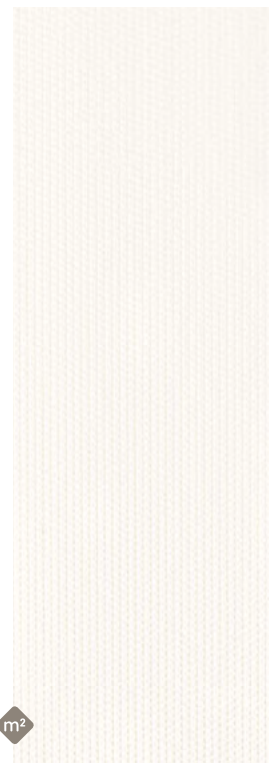

m²
X **WONDER WHITE BOUNDARIES**
35X100 RET.
22,5X45



m²
X **WONDER WHITE LINE UP**
35X100 RET.



m²
X **WONDER MATT WHITE LINE UP**
35X100 RET.

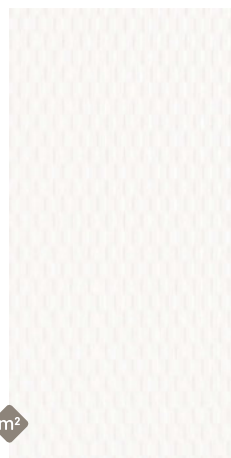

m²
X **WONDER WHITE MYSTERY**
30X60 RET.



m²
X **WONDER MATT WHITE MYSTERY**
30X60 RET.



× **WHITE DIAMOND**
22,5X45

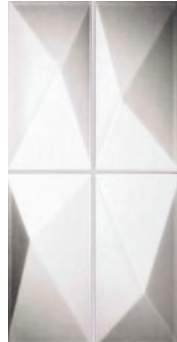

× **MIRROR DIAMOND**
22,5X45

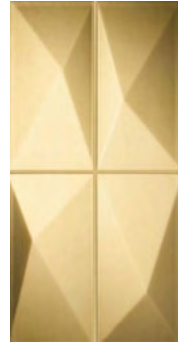

× **GOLD DIAMOND**
22,5X45



× **WHITE FORM**
22,5X45

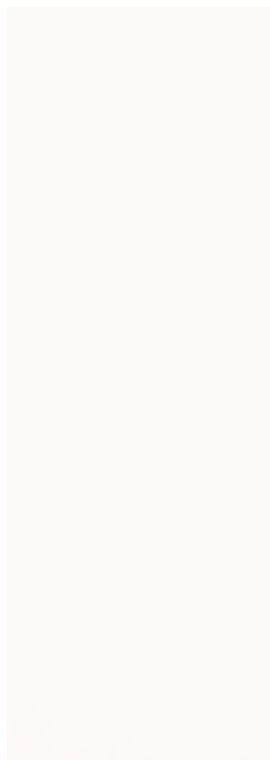
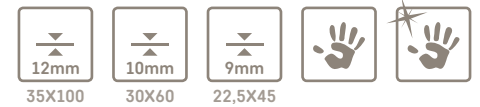

× **LIGHT BRANCO BRILHO**
35X100 RET.
30X60 RET.
22,5X45

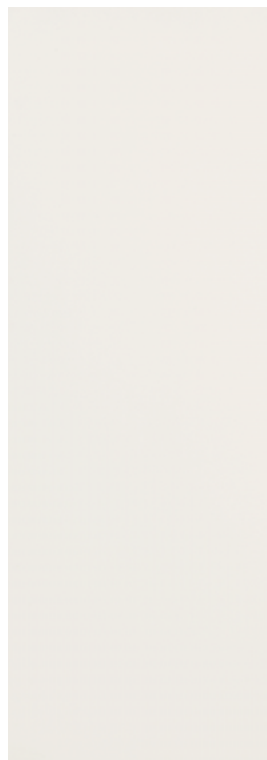

LIGHT MATT WHITE
35X100 RET.
30X60 RET.
22,5X45



× **WONDER BLACK**
35X100 RET. LM-3710
22,5X45 LM-3310

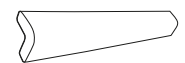

PERFIL LIGHT
1,7X50
1,7X35

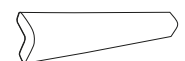

PERFIL WONDER
1,7X50





Coleção
Collection
Kollektion
Коллекция

DELUXE



REVESTIMENTO COM ACABAMENTO BRILHO
GLOSSY WALL TILES
FAÏANCES AVEC FINITION BRILLANT
WANDFLIESEN - GLÄNZEND OBERFLÄCHE
НАСТЕННАЯ КЕРАМИЧЕСКАЯ ПЛИТКА С ГЛЯНЦЕВЫМ ПОКРЫТИЕМ



35x100  12mm

35x70  10,8mm

22x45  9mm

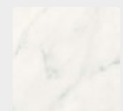

CARRARA

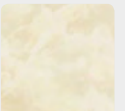

ONICE

PAVIMENTO COM ACABAMENTO BRILHO OU SATINADO
FLOOR TILES WITH BRIGHT OR HONED FINISH
REVÊTEMENT DE SOL AVEC FINITION BRILLANTE OU SATINÉE
BODENBELAG MIT GLÄNZENDER ODER MATTER OBERFLÄCHE
ПОВЕРХНОСТЬ С ГЛЯНЦЕВЫМ ИЛИ МАТОВЫМ ПОКРЫТИЕМ



PAVIMENTO COM ACABAMENTO MATE OU SEMI-BRILHO
MATT OR GLOSSY FLOOR TILES
CARREAUX SOL EN FINITION MAT OU SEMI-BRILLANT
BODENFLIESEN - MATT ODER HALBMATT OBERFLÄCHE
НАПОЛЬНАЯ ПЛИТКА С МАТОВЫМ ИЛИ ПОЛУ-ГЛЯНЦЕВЫМ ПОКРЫТИЕМ



45x45  9mm

35x35  9mm

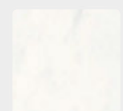

CARRARA

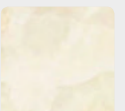

ONICE

DELUXE



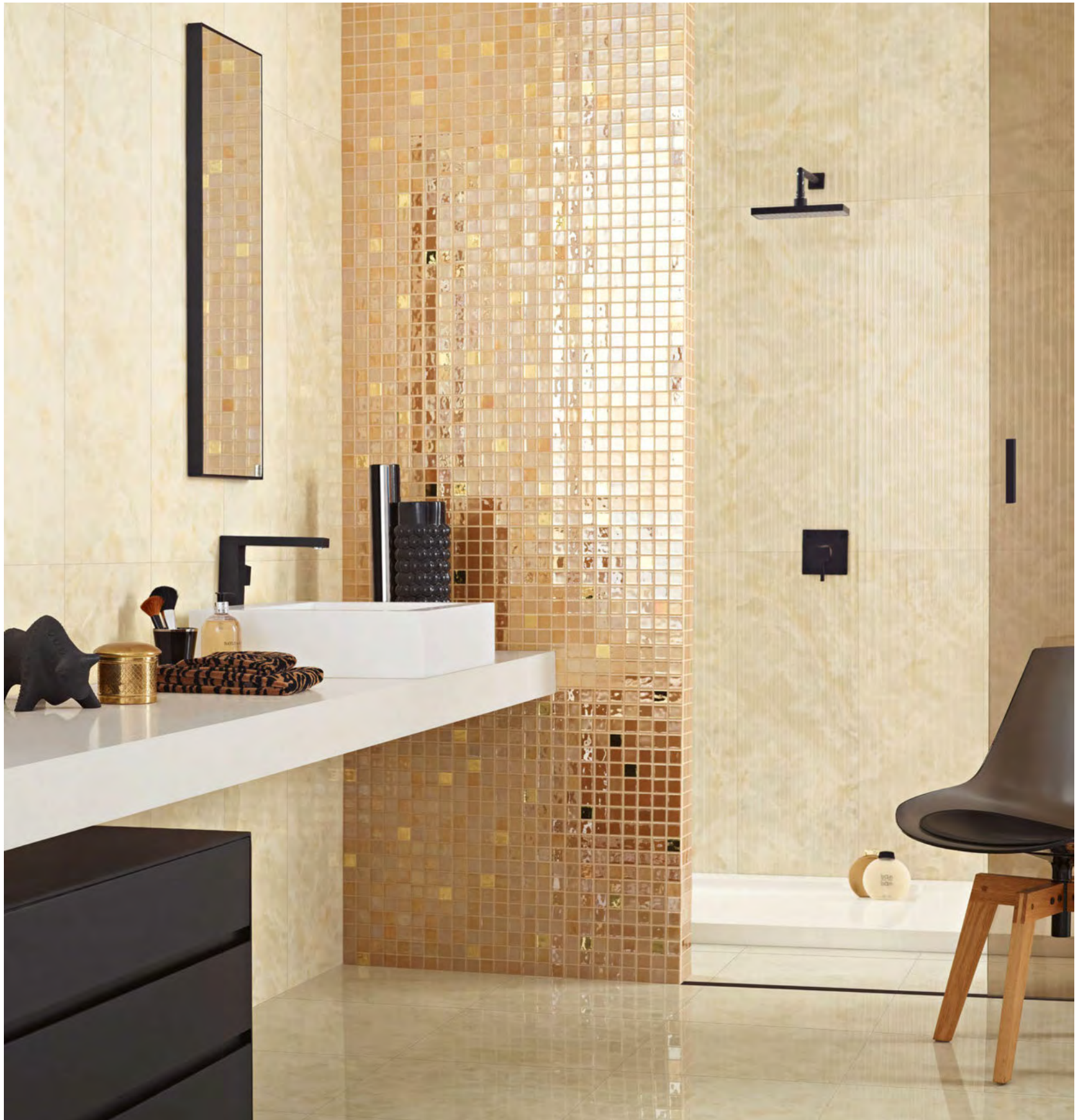

FLOW ONICE DELUXE 35X100 RET. || ONICE DELUXE 35X100 RET. || MOSAICO GOLD MIX 27,4X27,4 || ONICE DELUXE 44X44 POL. RET.

DELUXE

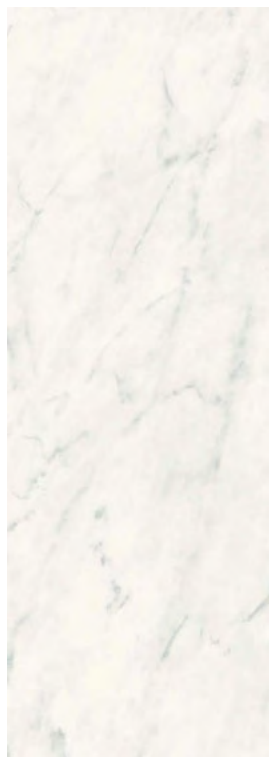

CARRARA DELUXE
35X100 RET.
35X70 RET.
22,5X45

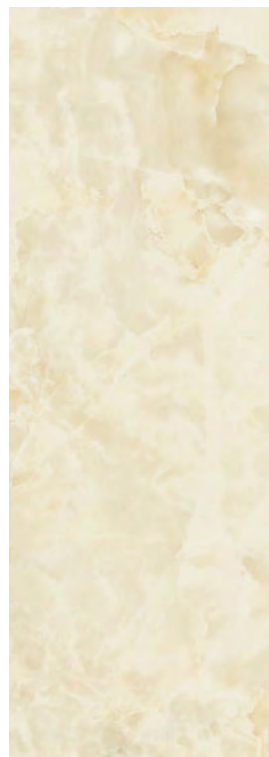

ONICE DELUXE
35X100 RET.
35X70 RET.
22,5X45



PERFIL DELUXE
1,7X50
1,7X35

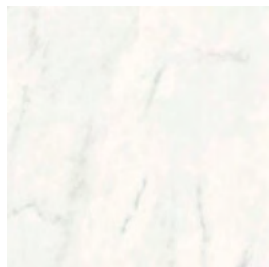

CARRARA DELUXE
45X45 NAT.
44X44 POL. RET.
35X35 POL. RET.

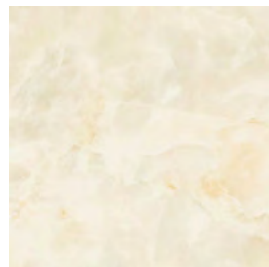

ONICE DELUXE
45X45 NAT.
44X44 POL. RET.
35X35 POL. RET.

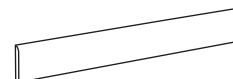

RODAPÉ DELUXE
8X45



TACO SILVER
7,5X7,5



TACO GOLD
7,5X7,5



TACO SILVER RELIEF
7,5X7,5



TACO GOLD RELIEF
7,5X7,5



m²

SHAPE CARRARA DELUXE
35X100 RET.



m²

FLOW CARRARA DELUXE
35X100 RET.



CARRARA EMPIRE
35X100 RET.

STOCK OFF 35X70 RET.



CARRARA EXCLUSIVE
35X100 RET.

STOCK OFF 35X70 RET.



CARRARA MAGESTIC
35X100 RET.

STOCK OFF 35X70 RET.



m²

SHAPE ONICE DELUXE
35X100 RET.



m²

FLOW ONICE DELUXE
35X100 RET.



ONICE EMPIRE
35X100 RET.

STOCK OFF 35X70 RET.



ONICE EXCLUSIVE
35X100 RET.

STOCK OFF 35X70 RET.



ONICE MAGESTIC
35X100 RET.

STOCK OFF 35X70 RET.



1X45



BARRA CARRARA LUSTER
11X100 RET.
STOCK OFF



BARRA CARRARA LUSTER
8X35
STOCK OFF



BARRA ONICE LUSTER
11X100 RET.
STOCK OFF



BARRA ONICE LUSTER
8X35
STOCK OFF



BARRA SUBLIME WHITE
10X35
STOCK OFF



BARRA SUBLIME BEIGE
10X35
STOCK OFF

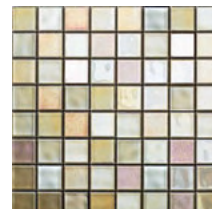

MOSAICO SILVER MIX
27,4X27,4 (3,3X3,3)



LISTELO SUBLIME WHITE
3,2X35
STOCK OFF



LISTELO SUBLIME BEIGE
3,2X35
STOCK OFF



MOSAICO GOLD MIX
27,4X27,4 (3,3X3,3)



BARRA GRACE WHITE
10X35
STOCK OFF



BARRA GRACE BEIGE
10X35
STOCK OFF



LISTELO FAIR WHITE
1X45
STOCK OFF



BARRA CARRARA EXCLUSIVE
10X35



BARRA ONICE EXCLUSIVE
10X35



LISTELO FAIR SILVER
1X45
STOCK OFF



BARRA CARRARA EMPIRE
9,5X35



BARRA ONICE EMPIRE
9,5X35



LISTELO FAIR GOLD
1X45
STOCK OFF



m²

CARRARA DELUXE
PRÉ-CORTE MOSAICO
22,5X45



m²

ONICE DELUXE
PRÉ-CORTE MOSAICO
22,5X45



CARRARA VOGUE
22,5X45

STOCK OFF

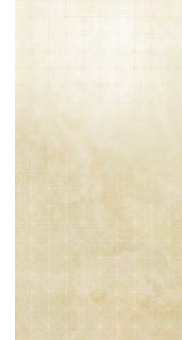

ONICE VOGUE
22,5X45

STOCK OFF

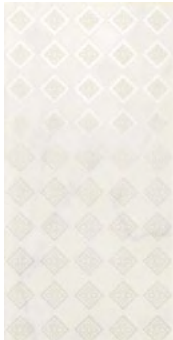

CARRARA DIVINE
22,5X45

STOCK OFF

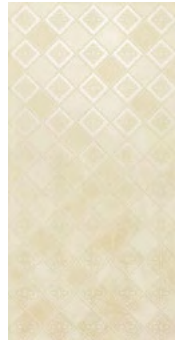

ONICE DIVINE
22,5X45

STOCK OFF



CARRARA DECOR VOGUE
22,5X45



ONICE DECOR VOGUE
22,5X45



CARRARA REFINE
22,5X45

STOCK OFF



ONICE REFINE
22,5X45



BARRA CARRARA SELECT
6,9X22,5

STOCK OFF



BARRA ONICE SELECT
6,9X22,5

STOCK OFF



BARRA CARRARA SELECT
6,9X45

STOCK OFF



BARRA ONICE SELECT
6,9X45

STOCK OFF



BARRA CARRARA REFINE
7X22,5

STOCK OFF



BARRA ONICE REFINE
7X22,5

STOCK OFF

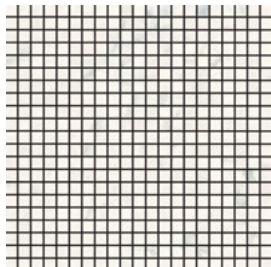

MOSAICO CARRARA DELUXE
35X35 (1,47X1,47)

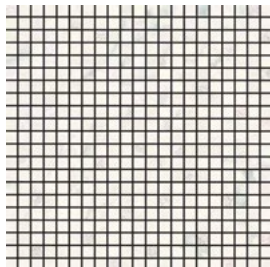

MOSAICO CARRARA PRESTIGE
35X35 (1,47X1,47)

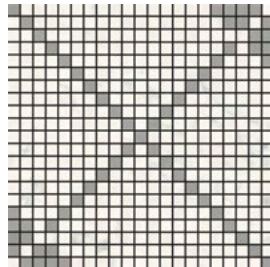

MOSAICO CARRARA ELITE
35X35 (1,47X1,47)
STOCK OFF

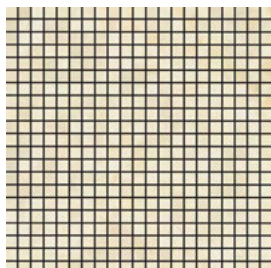

MOSAICO ONICE DELUXE
35X35 (1,47X1,47)

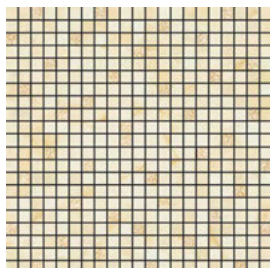

MOSAICO ONICE PRESTIGE
35X35 (1,47X1,47)

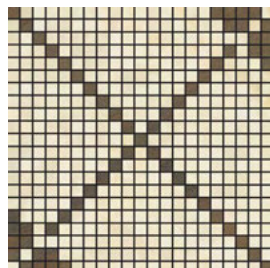

MOSAICO ONICE ELITE
35X35 (1,47X1,47)
STOCK OFF

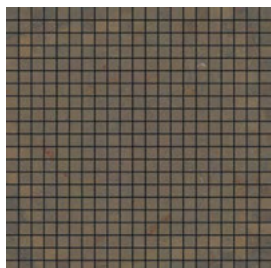

MOSAICO MEREZ DELUXE
35X35 (1,47X1,47)
STOCK OFF

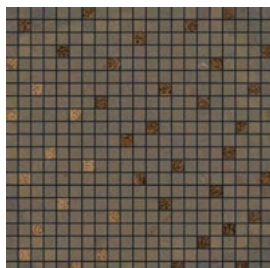

MOSAICO MEREZ PRESTIGE
35X35 (1,47X1,47)
STOCK OFF

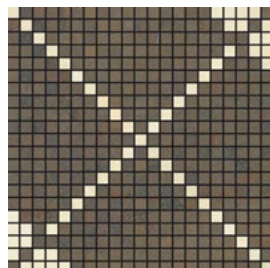

MOSAICO MEREZ ELITE
35X35 (1,47X1,47)
STOCK OFF

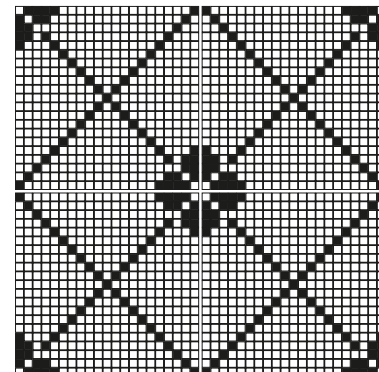

MOSAICO ELITE
SUGESTÕES DE APLICAÇÃO · LAYING SUGGESTIONS
SUGGESTIONS DE POSE · VERLEGEBEISPIELE
ТЕХНОЛОГИЯ И СПОСОБЫ УКЛАДКИ



PEÇAS ESPECIAIS - SPECIAL PIECES - PIÈCES SPÉCIALES - SPEZIALTEILE - СПЕЦИАЛЬНЫЕ ДЕКОРАТИВНЫЕ ЭЛЕМЕНТЫ

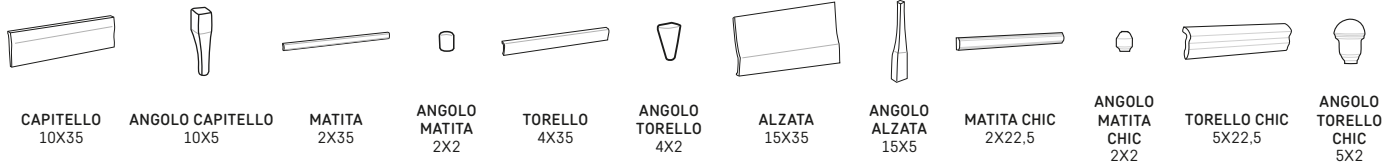

	CARRARA DELUXE	ONICE DELUXE	CINZA DELUXE
CAPITELLO 10X35	STOCK OFF	STOCK OFF	STOCK OFF
ANGOLO CAPITELLO 10X5	STOCK OFF	STOCK OFF	STOCK OFF
MATITA 2X35	STOCK OFF	STOCK OFF	STOCK OFF
ANGOLO MATITA 2X2	STOCK OFF	STOCK OFF	STOCK OFF
TORELLO 4X35	STOCK OFF	STOCK OFF	STOCK OFF
ANGOLO TORELLO 4X2	STOCK OFF	STOCK OFF	STOCK OFF
ALZATA 15X35	STOCK OFF	STOCK OFF	STOCK OFF
ANGOLO ALZATA 15X5	STOCK OFF	STOCK OFF	STOCK OFF
MATITA CHIC 2X22,5	STOCK OFF	STOCK OFF	STOCK OFF
ANGOLO MATITA CHIC 2X2	STOCK OFF	STOCK OFF	STOCK OFF
TORELLO CHIC 5X22,5	STOCK OFF	STOCK OFF	STOCK OFF
ANGOLO TORELLO CHIC 5X2	STOCK OFF	STOCK OFF	STOCK OFF

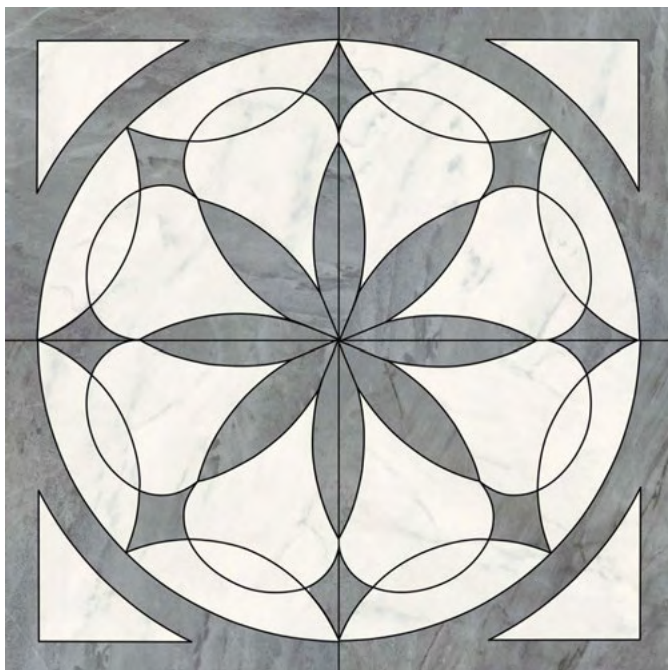

CARRARA PRIME
88X88
STOCK OFF

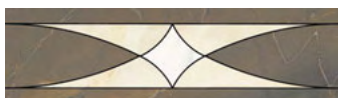

BARRA CARRARA DIAMOND
12,5X44
STOCK OFF

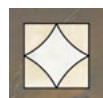

CANTO CARRARA DIAMOND
12,5X12,5
STOCK OFF



ONICE PRIME
88X88
STOCK OFF



BARRA ONICE PRIME
12,5X44
STOCK OFF

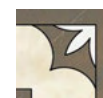

CANTO ONICE PRIME
12,5X12,5
STOCK OFF



ONICE CIRCLE
88X88
STOCK OFF



MEREZ PRIME
88X88
STOCK OFF





Coleção
Collection
Kollektion
Коллекция

PLAZA



REVESTIMENTO COM ACABAMENTO BRILHO
GLOSSY WALL TILES
FAÏANCES AVEC FINITION BRILLANT
WANDFLIESEN - GLÄNZEND OBERFLÄCHE
НАСТЕННАЯ КЕРАМИЧЕСКАЯ ПЛИТКА С ГЛЯНЦЕВЫМ ПОКРЫТИЕМ



35x100 

35x70 

22x45 

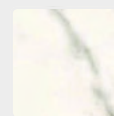

STATUARIO

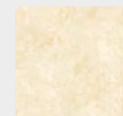

LUXURY LIGHT

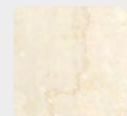

BOTTICINO
BIANCO

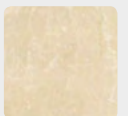

BOTTICINO
CLASSICO

PAVIMENTO COM ACABAMENTO MATE OU SEMI-BRILHO
MATT OR GLOSSY FLOOR TILES
CARREAUX SOL EN FINITION MAT OU SEMI-BRILLANT
BODENFLIESEN - MATT ODER HALBMATT OBERFLÄCHE
НАПОЛЬНАЯ ПЛИТКА С МАТОВЫМ ИЛИ ПОЛУ-ГЛЯНЦЕВЫМ ПОКРЫТИЕМ



45x45* 

35x35 



STATUARIO

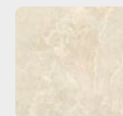

LUXURY LIGHT*

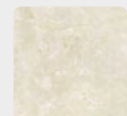

BOTTICINO
BIANCO*

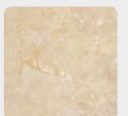

BOTTICINO
CLASSICO*

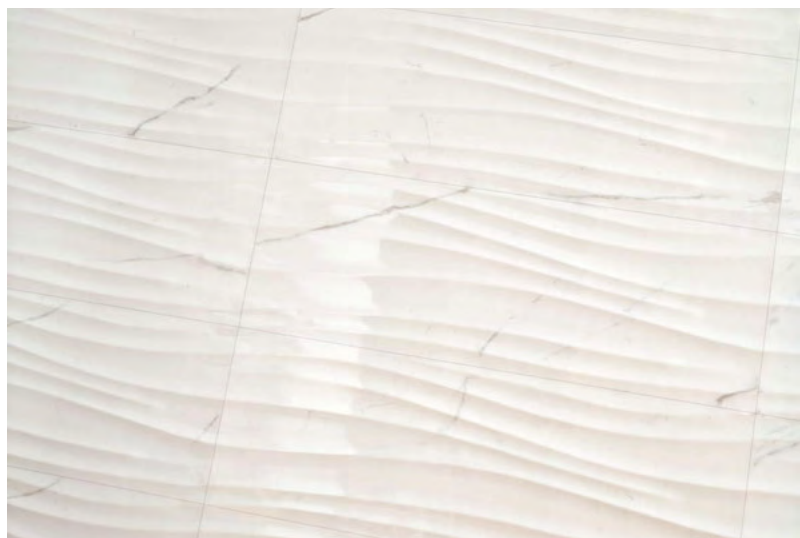











MOSAICO PLAZA DECOR GOLD 17,4X17,4





PLAZA BOTTICINO CLASSICO 22,5X45 || CUBIC BOTTICINO 22,5X45 || PLAZA BOTTICINO CLASSICO 45X45



PLAZA



PLAZA STATUARIO
35X100 RET.

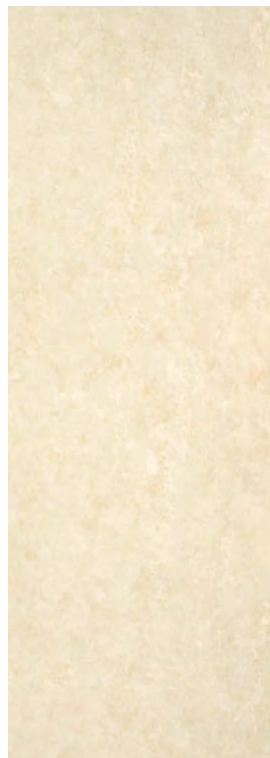

PLAZA LUXURY LIGHT
35X100 RET.
35X70 RET.
22,5X45

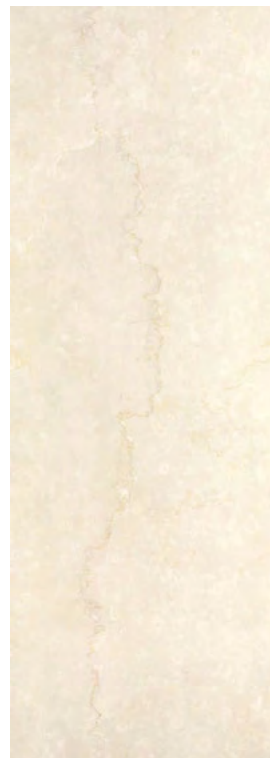

PLAZA BOTTICINO BIANCO
35X100 RET.
35X70 RET.
22,5X45

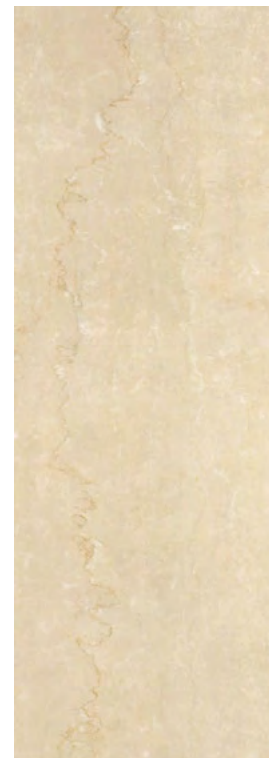

PLAZA BOTTICINO CLASSICO
35X100 RET.
35X70 RET.
22,5X45

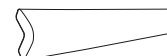

PERFIL PLAZA
1,7X50
1,7X35

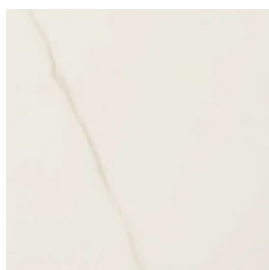

PLAZA STATUARIO
35X35 RET. LM-3580

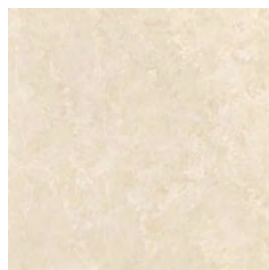

PLAZA LUXURY LIGHT
45X45
44X44 RET.
35X35 RET.

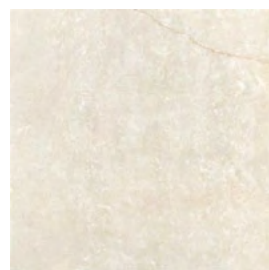

PLAZA BOTTICINO BIANCO
45X45
44X44 RET.
35X35 RET.



PLAZA BOTTICINO CLASSICO
45X45
44X44 RET.
35X35 RET.



TACO SILVER
7,5X7,5



TACO SILVER RELIEF
7,5X7,5



TACO GOLD
7,5X7,5



TACO GOLD RELIEF
7,5X7,5

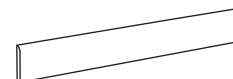

RODAPÉ PLAZA
8X45



PLAZA

13,3mm
▲
12mm
SHAPE

12mm
▲
10,5mm
FLOW

▲
12mm
35X100



m²

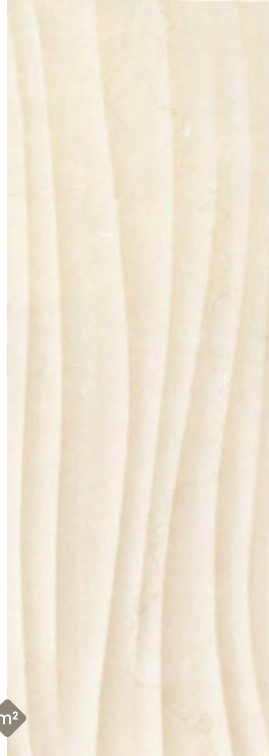

m²



m²



m²

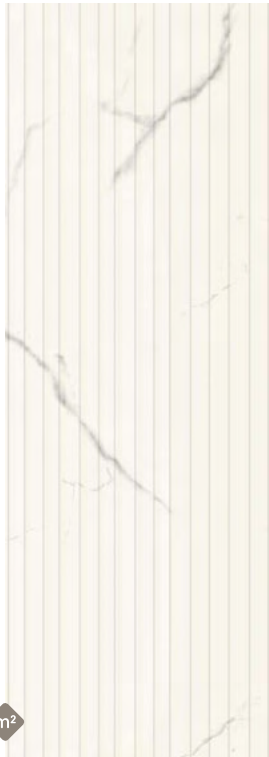

m²

FLOW STATUARIO
35x100 RET.



m²

FLOW BOTTICINO BIANCO
35x100 RET.



m²

FLOW BOTTICINO CLASSICO
35x100 RET.



m²

FLOW LUXURY LIGHT
35x100 RET.

XXXX
XXXX
XXXX

PLAZA



ELEGANCE LIGHT
35X100 RET.

STOCK OFF 35X70 RET.



ELEGANCE BIANCO
35X100 RET.

STOCK OFF 35X70 RET.

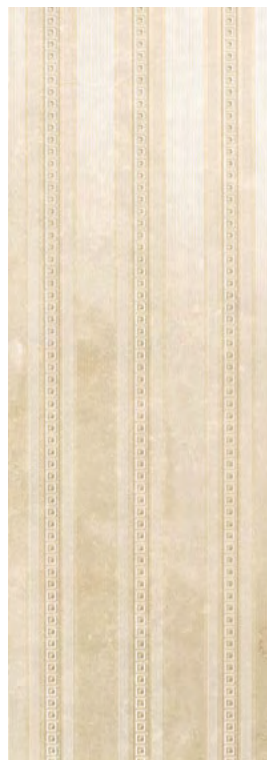

ELEGANCE CLASSIC
35X100 RET.

STOCK OFF 35X70 RET.



BARRA ELEGANCE LIGHT
10,3X35



BARRA ELEGANCE BIANCO
10,3X35



BARRA ELEGANCE CLASSIC
10,3X35



CLAIRE LIGHT
35X100 RET.
35X70 RET.

STOCK OFF



CLAIRE BIANCO
35X100 RET.
35X70 RET.

STOCK OFF



CLAIRE CLASSIC
35X100 RET.
35X70 RET.

STOCK OFF



RANDOM ART

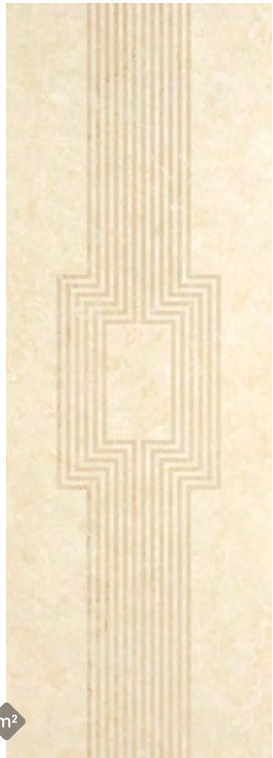

m²

SPLENDOR LUXURY LIGHT
35X100 RET.
35X70 RET.

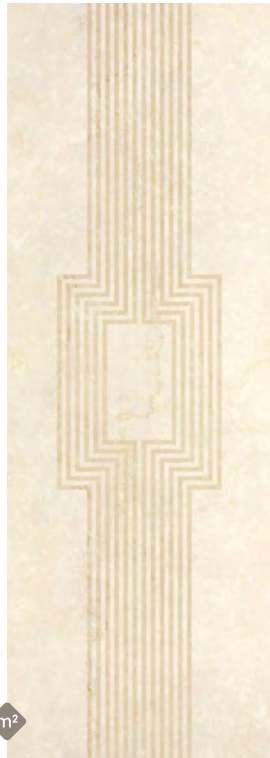

m²

SPLENDOR BOTTICINO BIANCO
35x100 RET.
35X70 RET.



m²

SPLENDOR BOTTICINO CLASSICO
35x100 RET.
35X70 RET.



m²

MELODY LUXURY LIGHT
35X100 RET.
35X70 RET.



m²

MELODY BOTTICINO
35X100 RET.
35X70 RET.



BARRA INCANTO
5X35
STOCK OFF



BARRA INCANTO CLASSICO
5X35
STOCK OFF

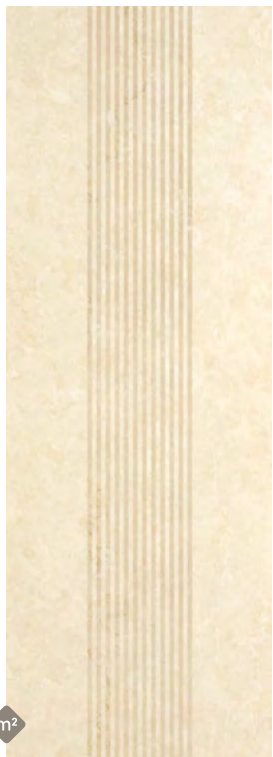

m²

SPLENDOR LINE LUXURY LIGHT
35X100 RET.
35X70 RET.



m²

SPLENDOR LINE BOTTICINO BIANCO
35X100 RET.
35X70 RET.



m²

SPLENDOR LINE BOTTICINO CLASSICO
35X100 RET.
35X70 RET.

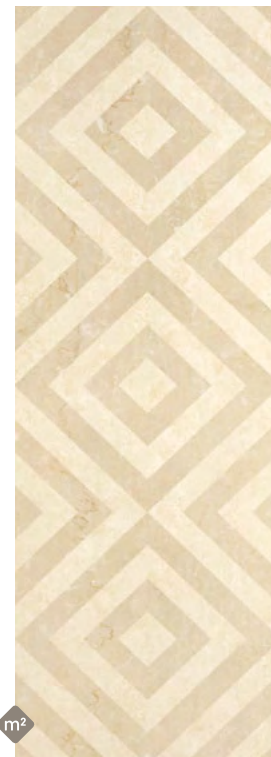

m²

DIAMONDS LUXURY LIGHT
35X100 RET.
35X70 RET.



m²

DIAMONDS BOTTICINO
35X100 RET.
35X70 RET.

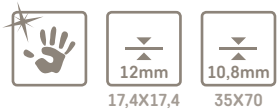

DELICATE LIGHT
35X70 RET.



DELICATE BIANCO
35X70 RET.



DELICATE CLASSICO
35X70 RET.

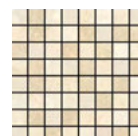

MOSAICO PLAZA
DECOR SHINE
17,4X17,4 (1,9X1,9)

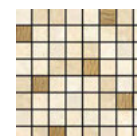

MOSAICO PLAZA
DECOR GOLD
17,4X17,4 (1,9X1,9)

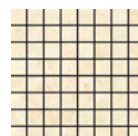

MOSAICO PLAZA
LUXURY LIGHT
17,4X17,4 (1,9X1,9)

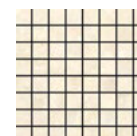

MOSAICO PLAZA
BOTTICINO BIANCO
17,4X17,4 (1,9X1,9)

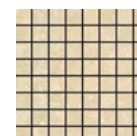

MOSAICO PLAZA
BOTTICINO CLASSICO
17,4X17,4 (1,9X1,9)

LISTELO ORO
1,5X35

LISTELO GLITTER
1,5X35

LISTELO ORO
1X100

CALHA AÇO INOX ESMERILADA
1X250 (1X1,3X250)
STOCK OFF



PEÇAS ESPECIAIS - SPECIAL PIECES - PIÈCES SPÉCIALES - SPEZIALTEILE - СПЕЦИАЛЬНЫЕ ДЕКОРАТИВНЫЕ ЭЛЕМЕНТЫ

	CAPITELLO 10X35	ANGOLO CAPITELLO 5X10	MATITA 2X35	ANGOLO MATITA 2X2	TORELLO 4X35	ANGOLO TORELLO 2X4	ALZATA 15X35	ANGOLO ALZATA 5X15
PLAZA STATUARIO	STOCK OFF	STOCK OFF	STOCK OFF	STOCK OFF	STOCK OFF	STOCK OFF	STOCK OFF	STOCK OFF
PLAZA LUXURY LIGHT	STOCK OFF	STOCK OFF	STOCK OFF	STOCK OFF	STOCK OFF	STOCK OFF	STOCK OFF	STOCK OFF
PLAZA BOTTICINO BIANCO	STOCK OFF	STOCK OFF	STOCK OFF	STOCK OFF	STOCK OFF	STOCK OFF	STOCK OFF	STOCK OFF
PLAZA BOTTICINO CLASSICO	STOCK OFF	STOCK OFF	STOCK OFF	STOCK OFF	STOCK OFF	STOCK OFF	STOCK OFF	STOCK OFF
ROYALE PÉROLA MATE		STOCK OFF		STOCK OFF		STOCK OFF		STOCK OFF
ROYALE CINZA MATE		STOCK OFF		STOCK OFF		STOCK OFF		STOCK OFF
ROYALE CHOCOLATE MATE	STOCK OFF	STOCK OFF	STOCK OFF	STOCK OFF	STOCK OFF	STOCK OFF	STOCK OFF	STOCK OFF
ROYALE ANTRACITE MATE	STOCK OFF	STOCK OFF	STOCK OFF	STOCK OFF	STOCK OFF	STOCK OFF	STOCK OFF	STOCK OFF



m²

**PLAZA PRÉ-CORTE
MOSAICO LUXURY LIGHT**
22,5X45



m²

**PLAZA PRÉ-CORTE
MOSAICO BOTTICINO BIANCO**
22,5X45



m²

**PLAZA PRÉ-CORTE
MOSAICO BOTTICINO CLASSICO**
22,5X45



m²

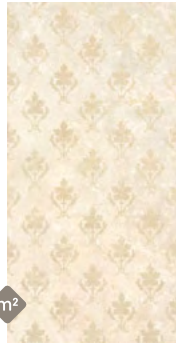

m²

FLEUR-DE-LIS BIANCO
22,5X45

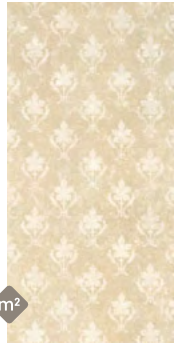

m²

FLEUR-DE-LIS CLASSICO
22,5X45



**BARRA
PLAZA**
6X45



**BARRA
STARS**
6,7X45

STOCK OFF



BARRA INCANTO
5X22,5

STOCK OFF



BARRA INCANTO CLASSICO
5X22,5

STOCK OFF



BARRA PLAZA
6X22,5



BARRA STARS
6,7X22,5

STOCK OFF



BARRA FLEUR-DE-LIS
5X22,5

STOCK OFF



BARRA FLEUR-DE-LIS CLASSICO
5X22,5

STOCK OFF



m²

CUBIC LIGHT
22,5X45

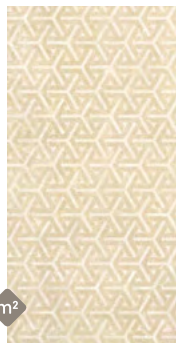

m²

CUBIC BOTTICINO
22,5X45



BLOSSOM LIGHT
22,5X45

STOCK OFF

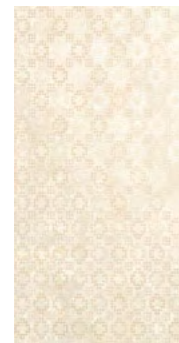

BLOSSOM BIANCO
22,5X45

STOCK OFF

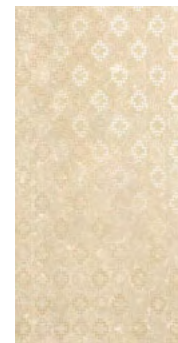

BLOSSOM CLASSICO
22,5X45

STOCK OFF



**LISTELO
STRUCTURE**
3X45

STOCK OFF





Coleção
Collection
Kollektion
Коллекция

ROYALE



REVESTIMENTO COM ACABAMENTO BRILHO
GLOSSY WALL TILES
FAÏANCES AVEC FINITION BRILLANT
WANDFLIESEN - GLÄNZEND OBERFLÄCHE
НАСТЕННАЯ КЕРАМИЧЕСКАЯ ПЛИТКА С ГЛЯНЦЕВЫМ ПОКРЫТИЕМ



35x100 

35x70 

22x45 

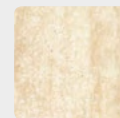

TRAVERTINO
BIANCO

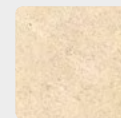

LIPICA BEIGE

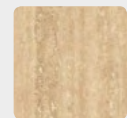

TRAVERTINO
NOCE

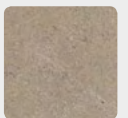

LIPICA GREY

PAVIMENTO COM ACABAMENTO MATE OU SEMI-BRILHO
MATT OR GLOSSY FLOOR TILES
CARREAUX SOL EN FINITION MAT OU SEMI-BRILLANT
BODENFLIESEN - MATT ODER HALBMATT OBERFLÄCHE
НАПОЛЬНАЯ ПЛИТКА С МАТОВЫМ ИЛИ ПОЛУ-ГЛЯНЦЕВЫМ ПОКРЫТИЕМ



45x45 

35x35 

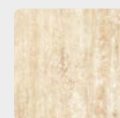

TRAVERTINO
BIANCO

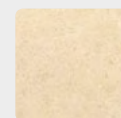

LIPICA BEIGE



TRAVERTINO
NOCE

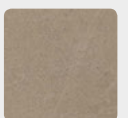

LIPICA GREY

ROYALE





ROYALE



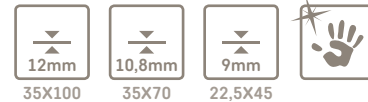

ROYALE TRAVERTINO BIANCO
35X100 RET.
35X70 RET.
22,5X45



ROYALE TRAVERTINO NOCE
35X100 RET.
35X70 RET.
22,5X45

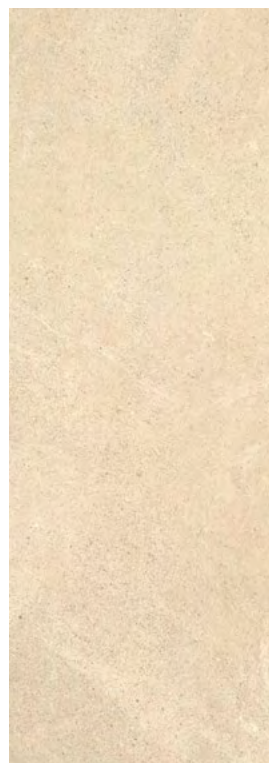

ROYALE LIPICA BEIGE
35X100 RET.
35X70 RET.
22,5X45

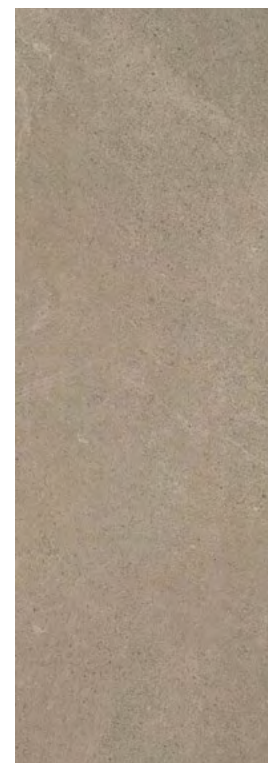

ROYALE LIPICA GREY
35X100 RET.
35X70 RET.
22,5X45

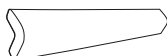

PERFIL ROYALE
1,7X50
1,7X35



ROYALE TRAVERTINO BIANCO
45X45 NAT.
35X35 AMA. RET.

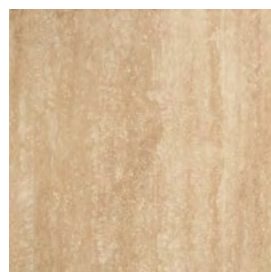

ROYALE TRAVERTINO NOCE
45X45 NAT.
35X35 AMA. RET.

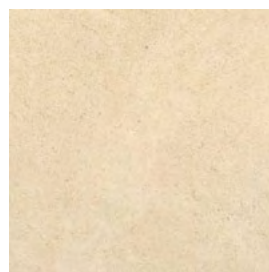

ROYALE LIPICA BEIGE
45X45 NAT.
35X35 AMA. RET.

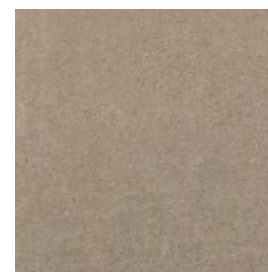

ROYALE LIPICA GREY
45X45 NAT.
35X35 AMA. RET.



TACO SILVER
7,5X7,5



TACO SILVER RELIEF
7,5X7,5



TACO GOLD
7,5X7,5



TACO GOLD RELIEF
7,5X7,5



RODAPÉ ROYALE
8X45



m²

TRAVERTINO SHAPE BIANCO
35X100 RET.



m²

TRAVERTINO SHAPE NOCE
35X100 RET.

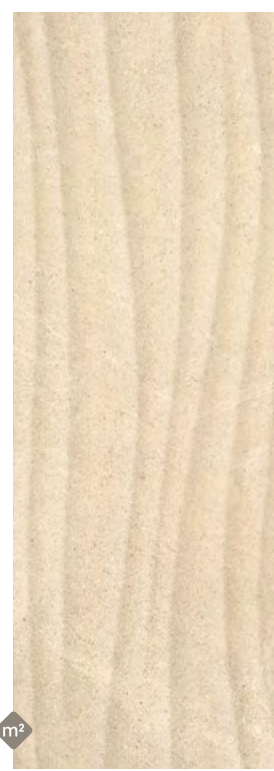

m²

LIPICA SHAPE BEIGE
35X100 RET.



m²

**ROYALE FLOW
TRAVERTINO BIANCO**
35X100 RET.



m²

**ROYALE FLOW
TRAVERTINO NOCE**
35X100 RET.



TRAVERTINO QUANTUM BIANCO
35X100 RET.



TRAVERTINO QUANTUM NOCE
35X100 RET.



LIPICA ANYA BEIGE
35X100 RET.
35X70 RET.



LIPICA ANYA GREY
35X100 RET.
35X70 RET.
STOCK OFF

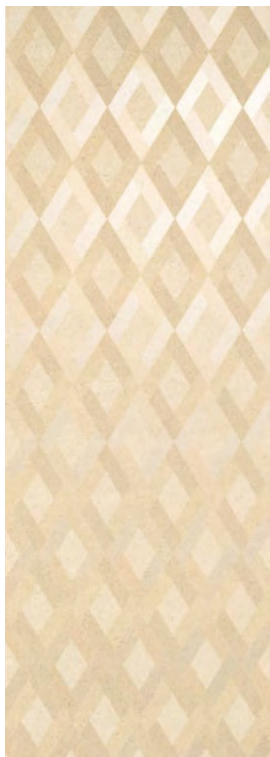

LIPICA FLEX BEIGE
35X100 RET.
35X70 RET.



LIPICA FLEX GREY
35X100 RET.
35X70 RET.



LIPICA ZORA
35X100 RET.
35X70 RET.

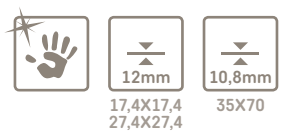

TRAVERTINO QUANTUM BIANCO
35X70 RET.



TRAVERTINO QUANTUM NOCE
35X70 RET.



LIPICA QUANTUM BEIGE
35X70 RET.



LIPICA QUANTUM GREY
35X70 RET.

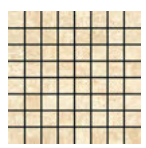

MOSAICO ROYALE TRAVERTINO BIANCO
17,4X17,4 (1,9X1,9)

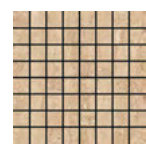

MOSAICO ROYALE TRAVERTINO NOCE
17,4X17,4 (1,9X1,9)

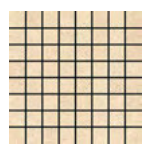

MOSAICO ROYALE LIPICA BEIGE
17,4X17,4 (1,9X1,9)

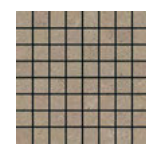

MOSAICO ROYALE LIPICA GREY
17,4X17,4 (1,9X1,9)

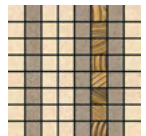

MOSAICO ROYALE DECOR A
17,4X17,4 (1,9X1,9)



MOSAICO ROYALE DECOR B
17,4X17,4 (1,9X1,9)

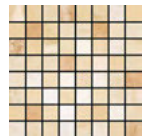

MOSAICO ROYALE DECOR C
17,4X17,4 (1,9X1,9)

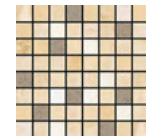

MOSAICO ROYALE DECOR D
17,4X17,4 (1,9X1,9)

STOCK OFF



MOSAICO GOLD MIX
27,4X27,4 (3,3X3,3)



MOSAICO SILVER MIX
27,4X27,4 (3,3X3,3)



LISTELO ARGENTO
4X35
STOCK OFF



LISTELO ORO
1,5X35



LISTELO ORO
1X100



TRAVERTINO ROMBI BIANCO
22,5X45

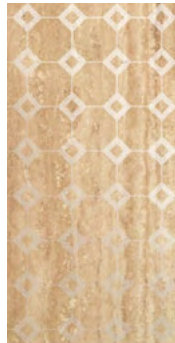

TRAVERTINO ROMBI NOCE
22,5X45



LIPICA HONEY BEIGE
22,5X45



LIPICA HONEY GREY
22,5X45



ROYALE PRÉ-CORTE MOSAICO DECOR E
22,5X45



ROYALE PRÉ-CORTE MOSAICO DECOR F
22,5X45



LISTELO NOBEL BEIGE
2X45



LISTELO NOBEL GREY
2X45



LISTELO STRUCTURE
3X45
STOCK OFF



BARRA PALACE
6,5X45



BARRA ROYALE BEIGE
5X22,5



BARRA ROYALE GREY
5X22,5



BARRA RINGS
5,8X22,5



PEÇAS ESPECIAIS - SPECIAL PIECES - PIÈCES SPÉCIALES - SPEZIALTEILE - СПЕЦИАЛЬНЫЕ ДЕКОРАТИВНЫЕ ЭЛЕМЕНТЫ



CAPITELLO
10X35



ANGOLO CAPITELLO
10X5



MATITA
2X35



ANGOLO MATITA
2X2



TORELLO
4X35



ANGOLO TORELLO
4X2



ALZATA
15X35



ANGOLO ALZATA
5X15

ROYALE PÉROLA MATE	STOCK OFF	STOCK OFF	STOCK OFF	STOCK OFF	STOCK OFF	STOCK OFF	STOCK OFF
ROYALE CINZA MATE	STOCK OFF	STOCK OFF	STOCK OFF	STOCK OFF	STOCK OFF	STOCK OFF	STOCK OFF
ROYALE CHOCOLATE MATE	STOCK OFF	STOCK OFF	STOCK OFF	STOCK OFF	STOCK OFF	STOCK OFF	STOCK OFF
ROYALE ANTRACITE MATE	STOCK OFF	STOCK OFF	STOCK OFF	STOCK OFF	STOCK OFF	STOCK OFF	STOCK OFF



ATELIER



REVESTIMENTO COM ACABAMENTO BRILHO
GLOSSY WALL TILES
FAÏANCES AVEC FINITION BRILLANT
WANDFLIESEN - GLÄNZEND OBERFLÄCHE
НАСТЕННАЯ КЕРАМИЧЕСКАЯ ПЛИТКА С ГЛЯНЦЕВЫМ ПОКРЫТИЕМ



REVESTIMENTO COM ACABAMENTO MATE OU SEMI-BRILHO
MATT OR SEMI-GLOSS WALL TILES
FAÏANCES EN FINITION MAT OU SEMI-BRILLANT
WANDFLIESEN - MATT ODER HALBMATT OBERFLÄCHE
НАСТЕННАЯ КЕРАМИЧЕСКАЯ ПЛИТКА С МАТОВЫМ ИЛИ ПОЛУ-ГЛЯНЦЕВЫМ ПОКРЫТИЕМ



35x100 

22x45 

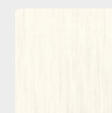

DIAMANT
BLANC

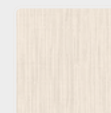

ALPIN
CRÈME

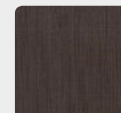

DRAPEAU
MARRON

PAVIMENTO COM ACABAMENTO MATE OU SEMI-BRILHO
MATT OR GLOSSY FLOOR TILES
CARREAUX SOL EN FINITION MAT OU SEMI-BRILLANT
BODENFLIESEN - MATT ODER HALBMATT OBERFLÄCHE
НАПОЛЬНАЯ ПЛИТКА С МАТОВЫМ ИЛИ ПОЛУ-ГЛЯНЦЕВЫМ ПОКРЫТИЕМ



45x45 

35x35 

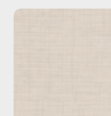

ZIGZAG
CRÈME

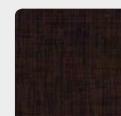

ÉPINEUX
MARRON

XXXX
XXXX
XXXX

ATELIER







✕ **ATELIER DIAMANT BLANC**
 35X100 RET.
 22,5X45
ATELIER DIAMANT BLANC SATIN
 35X100 RET.
 22,5X45



✕ **ATELIER ALPIN CRÈME**
 35X100 RET.
 22,5X45
ATELIER ALPIN CRÈME SATIN
 35X100 RET.
 22,5X45



✕ **ATELIER DRAPEAU MARRON**
 35X100 RET.
 22,5X45
ATELIER DRAPEAU MARRON SATIN
 35X100 RET.
 22,5X45

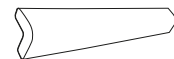

PERFIL ATELIER
 1,7X50

PERFIL ATELIER SATIN
 1,7X50



ATELIER ZIGZAG CRÈME
 45X45

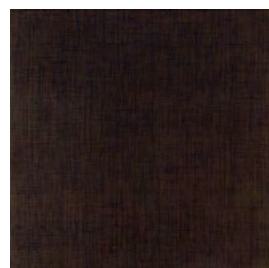

ATELIER ÉPINEUX MARRON
 45X45



RODAPÉ ATELIER
 8X45



ÉTOILE BLANC SATIN
35X100 RET.
STOCK OFF



ÉTOILE MARRON SATIN
35X100 RET.



FEUILLAGE RELIEF
35X100 RET.
STOCK OFF



BARRA
FEUILLAGE RELIEF
11X100 RET.
STOCK OFF



PAILLETES
35X100 RET.
STOCK OFF



RAMURE SATIN
35X100 RET.



ZÈBRÉ SATIN
35X100 RET.
STOCK OFF

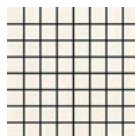

MOSAICO
ATELIER BLANC
17,4X17,4 (1,9X1,9)

STOCK OFF

MOSAICO ATELIER
BLANC SATIN
17,4X17,4 (1,9X1,9)

STOCK OFF



TIRAS
ATELIER BLANC
17,4X17,4 (1,1X17,4)

STOCK OFF

TIRAS ATELIER
BLANC SATIN
17,4X17,4 (1,1X17,4)

STOCK OFF

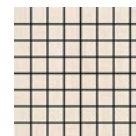

MOSAICO
ATELIER CRÈME
17,4X17,4 (1,9X1,9)

STOCK OFF

MOSAICO ATELIER
CRÈME SATIN
17,4X17,4 (1,9X1,9)

STOCK OFF

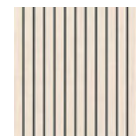

TIRAS
ATELIER CRÈME
17,4X17,4 (1,1X17,4)

STOCK OFF

TIRAS ATELIER
CRÈME SATIN
17,4X17,4 (1,1X17,4)

STOCK OFF



MOSAICO
ATELIER MARRON
17,4X17,4 (1,9X1,9)

STOCK OFF

MOSAICO ATELIER
MARRON SATIN
17,4X17,4 (1,9X1,9)

STOCK OFF

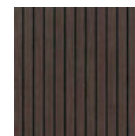

TIRAS
ATELIER MARRON
17,4X17,4 (1,1X17,4)

STOCK OFF

TIRAS ATELIER
MARRON SATIN
17,4X17,4 (1,1X17,4)

STOCK OFF



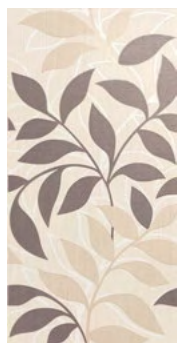

FEUILLES SATIN
22,5X45



ÉDEN SATIN
22,5X45



CASCADE BLANC A
22,5X45



CASCADE BLANC B
22,5X45
LISTELO CASCADE BLANC
4X45



MARGUERITE BLANC A
22,5X45



MARGUERITE BLANC B
22,5X45



OVALINE CRÈME
22,5X45



OVALINE BEIGE
22,5X45
STOCK OFF



OVALINE MARRON
22,5X45



FLEUR BLANC
22,5X45



BARRA
BRODERIE SATIN
5X45



BARRA OVALINE MARRON
7X45



LISTELO FLEUR BLANC
4X45



BARRA CORDONÉ
5X45



LISTELO LINEA
3X22,5



PEÇAS ESPECIAIS · SPECIAL PIECES · PIÈCES SPÉCIALES · SPEZIALTEILE · СПЕЦИАЛЬНЫЕ ДЕКОРАТИВНЫЕ ЭЛЕМЕНТЫ

	ATELIER DIAMANT BLANC · ATELIER DIAMANT BLANC SATIN
	ATELIER ALPIN CRÈME · ATELIER ALPIN CRÈME SATIN
	ATELIER DRAPEAU MARRON · ATELIER DRAPEAU MARRON



MATITA
2X35

STOCK OFF



ANGOLO
MATITA
2X2

STOCK OFF



TORELLO
4X35

STOCK OFF



ANGOLO
TORELLO
2X4

STOCK OFF

STOCK OFF

STOCK OFF

STOCK OFF

STOCK OFF

STOCK OFF

STOCK OFF

STOCK OFF

STOCK OFF



Coleção
Collection
Kollektion
Коллекция

DREAMS



REVESTIMENTO COM ACABAMENTO BRILHO
GLOSSY WALL TILES
FAIANÇAS AVEC FINITION BRILLANT
WANDFLIESEN - GLÄNZEND OBERFLÄCHE
НАСТЕННАЯ КЕРАМИЧЕСКАЯ ПЛИТКА С ГЛЯНЦЕВЫМ ПОКРЫТИЕМ



35x100



22x45



NEVE



PÉROLA



CINZA

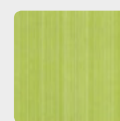

GREEN

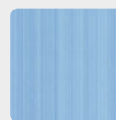

CIELO



LARANJA

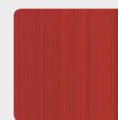

CEREJA



CHOCOLATE





DREAMS CIELO 35X100 RET. || DREAMS NEVE 35X100 RET. || TIRAS DREAMS DECOR B 17,4X17,4 || TIRAS DREAMS NEVE 17,4X17,4

XXXX DREAMS





DREAMS NEVE
35X100 RET.
22,5X45



DREAMS PÉROLA
35X100 RET.
22,5X45



DREAMS CINZA
35X100 RET.
22,5X45



DREAMS GREEN
35X100 RET.
22,5X45

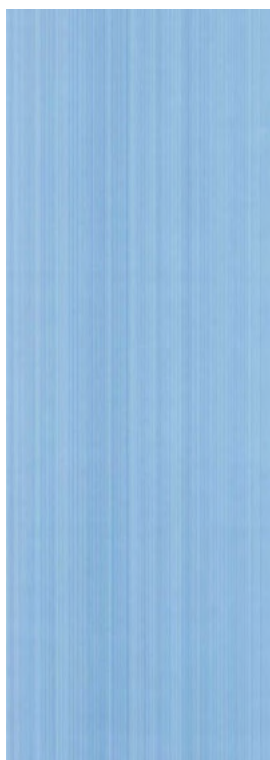

DREAMS CIELO
35X100 RET.
22,5X45



DREAMS LARANJA
35X100 RET.
22,5X45



DREAMS CEREJA
35X100 RET.
22,5X45



DREAMS CHOCOLATE
35X100 RET.
22,5X45

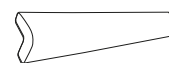

PERFIL DREAMS
1,7X50
1,7X35

DREAMS



ROSEN CIELO
70X100 RET.
STOCK OFF

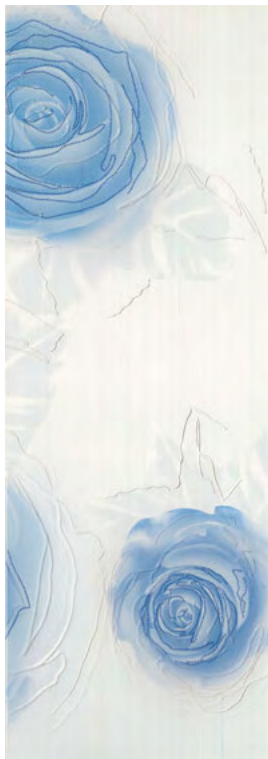

BARRA BLOOM NEVE
10X100 RET.
STOCK OFF



BARRA BLOOM CINZA
10X100 RET.
STOCK OFF



BARRA BLOOM PÉROLA
10X100 RET.
STOCK OFF



BARRA BLOOM GREEN
10X100 RET.
STOCK OFF



ROSEN CEREJA
70X100 RET.
STOCK OFF

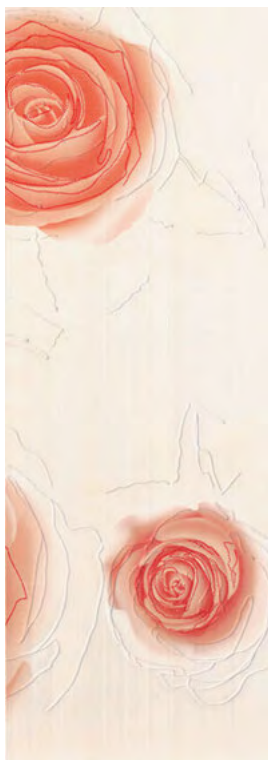

BARRA BLOOM CIELO
10X100 RET.
STOCK OFF



BARRA BLOOM LARANJA
10X100 RET.
STOCK OFF



BARRA BLOOM CEREJA
10X100 RET.
STOCK OFF



BARRA BLOOM CHOCOLATE
10X100 RET.
STOCK OFF



EXAGON NEVE
35X100 RET.
STOCK OFF

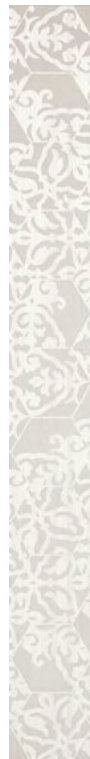

BARRA EXAGON NEVE
11X100 RET.

STOCK OFF



EXAGON PÉROLA
35X100 RET.
STOCK OFF

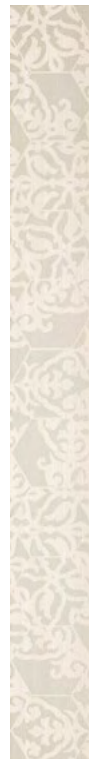

BARRA EXAGON PÉROLA
11X100 RET.

STOCK OFF



DYNAMIC CHOCOLATE
35X100 RET.
STOCK OFF



WALL PAPER NEUTRO
35X100 RET.



WALL PAPER GREEN
35X100 RET.



WALL PAPER CIELO
35X100 RET.



LISTELO GEOMETRICO AZUL
4,7X35
STOCK OFF



LISTELO NACAR AZUL
4,7X35



LISTELO GEOMETRICO VERMELHO
4,7X35
STOCK OFF



LISTELO NACAR LARANJA
4,7X35



LISTELO TRIM CIELO
7X35
STOCK OFF



LISTELO TRIM CEREJA
7X35
STOCK OFF

DREAMS

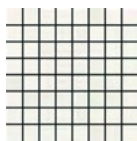

✕ MOSAICO DREAMS NEVE
17,4X17,4 (1,9X1,9)

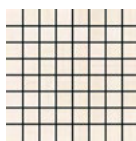

✕ MOSAICO DREAMS PÉROLA
17,4X17,4 (1,9X1,9)

STOCK OFF

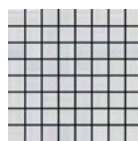

✕ MOSAICO DREAMS CINZA
17,4X17,4 (1,9X1,9)

STOCK OFF

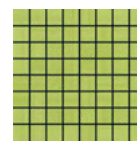

✕ MOSAICO DREAMS GREEN
17,4X17,4 (1,9X1,9)

STOCK OFF

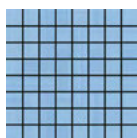

✕ MOSAICO DREAMS CIELO
17,4X17,4 (1,9X1,9)

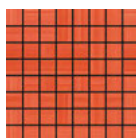

✕ MOSAICO DREAMS LARANJA
17,4X17,4 (1,9X1,9)



✕ MOSAICO DREAMS CEREJA
17,4X17,4 (1,9X1,9)



✕ MOSAICO DREAMS CHOCOLATE
17,4X17,4 (1,9X1,9)

STOCK OFF

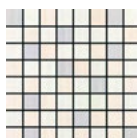

✕ MOSAICO DREAMS DECOR A
17,4X17,4 (1,9X1,9)

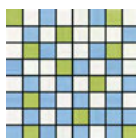

✕ MOSAICO DREAMS DECOR B
17,4X17,4 (1,9X1,9)

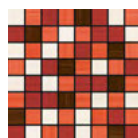

✕ MOSAICO DREAMS DECOR C
17,4X17,4 (1,9X1,9)



✕ TIRAS DREAMS NEVE
17,4X17,4 (1,1X17,4)



✕ TIRAS DREAMS PÉROLA
17,4X17,4 (1,1X17,4)



✕ TIRAS DREAMS CINZA
17,4X17,4 (1,1X17,4)

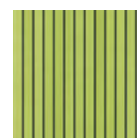

✕ TIRAS DREAMS GREEN
17,4X17,4 (1,1X17,4)

STOCK OFF

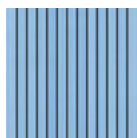

✕ TIRAS DREAMS CIELO
17,4X17,4 (1,1X17,4)

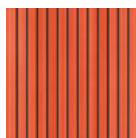

✕ TIRAS DREAMS LARANJA
17,4X17,4 (1,1X17,4)



✕ TIRAS DREAMS CEREJA
17,4X17,4 (1,1X17,4)



✕ TIRAS DREAMS CHOCOLATE
17,4X17,4 (1,1X17,4)

STOCK OFF



✕ TIRAS DREAMS DECOR A
17,4X17,4 (1,1X17,4)

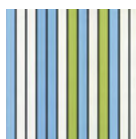

✕ TIRAS DREAMS DECOR B
17,4X17,4 (1,1X17,4)



✕ TIRAS DREAMS DECOR C
17,4X17,4 (1,1X17,4)

STOCK OFF

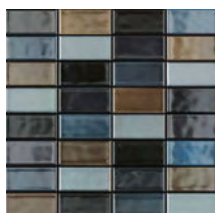

MOSAICO DECOR TREND
27,4X27,9 (3,3X6,9)



BIJOU NEVE
22,5X45
STOCK OFF

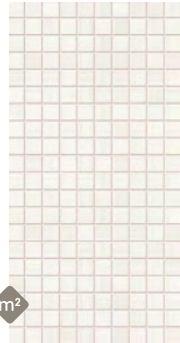

**DREAMS PRÉ-CORTE
MOSAICO NEVE**
22,5X45



CIRCUIT CHOCOLATE
22,5X45
STOCK OFF

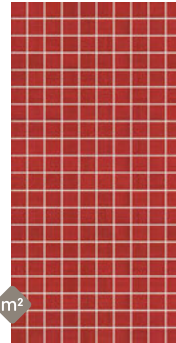

**DREAMS PRÉ-CORTE
MOSAICO CEREJA**
22,5X45

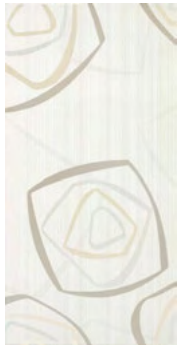

POLIGONI NEVE
45X45



POLIGONI CEREJA
45X45



POLIGONI GREEN
45X45



BARRA HAPPY FLOWER CIELO A
11X45



BARRA HAPPY FLOWER CEREJA A
11X45



BARRA HAPPY FLOWER GREEN A
11X45



BARRA HAPPY FLOWER CIELO B
11X45
STOCK OFF



BARRA HAPPY FLOWER CEREJA B
11X45



BARRA HAPPY FLOWER GREEN B
11X45



LISTELO SKY BLUE
7X22,5



LISTELO AUTUMN CHOCOLATE
7X22,5
STOCK OFF

PEÇAS ESPECIAIS - SPECIAL PIECES - PIÈCES SPÉCIALES · SPEZIALTEILE - СПЕЦИАЛЬНЫЕ ДЕКОРАТИВНЫЕ ЭЛЕМЕНТЫ



MATITA
2X35



ANGOLO MATITA
2X2



TORELLO
4X35



ANGOLO TORELLO
2X4



DREAMS NEVE
DREAMS PÉROLA
DREAMS CINZA
DREAMS GREEN
DREAMS CIELO
DREAMS LARANJA
DREAMS CEREJA
DREAMS CHOCOLATE

STOCK OFF

STOCK OFF

STOCK OFF

STOCK OFF

STOCK OFF

STOCK OFF

STOCK OFF

STOCK OFF

STOCK OFF

STOCK OFF

STOCK OFF

STOCK OFF

STOCK OFF

STOCK OFF

STOCK OFF

STOCK OFF

STOCK OFF

STOCK OFF

STOCK OFF

STOCK OFF

STOCK OFF

STOCK OFF

STOCK OFF

STOCK OFF

STOCK OFF

STOCK OFF

STOCK OFF

STOCK OFF

STOCK OFF

STOCK OFF

STOCK OFF

STOCK OFF



LIGHT



REVESTIMENTO COM ACABAMENTO BRILHO
GLOSSY WALL TILES
FAÏANCES AVEC FINITION BRILLANT
WANDFLIESEN - GLÄNZEND OBERFLÄCHE
НАСТЕННАЯ КЕРАМИЧЕСКАЯ ПЛИТКА С ГЛЯНЦЕВЫМ ПОКРЫТИЕМ



REVESTIMENTO COM ACABAMENTO MATE OU SEMI-BRILHO
MATT OR SEMI-GLOSS WALL TILES
FAÏANCES EN FINITION MAT OU SEMI-BRILLANT
WANDFLIESEN - MATT ODER HALBMATT OBERFLÄCHE
НАСТЕННАЯ КЕРАМИЧЕСКАЯ ПЛИТКА С МАТОВЫМ ИЛИ ПОЛУ-ГЛЯНЦЕВЫМ ПОКРЫТИЕМ



35x100 12mm

35x70 10,8mm

30x60 10mm

22x45 9mm

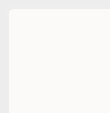

BRANCO
BRILHO

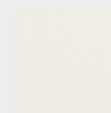

MATT WHITE

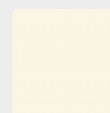

PÉROLA
BRILHO

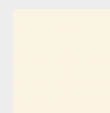

PÉROLA
MATE

PAVIMENTO COM ACABAMENTO MATE OU SEMI-BRILHO
MATT OR GLOSSY FLOOR TILES
CARREAUX SOL EN FINITION MAT OU SEMI-BRILLANT
BODENFLIESEN - MATT ODER HALBMATT OBERFLÄCHE
НАПОЛЬНАЯ ПЛИТКА С МАТОВЫМ ИЛИ ПОЛУ-ГЛЯНЦЕВЫМ ПОКРЫТИЕМ



60x60 10mm

30x60 10mm

35x35 9mm

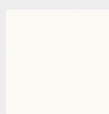

BRANCO
BRILHO

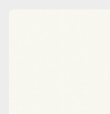

BRANCO
MATE

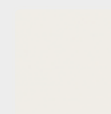

MATT WHITE

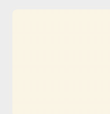

PÉROLA
BRILHO

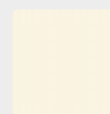

PÉROLA
MATE

XXXX LIGHT





LIGHT BRANCO BRILHO 35X100 RET. || MOSAICO SILVER MIX 27,4X27,4

XXXX LIGHT



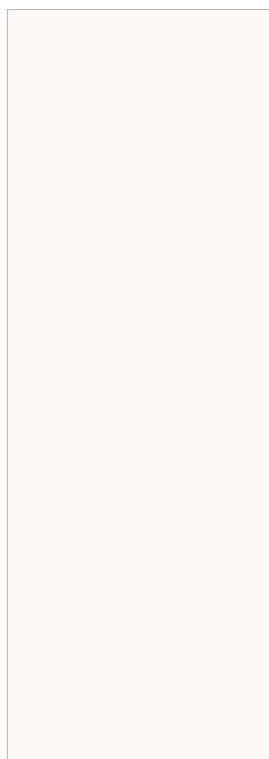
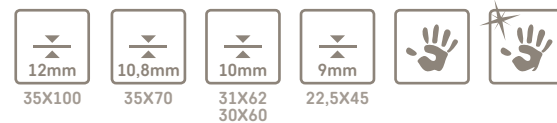

✕ **LIGHT BRANCO BRILHO**
35X100 RET.
35X70 RET.
31X62
30X60 RET.
22,5X45

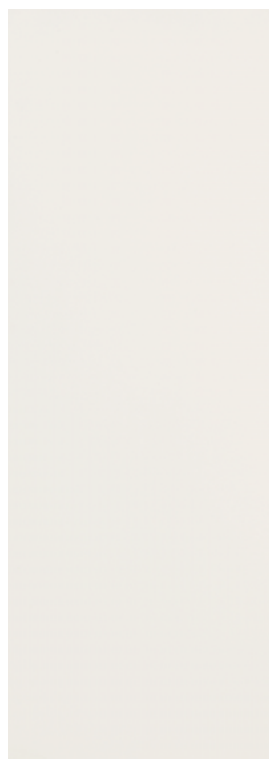

LIGHT MATT WHITE
35X100 RET.
35X70 RET.
31X62
30X60 RET.
22,5X45

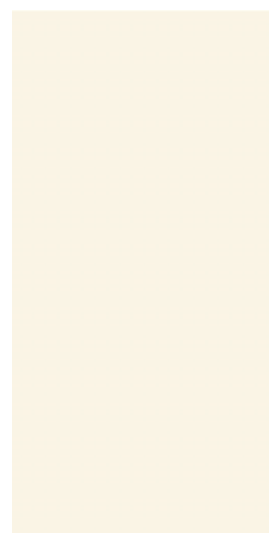

✕ **LIGHT PÉROLA BRILHO**
35X70 RET.
22,5X45

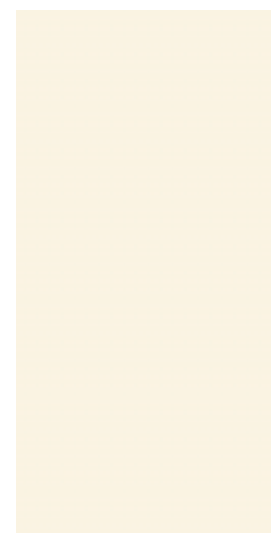

LIGHT PÉROLA MATE
35X70 RET.
22,5X45

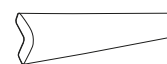

PERFIL LIGHT
1,7X50
1,7X35

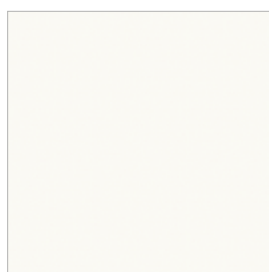

LIGHT BRANCO BRILHO
35X35 RET.

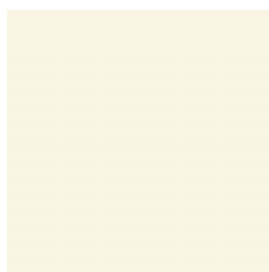

LIGHT PÉROLA BRILHO
35X35 RET.

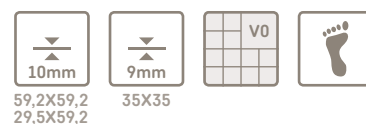

59,2X59,2
29,5X59,2

35X35

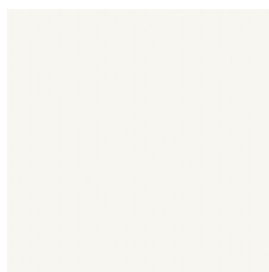

LIGHT BRANCO MATE
35X35 RET.

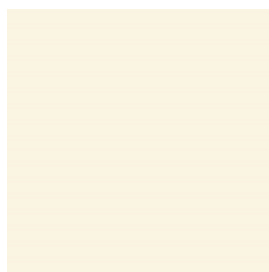

LIGHT PÉROLA MATE
35X35 RET.

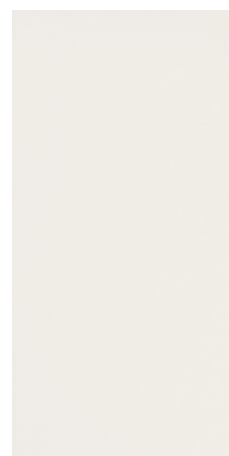

LIGHT MATT WHITE
29,5X59,2 RET.

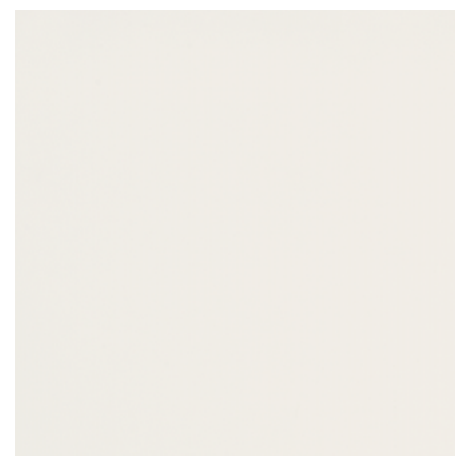

LIGHT MATT WHITE
59,2X59,2 RET.

xxx
xxx
xxx

LIGHT



35X100



35X70



22,5X45



✕ VIBRATO BRANCO BRILHO
35X100 RET.
STOCK OFF



✕ BARRA ALLEGRETTO BRILHO
11,6X100 RET.
STOCK OFF



✕ BARRA GLISSANDO BRILHO
11,6X100 RET.
STOCK OFF

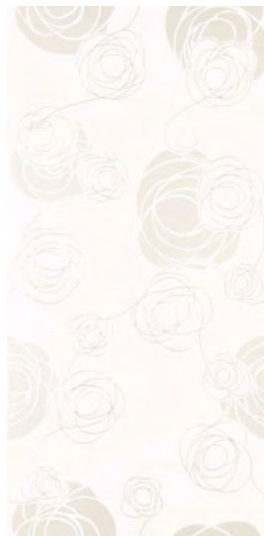

✕ SINFONIA BRANCO BRILHO
35X70 RET.
STOCK OFF



✕ BARRA SINFONIA BRANCO BRILHO
8,3X70 RET.
STOCK OFF



m²
GOLD MIRAGE
22,5X45



✕ VIBRATO BRANCO BRILHO
35X70 RET.
STOCK OFF



✕ BARRA SONATA BRANCO BRILHO
8,3X70 RET.
STOCK OFF



✕ BARRA MINUETTO BRANCO BRILHO
8,3X70 RET.
STOCK OFF

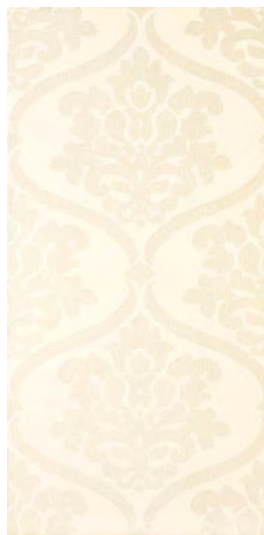

VIBRATO PÉROLA MATE
35X70 RET.
STOCK OFF



BARRA SONATA PÉROLA MATE
8,3X70 RET.
STOCK OFF



✕ **MOSAICO GOLD MIX**
27,4X27,4 (3,3X3,3)



✕ **MOSAICO SILVER MIX**
27,4X27,4 (3,3X3,3)



MOSAICO DECOR TREND
27,4X27,9 (3,3X6,9)



BARRA INOX BRILHO
2X100



BARRA INOX BRILHO
1X100



BARRA INOX ESCOVADA
0,6X300



BARRA INOX ESCOVADA
1X300



BARRA INOX POLIDA
1,5X300



CALHA AÇO INOX ESMERILADA
1X250 (1X1,3X250)
STOCK OFF



Coleção
Collection
Kollektion
Коллекция

LOFT



REVESTIMENTO ESTRUTURADO COM ACABAMENTO MATE OU SEMI-BRILHO
MATT OR GLOSSY STRUCTURED WALL TILES
FAIANÇAS STRUCTURÉ EN FINITION MAT OU SEMI-BRILLANT
STRUKTURIERTE WANDFLIESEN - MATT ODER HALBMATT OBERFLÄCHE
НАСТЕННАЯ СТРУКТУРИРОВАННАЯ ПЛИТКА С МАТОВЫМ ИЛИ ПОЛУ-ГЛЯНЦЕВЫМ ПОКРЫТИЕМ



30x60

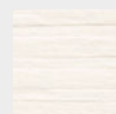

WHITE

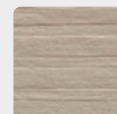

TORTORA

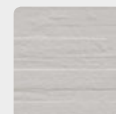

LIGHT GREY

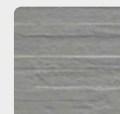

GREY











LOFT



LOFT WHITE
30X60 RET.
31X62

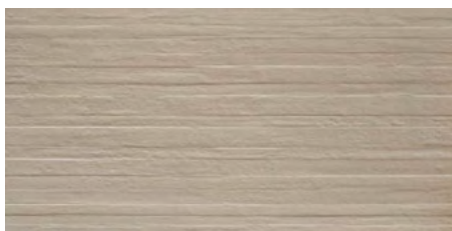

LOFT TORTORA
30X60 RET.
31X62



LOFT LIGHT GREY
30X60 RET.
31X62



LOFT GREY
30X60 RET.
31X62

BARRA INOX ESCOVADA
1X300

BARRA INOX POLIDA
1,5X300



PAVIMENTOS COORDENADOS
 COORDINATED FLOOR TILES
 SOLS COORDONNÉS
 KOORDINIERTE BODEN FLIESEN
 КООРДИНИРОВАННАЯ НАПОЛЬНАЯ ПЛИТКА





EMMA



REVESTIMENTO COM ACABAMENTO MATE OU SEMI-BRILHO
MATT OR SEMI-GLOSS WALL TILES
FAÏANCES EN FINITION MAT OU SEMI-BRILLANT
WANDFLIESEN - MATT ODER HALBMATT OBERFLÄCHE
НАСТЕННАЯ КЕРАМИЧЕСКАЯ ПЛИТКА С МАТОВЫМ ИЛИ ПОЛУ-ГЛЯНЦЕВЫМ ПОКРЫТИЕМ



30x60

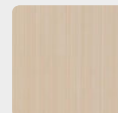

CREAM



COOKIES

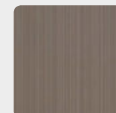

MOCHA



BUBBLE GUM

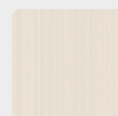

COCONUT

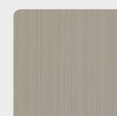

EARL GREY

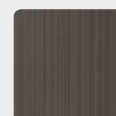

BLACK SESAME



MINT

PAVIMENTO COM ACABAMENTO MATE OU SEMI-BRILHO
MATT OR GLOSSY FLOOR TILES
CARREAUX SOL EN FINITION MAT OU SEMI-BRILLANT
BODENFLIESEN - MATT ODER HALBMATT OBERFLÄCHE
НАПОЛЬНАЯ ПЛИТКА С МАТОВЫМ ИЛИ ПОЛУ-ГЛЯНЦЕВЫМ ПОКРЫТИЕМ



45x45



CREAM



COOKIES

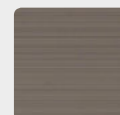

MOCHA

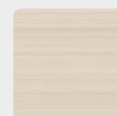

COCONUT

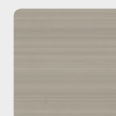

EARL GREY

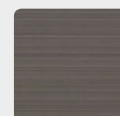

BLACK SESAME





EMMA COCONUT 30X60 RET. || BUBBLE GUM 30X60 RET. || BUBBLE GUM FROZEN YOGURT 30X60 RET. || EMMA COCONUT 44X44 RET.

EMMA





EMMA COCONUT 30X60 RET. || BLACK SESAME 30X60 RET. || MOSAIC ICE CRUNCH 30X30 || BARRA INOX ESCOVADA 1X300 || EMMA BLACK SESAME 44X44 RET.



EMMA



EMMA CREAM
31X62
30X60 RET.



EMMA COOKIES
31X62
30X60 RET.



EMMA MOCHA
31X62
30X60 RET.



EMMA BUBBLE GUM
31X62
30X60 RET.



EMMA CREAM
45X45
44X44 RET.

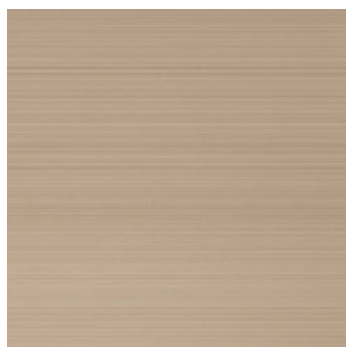

EMMA COOKIES
45X45
44X44 RET.



EMMA MOCHA
45X45
44X44 RET.



EMMA COCONUT
31X62
30X60 RET.



EMMA EARL GREY
31X62
30X60 RET.

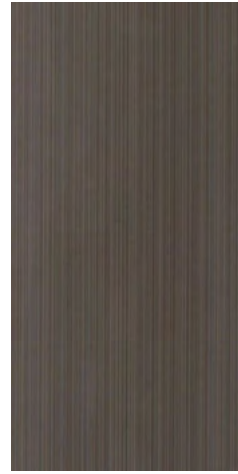

EMMA BLACK SESAME
31X62
30X60 RET.

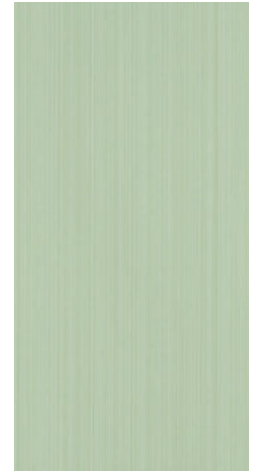

EMMA MINT
31X62
30X60 RET.



PERFIL EMMA
VERTICAL
1,7X30

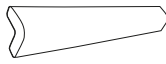

PERFIL EMMA
HORIZONTAL
1,7X30



EMMA COCONUT
45X45
44X44 RET.



EMMA EARL GREY
45X45
44X44 RET.

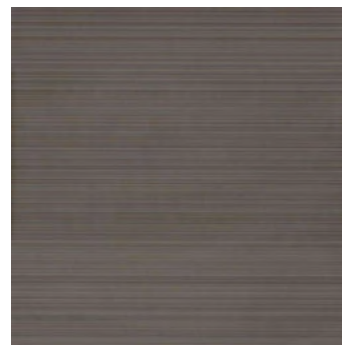

EMMA BLACK SESAME
45X45
44X44 RET.

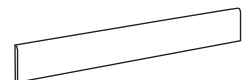

RODAPÉ EMMA
8X45



EMMA



BUBBLE GUM SUNDAE
30X60 RET.



MINT SUNDAE
30X60 RET.

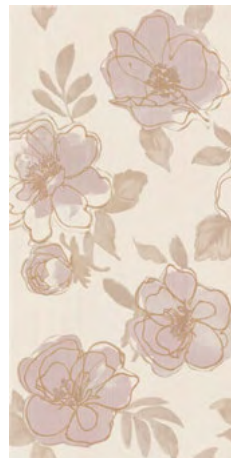

BUBBLE GUM FROZEN YOGURT
30X60 RET.

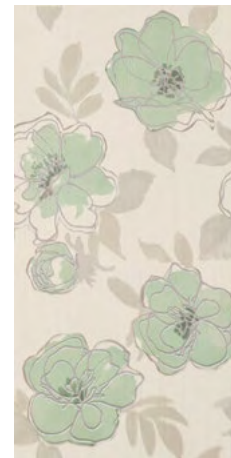

MINT FROZEN YOGURT
30X60 RET.



BUBBLE GUM GLAZE
31X62
30X60 RET.



MINT GLAZE
31X62
30X60 RET.



ICE GLAZE
31X62
30X60 RET.



HOT GLAZE
31X62
30X60 RET.



EARL GREY MILKSHAKE
30X60 RET.



COOKIES N' CREAM MILKSHAKE
30X60 RET.



ICE SORBET
31X62
30X60 RET.

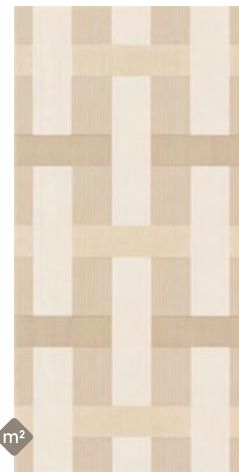

HOT SORBET
31X62
30X60 RET.

BARRA INOX ESCOVADA
1X300

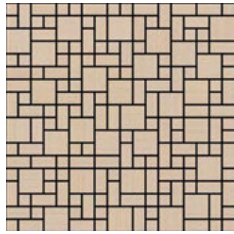

MOSAIC CREAM CRUNCH
30X30

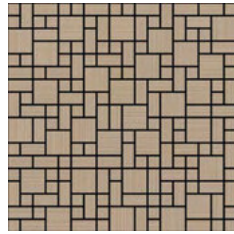

MOSAIC COOKIES CRUNCH
30X30

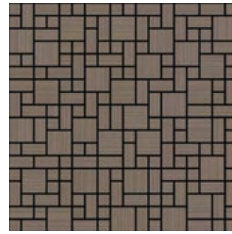

MOSAIC MOCHA CRUNCH
30X30
STOCK OFF



MOSAIC HOT CRUNCH
30X30



MOSAIC HOT SMOOTHIE
24X24

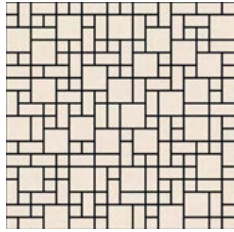

MOSAIC COCONUT CRUNCH
30X30



MOSAIC EARL GREY CRUNCH
30X30



MOSAIC BLACK SESAME CRUNCH
30X30
STOCK OFF



MOSAIC ICE CRUNCH
30X30



MOSAIC ICE SMOOTHIE
24X24

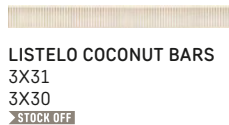

LISTELO COCONUT BARS
3X31
3X30
STOCK OFF

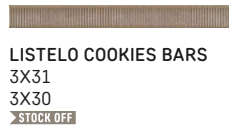

LISTELO COOKIES BARS
3X31
3X30
STOCK OFF



LISTELO EARL GREY BARS
3X31
3X30
STOCK OFF

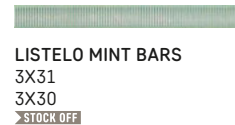

LISTELO MINT BARS
3X31
3X30
STOCK OFF

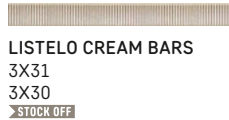

LISTELO CREAM BARS
3X31
3X30
STOCK OFF

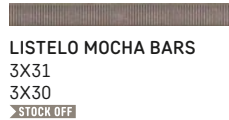

LISTELO MOCHA BARS
3X31
3X30
STOCK OFF

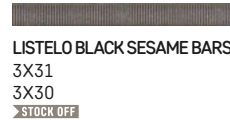

LISTELO BLACK SESAME BARS
3X31
3X30
STOCK OFF

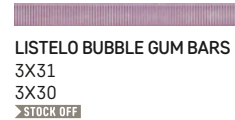

LISTELO BUBBLE GUM BARS
3X31
3X30
STOCK OFF



BARRA COCONUT CHIPS
3,5X60



BARRA EARL GREY CHIPS
3,5X60



BARRA BLACK SESAME CHIPS
3,5X60



BARRA CREAM CROMBS
3,5X60
STOCK OFF



BARRA COOKIES CROMBS
3,5X60
STOCK OFF



BARRA MOCHA CROMBS
3,5X60
STOCK OFF



LISTELO COCONUT BARS
3X60
3X62
STOCK OFF



LISTELO CREAM BARS
3X60
3X62
STOCK OFF



LISTELO COOKIES BARS
3X60
3X62
STOCK OFF



LISTELO MOCHA BARS
3X60
3X62
STOCK OFF



LISTELO EARL GREY BARS
3X60
3X62
STOCK OFF



LISTELO BLACK SESAME BARS
3X60
3X62
STOCK OFF



LISTELO MINT BARS
3X60
3X62
STOCK OFF



LISTELO BUBBLE GUM BARS
3X60
3X62
STOCK OFF





Coleção
Collection
Kollektion
Коллекция

GROUND



REVESTIMENTO COM ACABAMENTO MATE OU SEMI-BRILHO
MATT OR SEMI-GLOSS WALL TILES
FAIÂNCES EN FINITION MAT OU SEMI-BRILLANT
WANDFLIESEN - MATT ODER HALBMATT OBERFLÄCHE
НАСТЕННАЯ КЕРАМИЧЕСКАЯ ПЛИТКА С МАТОВЫМ ИЛИ ПОЛУ-ГЛЯНЦЕВЫМ ПОКРЫТИЕМ



20x60

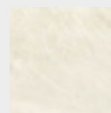

WHITE

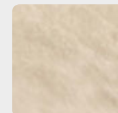

CREAM

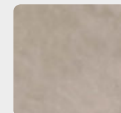

TORTORA

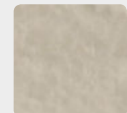

LIGHT GREY

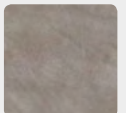

GREY

PAVIMENTO E REVESTIMENTO
FLOOR AND WALL TILES
FAIENCES ET CARREAUX SOL
WANDFLIESEN UND BODENFLIESEN
ПЛИТКА ОБЛИЦОВОЧНАЯ И НАПОЛЬНАЯ



60x60



30x60



45x45

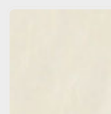

WHITE

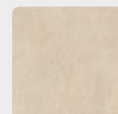

CREAM

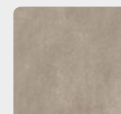

TORTORA

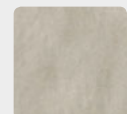

LIGHT GREY

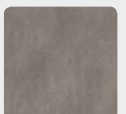

GREY

XXXX
XXXX
XXXX
XXXX
GROUND





XXXX
XXXX
XXXX
XXXX

GROUND





GROUND TORTORA 20X60 || MOSAIC GROUND CREAM 20X20

XXXX
XXXX
XXXX

GROUND









GROUND



GROUND WHITE
20X60

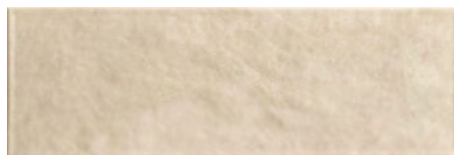

GROUND CREAM
20X60

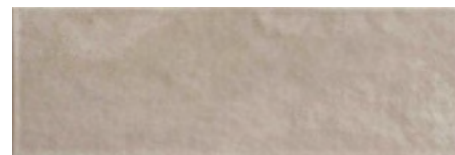

GROUND TORTORA
20X60

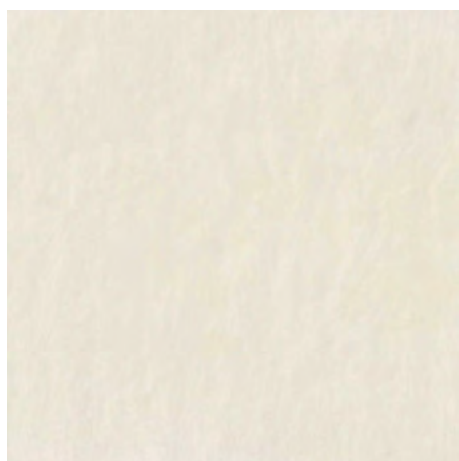
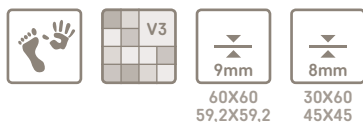

GROUND WHITE
60X60
59,2X59,2 RET.
45X45



GROUND CREAM
60X60
59,2X59,2 RET.
45X45

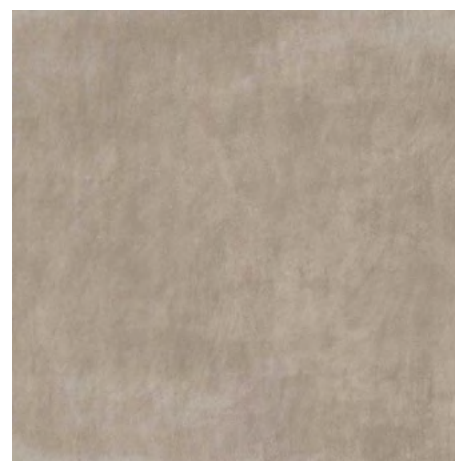

GROUND TORTORA
60X60
59,2X59,2 RET.
45X45

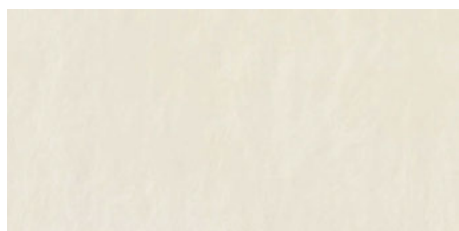

GROUND WHITE
30X60

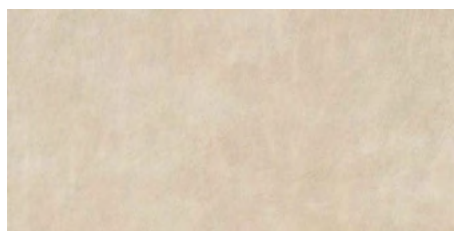

GROUND CREAM
30X60

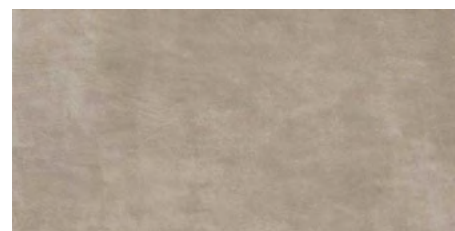

GROUND TORTORA
30X60



GROUND



GROUND LIGHT GREY
20X60

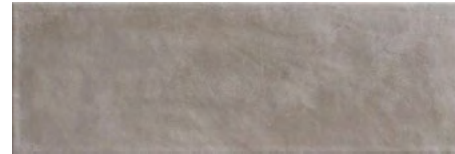

GROUND GREY
20X60



60X60
59,2X59,2



30X60
45X45



GROUND LIGHT GREY
60X60
59,2X59,2 RET.
45X45



GROUND GREY
60X60
59,2X59,2 RET.
45X45

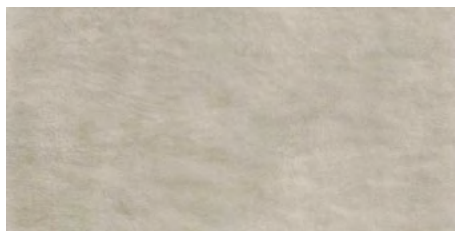

GROUND LIGHT GREY
30X60

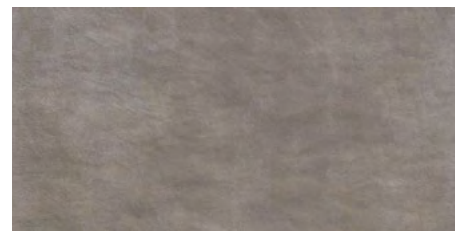

GROUND GREY
30X60

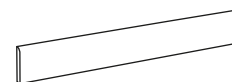

RODAPÉ GROUND
8X60
8X59,2
8X45



ZERO WHITE
20X60



ZERO CREAM
20X60



ZERO TORTORA
20X60

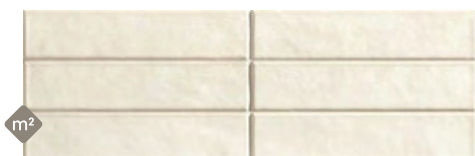

FORCE WHITE
20X60



FORCE CREAM
20X60

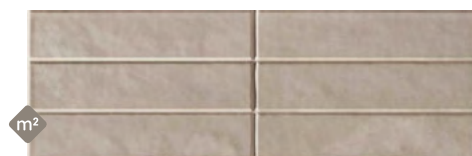

FORCE TORTORA
20X60



SOIL WHITE
20X60

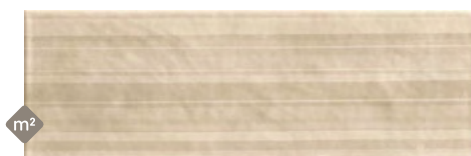

SOIL CREAM
20X60



SOIL TORTORA
20X60



BACKGROUND WHITE
20X60



BACKGROUND CREAM
20X60



BACKGROUND TORTORA
20X60

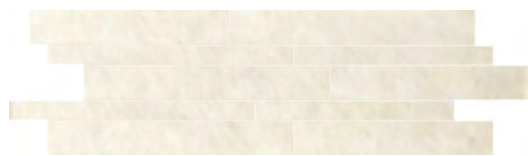

RIBBON WHITE
19X59

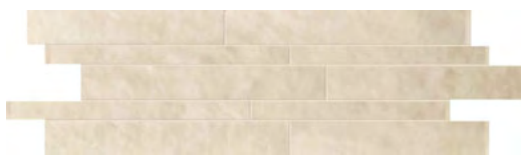

RIBBON CREAM
19X59



RIBBON TORTORA
19X59



GROUND



ZERO LIGHT GREY
20X60



ZERO GREY
20X60



FORCE LIGHT GREY
20X60



FORCE GREY
20X60



SOIL LIGHT GREY
20X60



SOIL GREY
20X60



BACKGROUND LIGHT GREY
20X60



BACKGROUND GREY
20X60



RIBBON LIGHT GREY
19X59

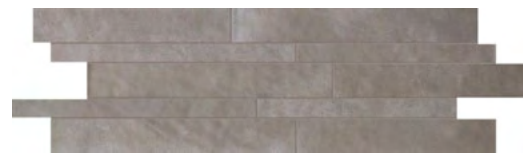

RIBBON GREY
19X59

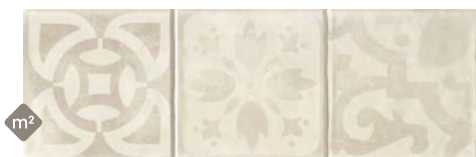

HOMELAND WHITE
20X60



HOMELAND CREAM
20X60



HOMELAND TORTORA
20X60



OFFSHORE WHITE
60X60
59,2X59,2 RET.

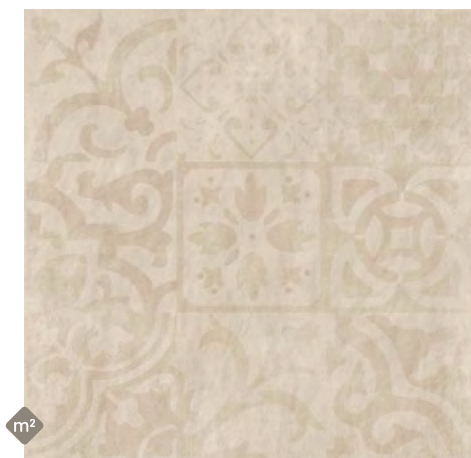

OFFSHORE CREAM
60X60
59,2X59,2 RET.

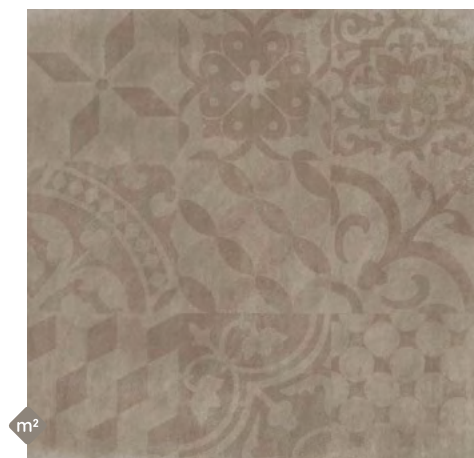

OFFSHORE TORTORA
60X60
59,2X59,2 RET.



HOMELAND *

Exemplo de composição com 12 peças
Example of 12 pieces composition
Exemple de composition avec 12 pièces
Beispiel einer Komposition mit 12 Stücken

*
Os diferentes desenhos são embalados aleatoriamente.
The available patterns are packed randomly.
Les différents motifs sont emballés aléatoirement.
Die verschiedenen Grafiken sind aleatorisch eingepackt.



m²

HOMELAND LIGHT GREY
20X60

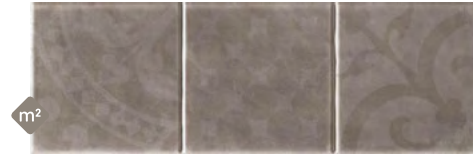

m²

HOMELAND GREY
20X60



m²

OFFSHORE LIGHT GREY
60X60
59,2X59,2 RET.



m²

OFFSHORE GREY
60X60
59,2X59,2 RET.



OFFSHORE *

Exemplo de composição com 10 peças
 Example of 10 pieces composition
 Exemple de composition avec 10 pièces
 Beispiel einer Komposition mit 10 Stücken

XXXX GROUND





GROUND



ZONE WHITE
20X60



ZONE CREAM
20X60

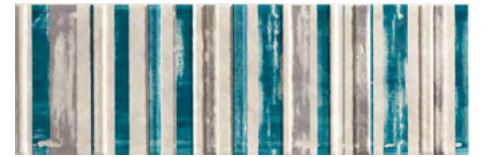

ZONE LIGHT GREY
20X60



BARRA ZONE WHITE
5X60



BARRA ZONE CREAM
5X60



BARRA ZONE LIGHT GREY
5X60



GLOBE WHITE
20X60

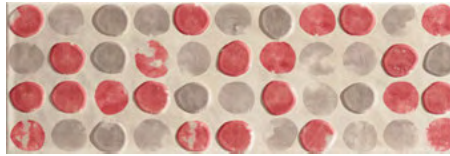

GLOBE CREAM
20X60

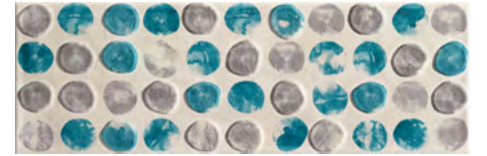

GLOBE LIGHT GREY
20X60



ROOTS WHITE
20X60

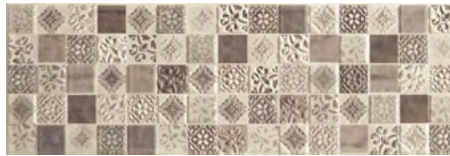

ROOTS CREAM
20X60



ROOTS LIGHT GREY
20X60

BARRA INOX ESCOVADA
1X300



MOSAIC GROUND WHITE
20X20



MOSAIC GROUND CREAM
20X20



MOSAIC GROUND TORTORA
20X20



MOSAIC GROUND LIGHT GREY
20X20

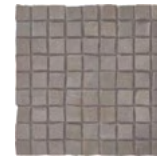

MOSAIC GROUND GREY
20X20



MOSAIC PLUS WHITE
20X20



MOSAIC PLUS CREAM
20X20



MOSAIC PLUS TORTORA
20X20



MOSAIC PLUS LIGHT GREY
20X20



MOSAIC PLUS GREY
20X20



BARRA FOCUS WHITE
5X30



BARRA FOCUS LIGHT GREY
5X30

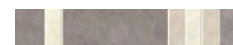

BARRA FOCUS GREY
5X30



VISION



REVESTIMENTO COM ACABAMENTO MATE OU SEMI-BRILHO
MATT OR SEMI-GLOSS WALL TILES
FAIÂNCES EN FINITION MAT OU SEMI-BRILLANT
WANDFLIESEN - MATT ODER HALBMATT OBERFLÄCHE
НАСТЕННАЯ КЕРАМИЧЕСКАЯ ПЛИТКА С МАТОВЫМ ИЛИ ПОЛУ-ГЛЯНЦЕВЫМ ПОКРЫТИЕМ



22x45

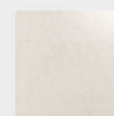

WHITE

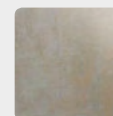

LIGHT GREY

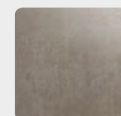

GREY

PAVIMENTO COM ACABAMENTO MATE OU SEMI-BRILHO
MATT OR GLOSSY FLOOR TILES
CARREUX SOL EN FINITION MAT OU SEMI-BRILLANT
BODENFLIESEN - MATT ODER HALBMATT OBERFLÄCHE
НАПОЛЬНАЯ ПЛИТКА С МАТОВЫМ ИЛИ ПОЛУ-ГЛЯНЦЕВЫМ ПОКРЫТИЕМ



45x45

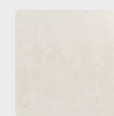

WHITE

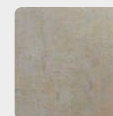

LIGHT GREY

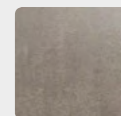

GREY

VISION





VISION WHITE 45X45

KEEP
CALM
and
MAKE
COFFEE



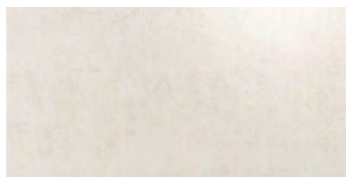

VISION WHITE
22,5X45

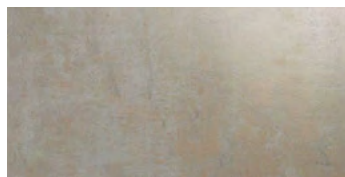

VISION LIGHT GREY
22,5X45

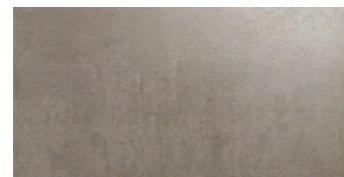

VISION GREY
22,5X45

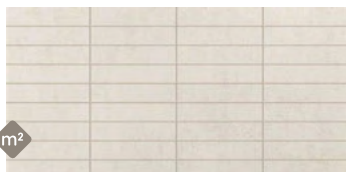

VISION PRÉ-CORTE WHITE
22,5X45

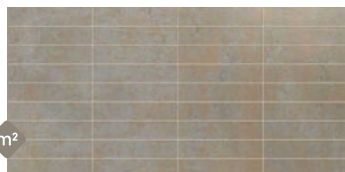

VISION PRÉ-CORTE LIGHT GREY
22,5X45



VISION PRÉ-CORTE GREY
22,5X45



BARRA BEADS WHITE
5X45
STOCK OFF



BARRA BEADS LIGHT GREY
5X45
STOCK OFF



BARRA BEADS GREY
5X45
STOCK OFF



BARRA BEADS WHITE
5X22,5
STOCK OFF



BARRA BEADS LIGHT GREY
5X22,5
STOCK OFF



BARRA BEADS GREY
5X22,5
STOCK OFF



BARRA TWEED WHITE
5X45



BARRA TWEED LIGHT GREY
5X45



BARRA TWEED GREY
5X45



BARRA TWEED WHITE
5X22,5



BARRA TWEED LIGHT GREY
5X22,5



BARRA TWEED GREY
5X22,5

BARRA INOX BRILHO
1X100

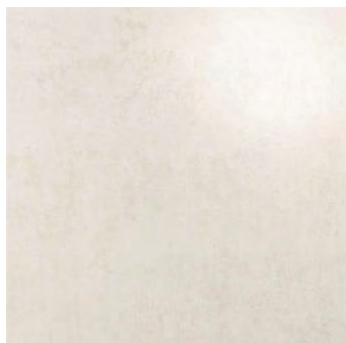

VISION WHITE
45X45

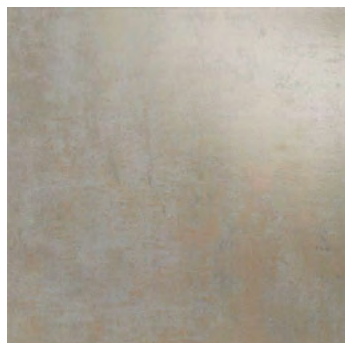

VISION LIGHT GREY
45X45

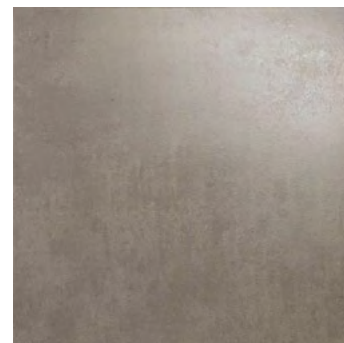

VISION GREY
45X45



RODAPÉ VISION
8X45



ESSENCE



REVESTIMENTO COM ACABAMENTO MATE OU SEMI-BRILHO
MATT OR SEMI-GLOSS WALL TILES
FAÏANCES EN FINITION MAT OU SEMI-BRILLANT
WANDFLIESEN - MATT ODER HALBMATT OBERFLÄCHE
НАСТЕННАЯ КЕРАМИЧЕСКАЯ ПЛИТКА С МАТОВЫМ ИЛИ ПОЛУ-ГЛЯНЦЕВЫМ ПОКРЫТИЕМ



22x33

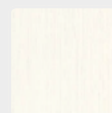

WHITE



TORTORA

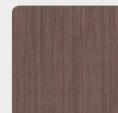

BROWN

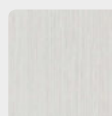

LIGHT GREY

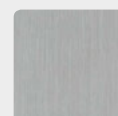

GREY



ANTRACITE

PAVIMENTO COM ACABAMENTO MATE OU SEMI-BRILHO
MATT OR GLOSSY FLOOR TILES
CARREAUX SOL EN FINITION MAT OU SEMI-BRILLANT
BODENFLIESEN - MATT ODER HALBMATT OBERFLÄCHE
НАПОЛЬНАЯ ПЛИТКА С МАТОВЫМ ИЛИ ПОЛУ-ГЛЯНЦЕВЫМ ПОКРЫТИЕМ



33x33



WHITE

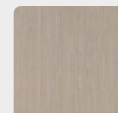

TORTORA

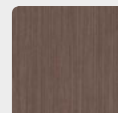

BROWN

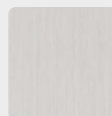

LIGHT GREY

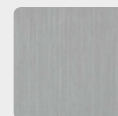

GREY

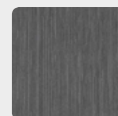

ANTRACITE

ESSENCE





ESSENCE WHITE
22,5X33,3



ESSENCE TORTORA
22,5X33,3



ESSENCE BROWN
22,5X33,3



ESSENCE LIGHT GREY
22,5X33,3

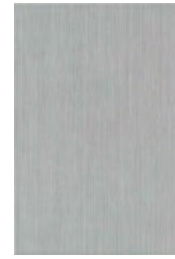

ESSENCE GREY
22,5X33,3



ESSENCE ANTRACITE
22,5X33,3



ESSENCE
PRÉ-CORTE WHITE
22,5X33,3

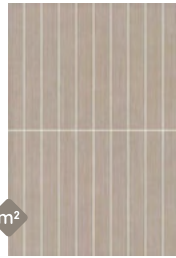

ESSENCE
PRÉ-CORTE TORTORA
22,5X33,3

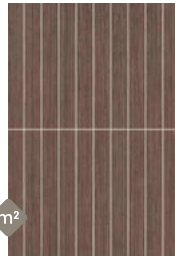

ESSENCE
PRÉ-CORTE BROWN
22,5X33,3



ESSENCE
PRÉ-CORTE LIGHT GREY
22,5X33,3

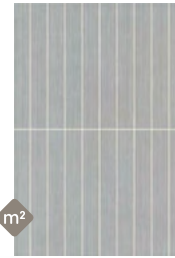

ESSENCE
PRÉ-CORTE GREY
22,5X33,3

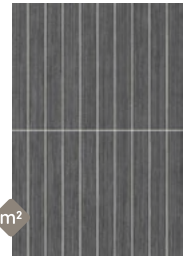

ESSENCE
PRÉ-CORTE ANTRACITE
22,5X33,3



ESSENCE STORIES WHITE
22,5X33,3



ESSENCE DRIP
WHITE
22,5X33,3



BARRA DRIP
WHITE
5,5X33,3



ESSENCE STORIES LIGHT GREY
22,5X33,3



ESSENCE DRIP
LIGHT GREY
22,5X33,3



BARRA DRIP
LIGHT GREY
5,5X33,3



BARRA STORIES WHITE
5,1X33,3



BARRA STORIES LIGHT GREY
5,1X33,3



LISTELO STORIES WHITE
2,5X33,3



BARRA DRIP
WHITE
5,5X22,5



LISTELO STORIES LIGHT GREY
2,5X33,3



BARRA DRIP
LIGHT GREY
5,5X22,5



ESSENCE WHITE
33,3X33,3

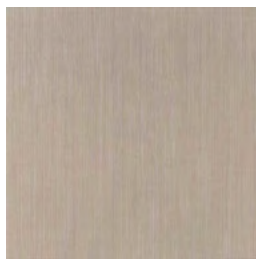

ESSENCE TORTORA
33,3X33,3



ESSENCE BROWN
33,3X33,3



ESSENCE LIGHT GREY
33,3X33,3



ESSENCE GREY
33,3X33,3



ESSENCE ANTRACITE
33,3X33,3





Coleção
Collection
Kollektion
Коллекция

PLACE



PAVIMENTO E REVESTIMENTO
FLOOR AND WALL TILES
FAÏENCES ET CARREAUX SOL
WANDFLIESEN UND BODENFLIESEN
ПЛИТКА ОБЛИЦОВОЧНАЯ И НАПОЛЬНАЯ



60x60



30x60



45x45

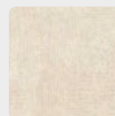

WHITE

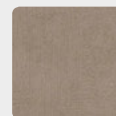

TORTORA

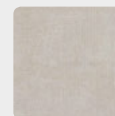

LIGHT GREY

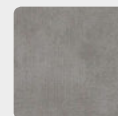

GREY



ANTRACITE

PLACE





PLACE GREY 59,2X59,2 RET. || PLACE LIGHT GREY 29,5X59,2 RET.

PLACE

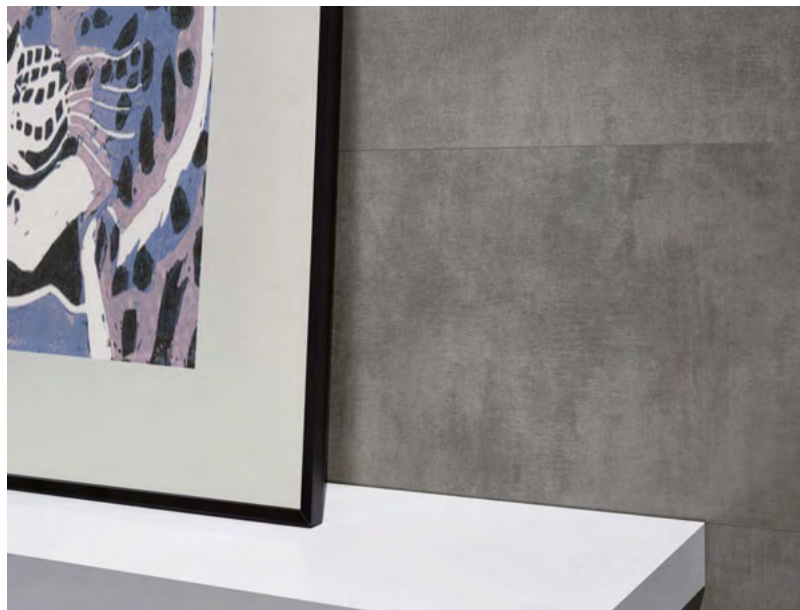



XXXX
XXXX
XXXX
XXXX

PLACE



60X60
59,2X59,2
29,5X59,2
29,5X46,5

31,4X61,2
45X45

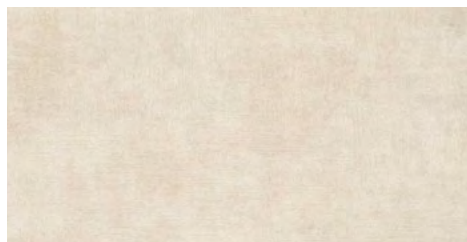

PLACE WHITE
31,4X61,2
29,5X59,2 RET.

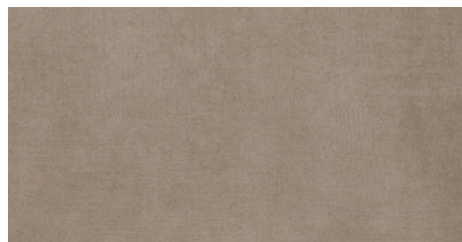

PLACE TORTORA
31,4X61,2
29,5X59,2 RET.



PLACE WHITE
60X60
59,2X59,2 RET.
45X45

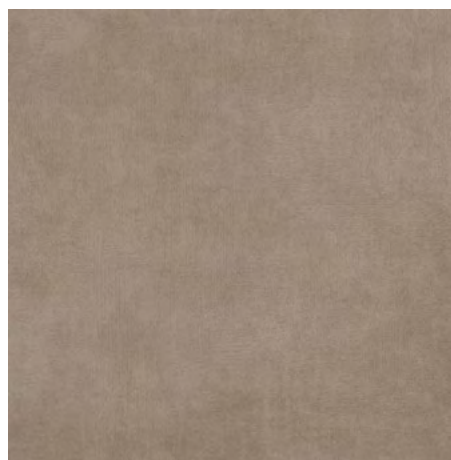

PLACE TORTORA
60X60
59,2X59,2 RET.
45X45

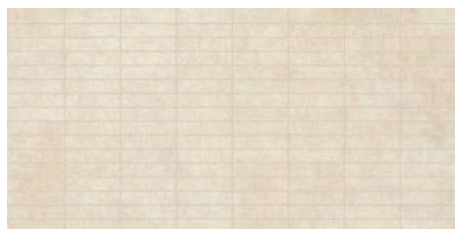

PLACE WHITE PRÉ-CORTE
29,5X59,2 RET.

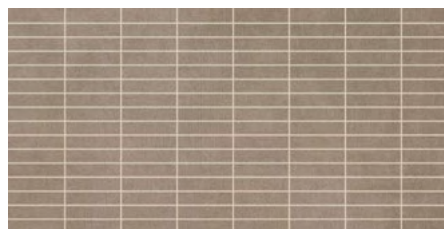

PLACE TORTORA PRÉ-CORTE
29,5X59,2 RET.



WHITE BRICKS
29,5X46,5



TORTORA BRICKS
29,5X46,5



TACO PLACE WHITE
5X5

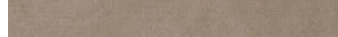

TIRA PLACE TORTORA
5X45

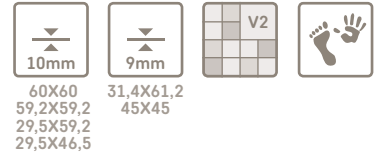

60X60
59,2X59,2
29,5X59,2
29,5X46,5

31,4X61,2
45X45



PLACE LIGHT GREY
31,4X61,2
29,5X59,2 RET.



PLACE GREY
31,4X61,2
29,5X59,2 RET.

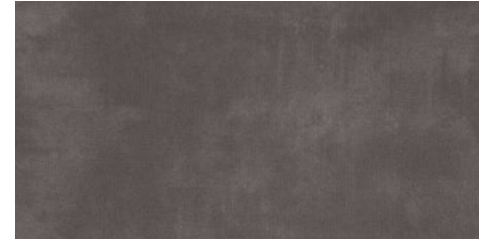

PLACE ANTRACITE
31,4X61,2
29,5X59,2 RET.



PLACE LIGHT GREY
60X60
59,2X59,2 RET.
45X45



PLACE GREY
60X60
59,2X59,2 RET.
45X45

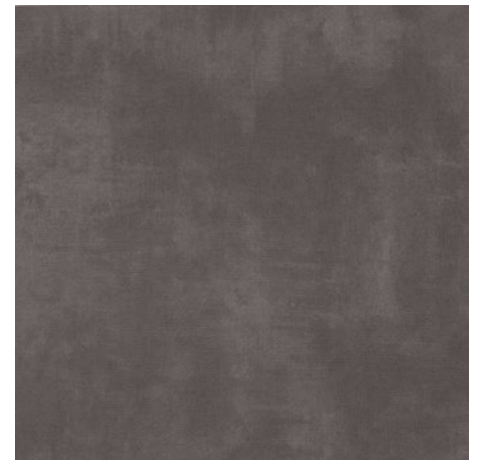

PLACE ANTRACITE
60X60
59,2X59,2 RET.
45X45

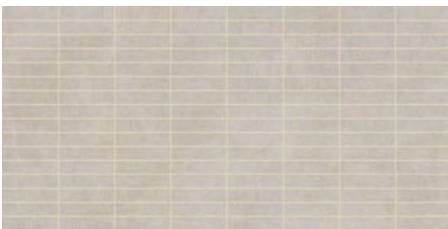

PLACE LIGHT GREY PRÉ-CORTE
29,5X59,2 RET.



PLACE GREY PRÉ-CORTE
29,5X59,2 RET.



PLACE ANTRACITE PRÉ-CORTE
29,5X59,2 RET.

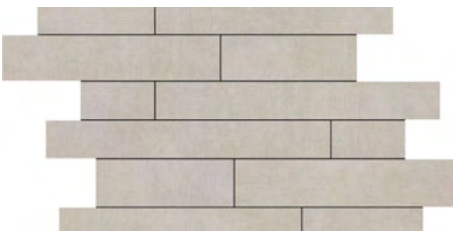

LIGHT GREY BRICKS
29,5X46,5

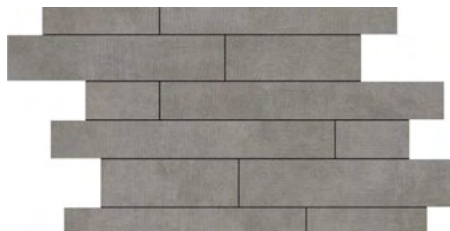

GREY BRICKS
29,5X46,5

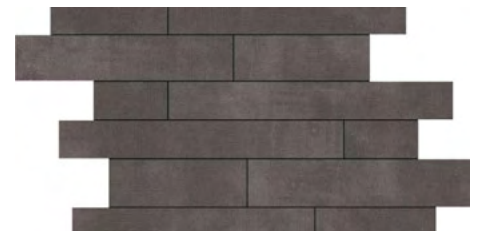

ANTRACITE BRICKS
29,5X46,5



TACO PLACE LIGHT GREY
5X5



TIRA PLACE GREY
5X45

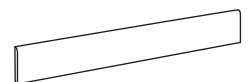

RODAPÉ PLACE
10X60
9,5X59,2 RET.
8X45





Coleção
Collection
Kollektion
Коллекция



WILDWOOD

PAVIMENTO E REVESTIMENTO
FLOOR AND WALL TILES
FAÏENCES ET CARREAUX SOL
WANDFLIESEN UND BODENFLIESEN
ПЛИТКА ОБЛИЦОВОЧНАЯ И НАПОЛЬНАЯ



15x75

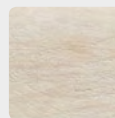

WHITE

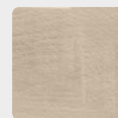

BEIGE

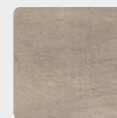

TORTORA

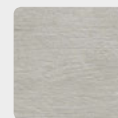

LIGHT GREY



GREY

ANTI-DERRAPANTE (DIN 51130)
NON-SLIPPERY (DIN 51130)
ANTIDÉRAPANT (DIN 51130)
RUTSCHSICHER (DIN 51130)
ПРОТИВОСКОЛЬЗЯЩИЙ (DIN 51130)



ANTI-DERRAPANTE (DIN 51097)
NON-SLIPPERY (DIN 51097)
ANTIDÉRAPANT (DIN 51097)
RUTSCHFEST (DIN 51097)
ПРОТИВОСКОЛЬЗЯЩИЙ (DIN 51097)



15x75

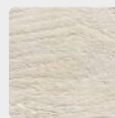

WHITE

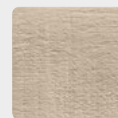

BEIGE

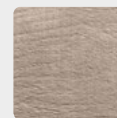

TORTORA



LIGHT GREY



GREY

WILDWOOD





WILDWOOD GREY 15X75

XXXX
XXXX
XXXX
XXXX
WILDWOOD





XXXXX
WILDWOOD



WILDWOOD





WILDWOOD GREY
15X75



GREY GLADE
15X75



WILDWOOD LIGHT GREY
15X75

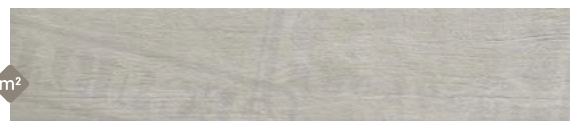

LIGHT GREY GLADE
15X75



WILDWOOD WHITE
15X75

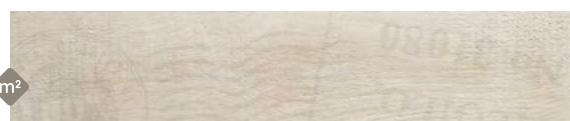

WHITE GLADE
15X75



WILDWOOD BEIGE
15X75



BEIGE GLADE
15X75



WILDWOOD TORTORA
15X75

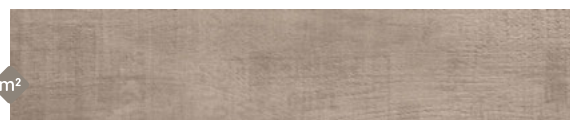

TORTORA GLADE
15X75

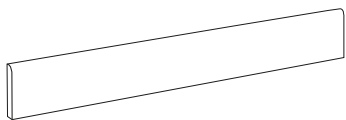

GLADE

Exemplo de composição com 7 peças
 Example of 7 pieces composition
 Exemple de composition avec 7 pièces
 Beispiel einer Komposition mit 7 Stücken

Os diferentes desenhos são embalados aleatoriamente.
 The available patterns are packed randomly.
 Les différents motifs sont emballés aléatoirement.
 Die verschiedenen Grafiken sind aleatorisch eingepackt.

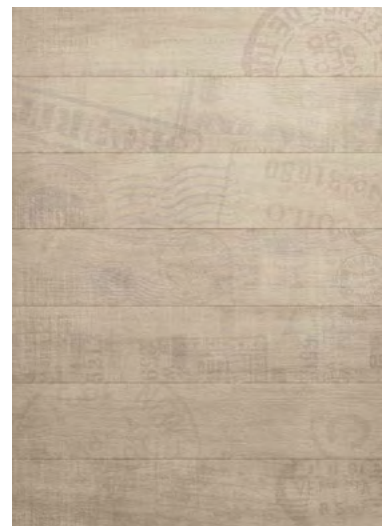



WILDWOOD



BRICKS GREY
15X63



WILDWOOD GREY ANTI-SLIP
15X75



BRICKS LIGHT GREY
15X63



WILDWOOD LIGHT GREY ANTI-SLIP
15X75



BRICKS WHITE
15X63



WILDWOOD WHITE ANTI-SLIP
15X75



BRICKS BEIGE
15X63



WILDWOOD BEIGE ANTI-SLIP
15X75



BRICKS TORTORA
15X63



WILDWOOD TORTORA ANTI-SLIP
15X75

Sugestões de aplicação
Laying suggestions
Suggestions de pose
Anwendungsvorschläge

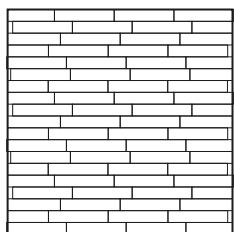

PÁG.48

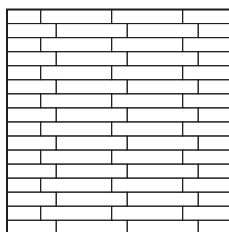

PÁG.50

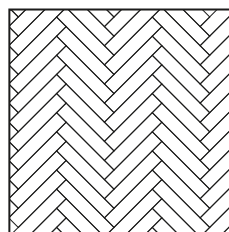

PÁG.51

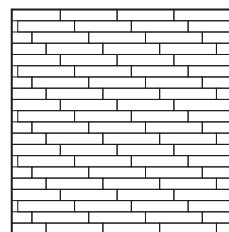

PÁG.52

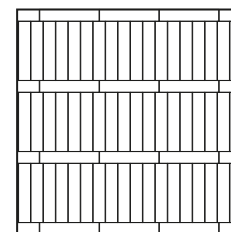

PÁG.54

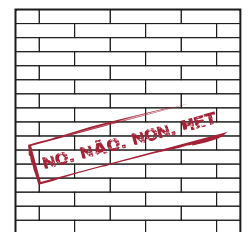





Coleção
Collection
Kollektion
Коллекция

FUSION



PAVIMENTO E REVESTIMENTO
FLOOR AND WALL TILES
FAÏENCES ET CARREAUX SOL
WANDFLIESEN UND BODENFLIESEN
ПЛИТКА ОБЛИЦОВОЧНАЯ И НАПОЛЬНАЯ



15x75

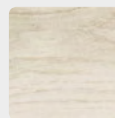

WHITE

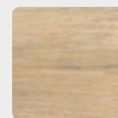

BEIGE

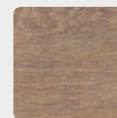

BROWN

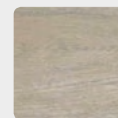

TORTORA



GREY

ANTI-DERRAPANTE (DIN 51130)
NON-SLIPPERY (DIN 51130)
ANTIDÉRAPANT (DIN 51130)
RUTSCHSICHER (DIN 51130)
ПРОТИВОСКОЛЬЗЯЩИЙ (DIN 51130)



ANTI-DERRAPANTE (DIN 51097)
NON-SLIPPERY (DIN 51097)
ANTIDÉRAPANT (DIN 51097)
RUTSCHFEST (DIN 51097)
ПРОТИВОСКОЛЬЗЯЩИЙ (DIN 51097)



15x75

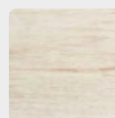

WHITE

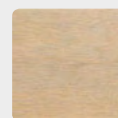

BEIGE

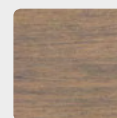

BROWN

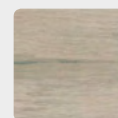

TORTORA

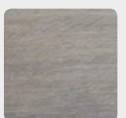

GREY

XXXX FUSION





FUSION BROWN 15X75

XXXX FUSION





FUSION



FUSION GREY
15X75

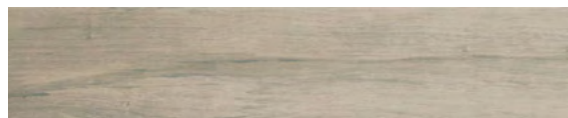

FUSION TORTORA
15X75



FUSION WHITE
15X75



FUSION BEIGE
15X75



FUSION BROWN
15X75

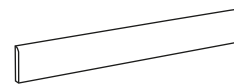

RODAPÉ FUSION
8X50

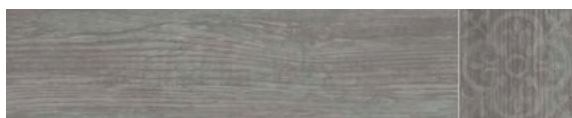

LOTUS GREY PRÉ-CORTE
15X75



LOTUS TORTORA PRÉ-CORTE
15X75



LOTUS WHITE PRÉ-CORTE
15X75



LOTUS BEIGE PRÉ-CORTE
15X75



LOTUS BROWN PRÉ-CORTE
15X75

LOTUS

Exemplo de composição com 3 peças
Example of 3 pieces composition
Exemple de composition avec 3 pièces
Beispiel einer Komposition mit 3 Stücken

Os diferentes desenhos são embalados aleatoriamente.
The available patterns are packed randomly.
Les différents motifs sont emballés aléatoirement.
Die verschiedenen Grafiken sind aleatorisch eingepackt.





INTERFUSION GREY
15X37

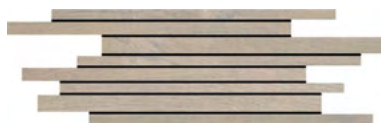

INTERFUSION TORTORA
15X37

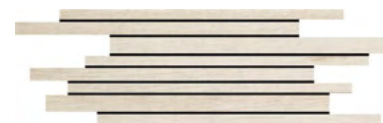

INTERFUSION WHITE
15X37



INTERFUSION BEIGE
15X37



INTERFUSION BROWN
15X37

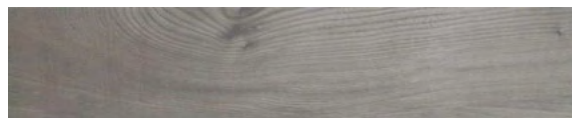

FUSION GREY ANTI-SLIP
15X75



FUSION TORTORA ANTI-SLIP
15X75



FUSION WHITE ANTI-SLIP
15X75



FUSION BEIGE ANTI-SLIP
15X75



FUSION BROWN ANTI-SLIP
15X75



Coleção
Collection
Kollektion
Коллекция

SOUL



PAVIMENTO E REVESTIMENTO
FLOOR AND WALL TILES
FAÏENCES ET CARREAUX SOL
WANDFLIESEN UND BODENFLIESEN
ПЛИТКА ОБЛИЦОВОЧНАЯ И НАПОЛЬНАЯ



30x60



PAVIMENTO COM ACABAMENTO MATE OU SEMI-BRILHO
MATT OR GLOSSY FLOOR TILES
CARREAUX SOL EN FINITION MAT OU SEMI-BRILLANT
BODENFLIESEN - MATT ODER HALBMATT OBERFLÄCHE
НАПОЛЬНАЯ ПЛИТКА С МАТОВЫМ ИЛИ ПОЛУ-ГЛЯНЦЕВЫМ ПОКРЫТИЕМ



50x50



33x33

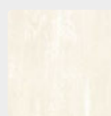

FEEL WHITE

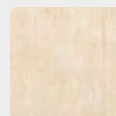

SPIRIT PEARL

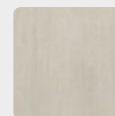

FLOW GREY

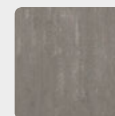

PASSION
ANTRACITE

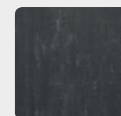

BODY BLACK

XXXX
XXXX
XXXX
XXXX

SOUL







SOUL



SOUL FEEL WHITE
31,4X61,2
30X60 RET.

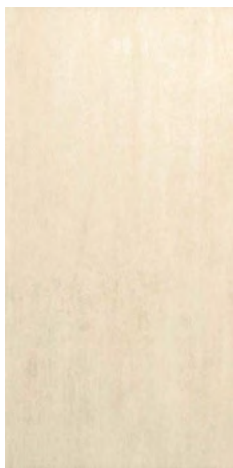

SOUL SPIRIT PEARL
31,4X61,2
30X60 RET.

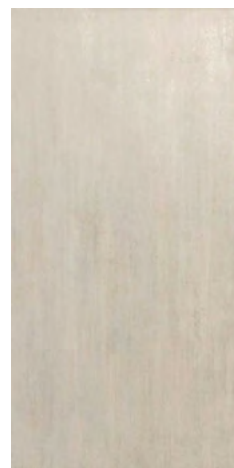

SOUL FLOW GREY
31,4X61,2
30X60 RET.

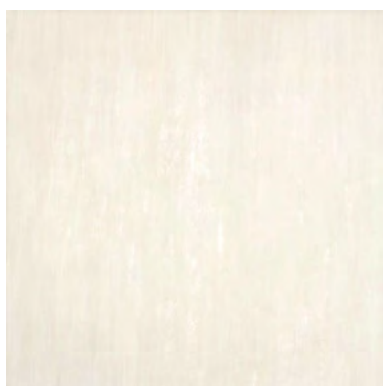

SOUL FEEL WHITE
50X50
48,6X48,6 RET.
33,3X33,3

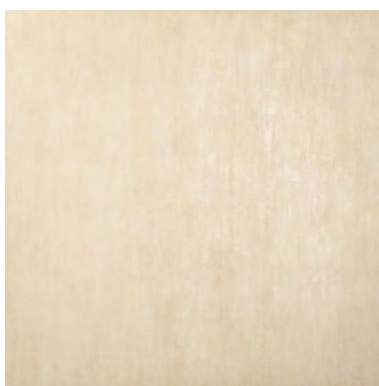

SOUL SPIRIT PEARL
50X50
48,6X48,6 RET.
33,3X33,3

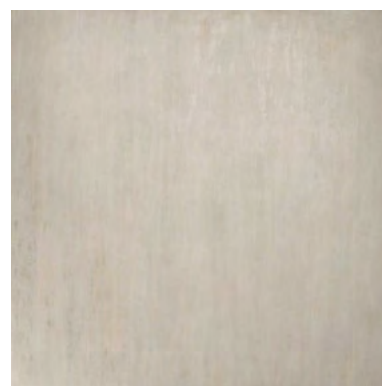

SOUL FLOW GREY
50X50
48,6X48,6 RET.
33,3X33,3

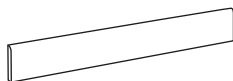

RODAPÉ SOUL
8X50
8X33,3

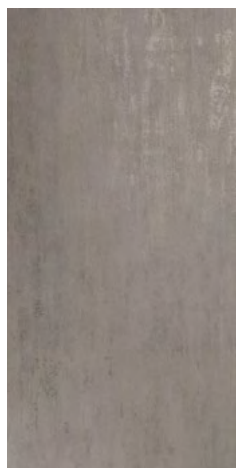

SOUL PASSION ANTRACITE
31,4X61,2
30X60 RET.

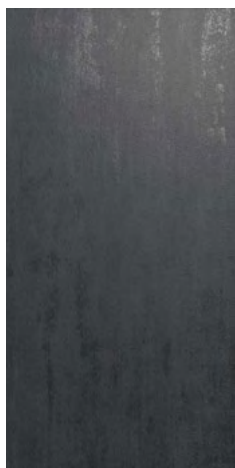

SOUL BODY BLACK
31,4X61,2
30X60 RET.

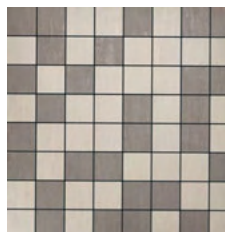

MOSAICO SOUL
GREY/ANTRACITE
30X30 (3,5X3,5)

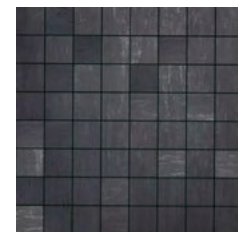

MOSAICO SOUL BLACK
30X30 (3,5X3,5)

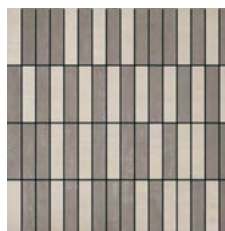

TIRAS SOUL
GREY/ANTRACITE
30X30 (1,6X7,3)

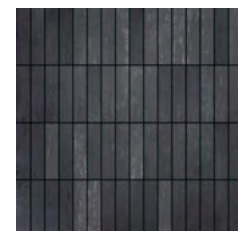

TIRAS SOUL BLACK
30X30 (1,6X7,3)



BARRA STEEL CROSS
4,5X48,6
STOCK OFF

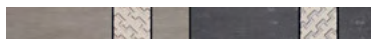

BARRA INTERLUDE
4,8X48,6



BARRA STEEL LINE
4,5X48,6
STOCK OFF

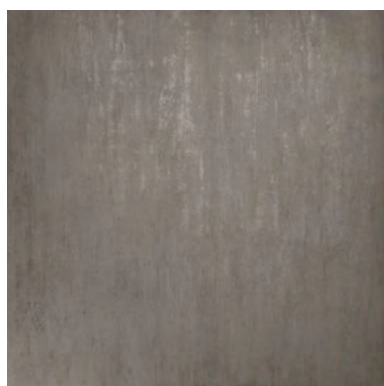

SOUL PASSION ANTRACITE
50X50
48,6X48,6 RET.
33,3X33,3

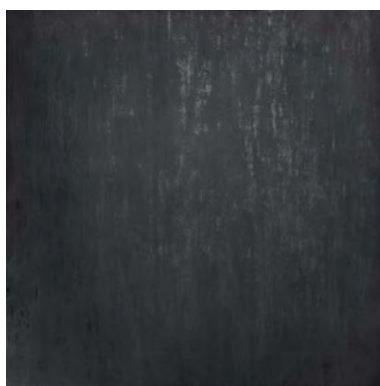

SOUL BODY BLACK
50X50
48,6X48,6 RET.
33,3X33,3



CHESS BOARD GREY
48,6X48,6 RET.
STOCK OFF

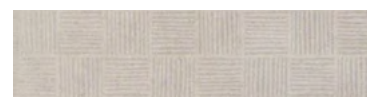

BARRA CHESS BOARD GREY
12X48,6
STOCK OFF



CANTO CHESS BOARD
12X12
STOCK OFF



FEVER



PAVIMENTO COM ACABAMENTO MATE OU SEMI-BRILHO
MATT OR GLOSSY FLOOR TILES
CARREAU SOL EN FINITION MAT OU SEMI-BRILLANT
BODENFLIESEN - MATT ODER HALBMATT OBERFLÄCHE
НАПОЛЬНАЯ ПЛИТКА С МАТОВЫМ ИЛИ ПОЛУ-ГЛЯНЦЕВЫМ ПОКРЫТИЕМ



45x45

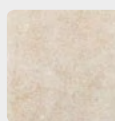

INTENSE
WHITE

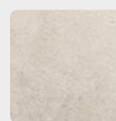

BURN GREY

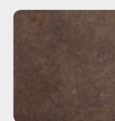

SPICY
BROWN

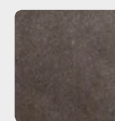

HOT BLACK

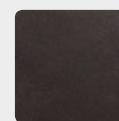

DEEP DARK

ANTI-DERRAPANTE (DIN 51130)
NON-SLIPPERY (DIN 51130)
ANTIDÉRAPANT (DIN 51130)
RUTSCHSICHER (DIN 51130)
ПРОТИВОСКОЛЬЗЯЩИЙ (DIN 51130)



ANTI-DERRAPANTE (DIN 51097)
NON-SLIPPERY (DIN 51097)
ANTIDÉRAPANT (DIN 51097)
RUTSCHFEST (DIN 51097)
ПРОТИВОСКОЛЬЗЯЩИЙ (DIN 51097)



45X45

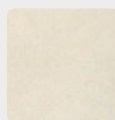

INTENSE
WHITE

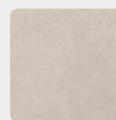

BURN GREY

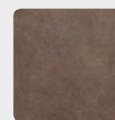

SPICY
BROWN

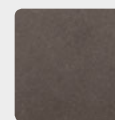

HOT BLACK

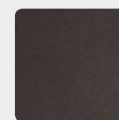

DEEP DARK





FEVER INTENSE WHITE ANTI-SLIP 45X45

FEVER



FEVER INTENSE WHITE
45X45

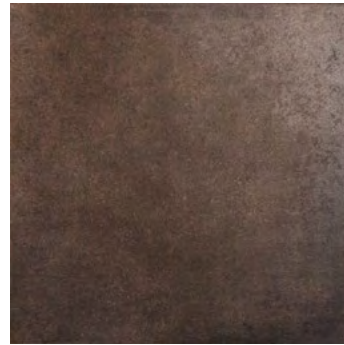

FEVER SPICY BROWN
45X45



FEVER INTENSE WHITE ANTI-SLIP
45X45

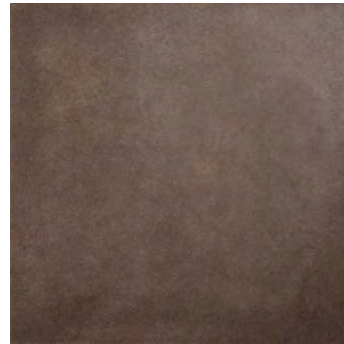

FEVER SPICY BROWN ANTI-SLIP
45X45



BARRA FLAME WHITE
6X35
STOCK OFF



FEVER MURETO BLACK/DARK
12.5X45
STOCK OFF



FEVER BURN GREY
45X45



FEVER HOT BLACK
45X45

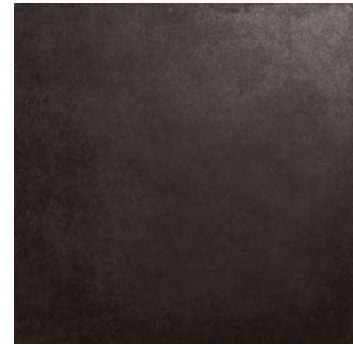

FEVER DEEP DARK
45X45

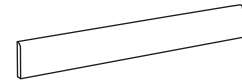

RODAPÉ FEVER
8X45



FEVER BURN GREY ANTI-SLIP
45X45

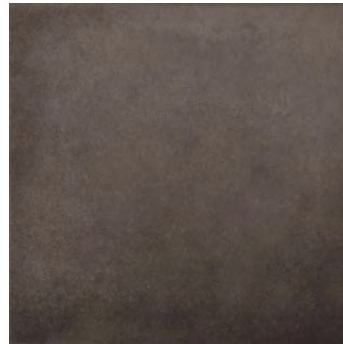

FEVER HOT BLACK ANTI-SLIP
45X45

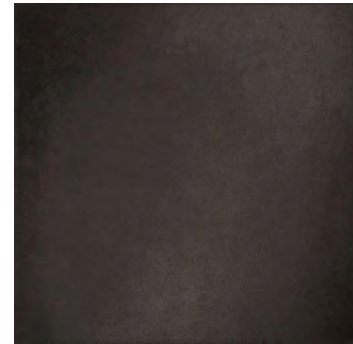

FEVER DEEP DARK ANTI-SLIP
45X45

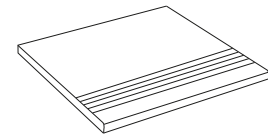

DEGRAU FEVER ANTI-SLIP
30X33,3



BARRA FLAME GREY
6X35
STOCK OFF



FEVER MURETO GREY/BLACK
12,5X45
STOCK OFF





Coleção
Collection
Kollektion
Коллекция

CANYON



ANTI-DERRAPANTE (DIN 51130)
NON-SLIPPERY (DIN 51130)
ANTIDÉRAPANT (DIN 51130)
RUTSCHSICHER (DIN 51130)
ПРОТИВОСКОЛЬЗЯЩИЙ (DIN 51130)



50x50



33x50



33x33

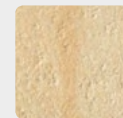

IVORY

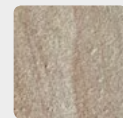

SAND



GREY

ANTI-DERRAPANTE (DIN 51130)
NON-SLIPPERY (DIN 51130)
ANTIDÉRAPANT (DIN 51130)
RUTSCHSICHER (DIN 51130)
ПРОТИВОСКОЛЬЗЯЩИЙ (DIN 51130)



ANTI-DERRAPANTE (DIN 51097)
NON-SLIPPERY (DIN 51097)
ANTIDÉRAPANT (DIN 51097)
RUTSCHFEST (DIN 51097)
ПРОТИВОСКОЛЬЗЯЩИЙ (DIN 51097)



60x60



50x50



33x50



33x33

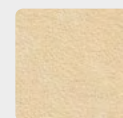

IVORY

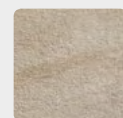

SAND



GREY

XXXX
XXXX
XXXX
XXXX
CANYON





×××
×××
×××
CANYON





CANYON

20mm 60,4X60,4
 9mm 50X50 33,3X50 33,3X33,3
 V4
 C ANTI-SLIP
 R12 ANTI-SLIP
 R10 NATURAL



CANYON 20MM IVORY ANTI-SLIP
60,4X60,4



CANYON 20MM SAND ANTI-SLIP
60,4X60,4



CANYON 20MM GREY ANTI-SLIP
60,4X60,4



CANYON IVORY ANTI-SLIP
50X50
33,3X33,3



CANYON SAND ANTI-SLIP
50X50
33,3X33,3



CANYON GREY ANTI-SLIP
50X50
33,3X33,3

CANYON IVORY NATURAL
50X50
33,3X33,3

CANYON SAND NATURAL
50X50
33,3X33,3

CANYON GREY NATURAL
50X50
33,3X33,3

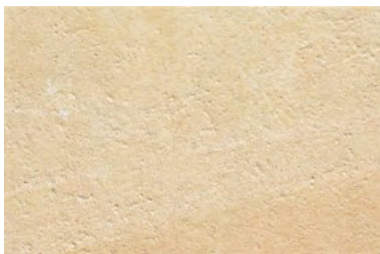

CANYON IVORY ANTI-SLIP
33,3X50

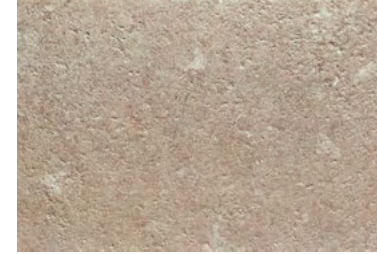

CANYON SAND ANTI-SLIP
33,3X50

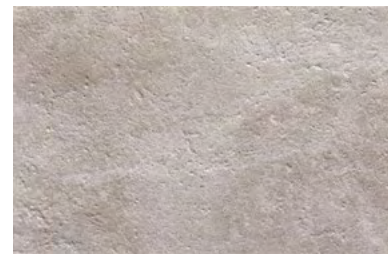

CANYON GREY ANTI-SLIP
33,3X50

CANYON IVORY NATURAL
33,3X50

CANYON SAND NATURAL
33,3X50

CANYON GREY NATURAL
33,3X50

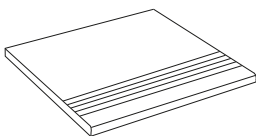

DEGRAU CANYON ANTI-SLIP
30X33,3

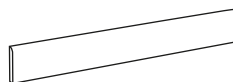

RODAPÉ CANYON
8X50
8X33,3

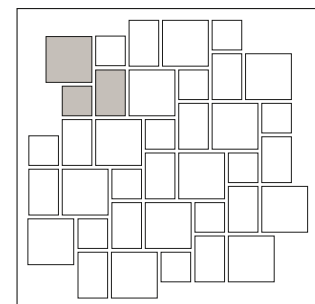

MULTIFORMATO R10
MULTIFORMATO R12

33,3X33,3	33,3X50	50X50
19,58%	32,55%	47,87%



TOSCANO



PAVIMENTO E REVESTIMENTO
FLOOR AND WALL TILES
FAÏENCES ET CARREAUX SOL
WANDFLIESEN UND BODENFLIESEN
ПЛИТКА ОБЛИЦОВОЧНАЯ И НАПОЛЬНАЯ



33x50



33x33



16x33



16x16

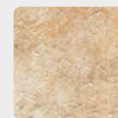

BEIGE

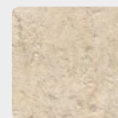

PÉROLA

XXXX
XXXX
XXXX
XXXX
TOSCANO



TOSCANO



TOSCANO BEIGE
33,3X50

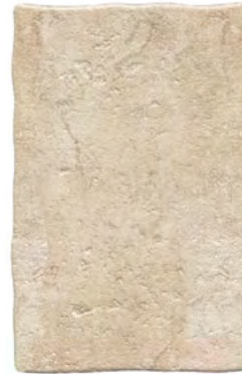

TOSCANO PÉROLA
33,3X50



TOSCANO BEIGE
33,3X33,3
16,5X16,5



TOSCANO PÉROLA
33,3X33,3
16,5X16,5



TOSCANO BEIGE
16,5X33,3



TOSCANO PÉROLA
16,5X33,3



RODAPÉ TOSCANO
8X33,3

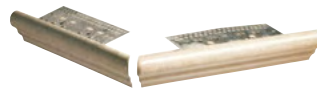

CANTO DEGRAU C/ SUPORTE METAL
TOSCANO BEIGE/PÉROLA
5,5X33,3X33,3



TOPO DEGRAU C/ SUPORTE METAL
TOSCANO BEIGE/PÉROLA
5,5X33,3

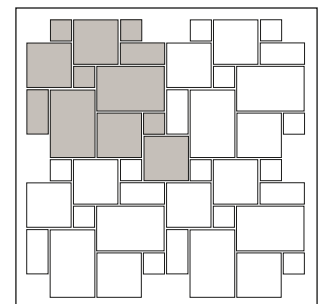

MULTIFORMATO

33,3X33,3	16,5X33,3	16,5X16,5	33,3X50
41,02%	13,52%	11,16%	34,30%



Coleção
Collection
Kollektion
Коллекция

PIRINÉUS



ANTI-DERRAPANTE (DIN 51130)
NON-SLIPPERY (DIN 51130)
ANTIDÉRAPANT (DIN 51130)
RUTSCHSICHER (DIN 51130)
ПРОТИВОСКОЛЬЗЯЩИЙ (DIN 51130)



ANTI-DERRAPANTE (DIN 51097)
NON-SLIPPERY (DIN 51097)
ANTIDÉRAPANT (DIN 51097)
RUTSCHFEST (DIN 51097)
ПРОТИВОСКОЛЬЗЯЩИЙ (DIN 51097)



33x50



33x33



16x33



16x16

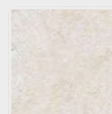

PÉROLA

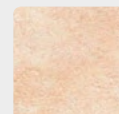

ROSADO

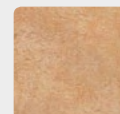

MEL

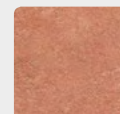

MARRON

XXXX PIRINÉUS



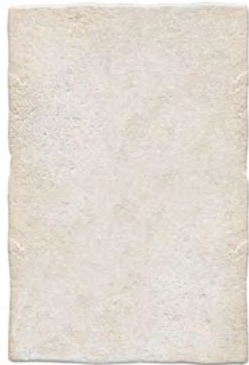

PIRINÉUS PÉROLA
33,3X50



PIRINÉUS ROSADO
33,3X50



PIRINÉUS MEL
33,3X50



PIRINÉUS MARRON
33,3X50



PIRINÉUS PÉROLA
16,5X33,3



PIRINÉUS ROSADO
16,5X33,3



PIRINÉUS MEL
16,5X33,3



PIRINÉUS MARRON
16,5X33,3



PIRINÉUS PÉROLA
33,3X33,3
16,5X16,5



PIRINÉUS ROSADO
33,3X33,3
16,5X16,5



PIRINÉUS MEL
33,3X33,3
16,5X16,5



PIRINÉUS MARRON
33,3X33,3
16,5X16,5

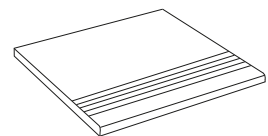

DEGRAU PIRINÉUS
30X33,3

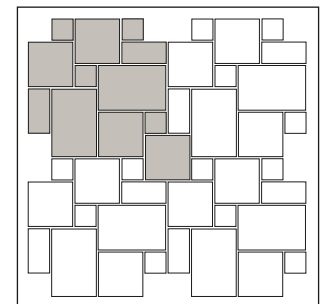

MULTIFORMATO

33,3X33,3	16,5X33,3	16,5X16,5	33,3X50
41,02%	13,52%	11,16%	34,30%



BUILDING

PAVIMENTO COM ACABAMENTO MATE OU SEMI-BRILHO
MATT OR GLOSSY FLOOR TILES
CARREUX SOL EN FINITION MAT OU SEMI-BRILLANT
BODENFLIESEN - MATT ODER HALBMATT OBERFLÄCHE
НАПОЛЬНАЯ ПЛИТКА С МАТОВЫМ ИЛИ ПОЛУ-ГЛЯНЦЕВЫМ ПОКРЫТИЕМ



ARGEL

45x45  9mm

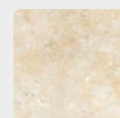

BEIGE

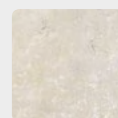

CINZA

TEJO

45x45  9mm

33x33  7,8mm

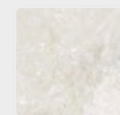

VERDE ÁGUA

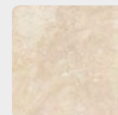

BEIGE

TURIM

45x45  9mm

33x33  7,8mm

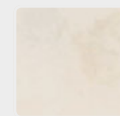

BEIGE

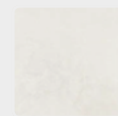

CINZA







TURIM BEIGE 45X45 || RODAPÉ TURIM BEIGE 8X45

BUILDING - ARGEL



ARGEL BEIGE
45X45



TACO CREME
4,6X4,6
STOCK OFF



TACO NEGRO
4,6X4,6



ARGEL CINZA
45X45



TACO VERDE
4,6X4,6



TACO VERMELHO ALICANTE
4,6X4,6

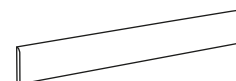

RODAPÉ ARGEL
8X45



TACO CASTANHO
4,6X4,6

BUILDING - TURIM

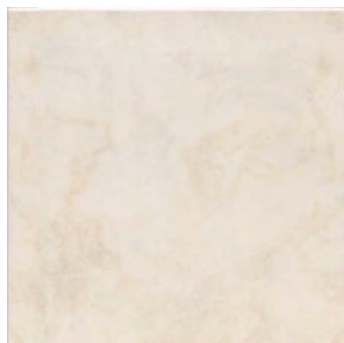
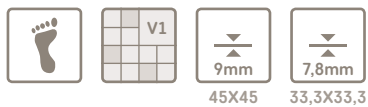

TURIM BEIGE
45X45
33,3X33,3

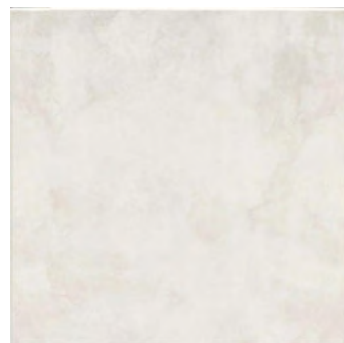

TURIM CINZA
45X45
33,3X33,3

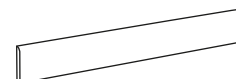

RODAPÉ TURIM
8x45
8x33,3

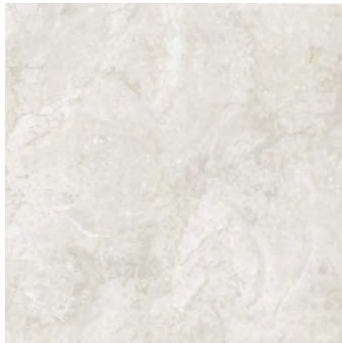

TEJO VERDE ÁGUA
45X45
33,3X33,3



BARRA TÂMEGA VERDE ÁGUA
22,5X45



CANTO TÂMEGA VERDE ÁGUA
22,5X22,5



BARRA TEJO VERDE ÁGUA
22,5X45



CANTO TEJO VERDE ÁGUA
22,5X22,5

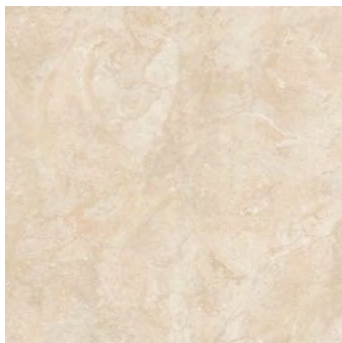

TEJO BEIGE
45X45
33,3X33,3



BARRA TÂMEGA BEIGE
22,5X45



CANTO TÂMEGA BEIGE
22,5X22,5



BARRA TEJO BEIGE
22,5X45



CANTO TEJO BEIGE
22,5X22,5

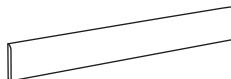

RODAPÉ TEJO
8x45
8x33,3

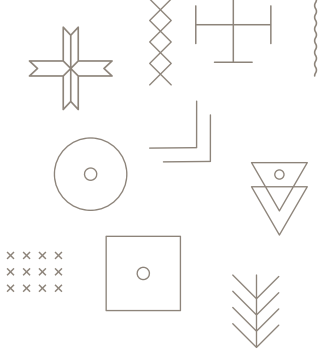

NON-SLIPPERY ANTIDÉRAPANT RUTSCHSICHER ПРОТИВОСКОЛЬЗЯЩИЙ ANTIDERRAPANTE



ANTI-DERRAPANTE

Em zonas de risco de escorregamento, a aplicação de material antiderrapante reduz consideravelmente o risco de escorregamento.

Alguns dos indicadores usados na medida do coeficiente de fricção são:

R – o ângulo de inclinação atingido durante o teste de resistência ao escorregamento.

(Classificação segundo a norma DIN 51130). Esta norma determina as propriedades antiderrapantes dos pavimentos utilizados em lugares onde se transita com pés calçados.

DIN 51097 - Norma que se utiliza para zonas húmidas com possibilidade de circular de pé descalço (zonas de piscina, balneários, etc)

NON-SLIPPERY

In areas at risk of slipping, the application of non-slip / anti-slip material greatly reduces the risk of slipping.

Some (of the) indicators used in the measurement of coefficient of friction are:

R - the angle of inclination achieved/reached during the slip resistance test.

(Classification according to DIN 51130). This standard determines the properties of non-slip/anti-slip flooring used in places where one walks with shod feet.

DIN 51097 - Standard that is used for wetland areas with the possibility of one walking barefoot (pool areas, changing rooms, etc.)

ANTIDÉRAPANT

Dans des zones présentant un risque de glissement, l'application de matériau antidérapant réduit considérablement ce risque.

Certains des indicateurs utilisés pour la mesure du coefficient de frottement sont:

R – l'angle d' inclinaison atteint pendant le test de résistance au glissement

(Classement selon la norme DIN 51130). Cette norme détermine les propriétés antidérapantes des revêtements de sols utilisés dans des lieux de circulation avec les pieds chaussés.

DIN 51097 - Norme qui est utilisée pour les zones humides où il est possible de circuler pieds nus (zones de piscine, vestiaires, etc.)

RUTSCHSICHERE FLIESEN

In Räumen und Bereichen mit Rutschgefahr ist der Einsatz von rutschsicheren Fliesen ratsam, da diese das Rutschrisiko beträchtlich hemmen.

Bei der Prüfung der rutschhemmenden Eigenschaft gelten die folgenden Begriffe:

R = Akzeptanzwinkel, d.h. Neigungswinkel der schiefen Ebene, bei dem die Prüfung bestanden wird.

(Klassifizierung laut Norm DIN 51130). Die Norm bestimmt die rutschhemmende Eigenschaft von Bodenbelägen in Bereichen, in denen man Schuhe trägt.

DIN 51097 - Norm für nassbelastete Barfußbereiche (Schwimmbad, Umkleieräume, etc)

ПРЕДОХРАНЕНИЕ ОТ СКОЛЬЖЕНИЯ

В местах с риском скольжения использование материала против скольжения значительно уменьшает риск скольжения.

При измерении коэффициента трения используют также следующие показатели:

R – максимальный угол наклона, достигнутый при тесте на сопротивление скольжению.

(Классификация согласно стандарту DIN 51130). Этот стандарт определяет свойства сопротивления скольжению покрытий, используемых на площадях, где происходит передвижение в обуви.

DIN 51097 - Стандарты, применяемые для влажных поверхностей, где возможно передвижение босиком (бассейны, санузлы, итд.)

DIN 51130					DIN 51097				
	≥ 6° - 10°	≥ 10° - 19°	≥ 19° - 27°	≥ 27° - 35°	≥ 35°		≥ 12°	≥ 18°	≥ 24°
	R9	R10	R11	R12	R13		A	B	C
<p>RESISTENTE AO ESCORREGAMENTO RESISTANT TO SLIPPAGE RÉSISTANT À LA GLISSANCE RUTSCHSICHERHEIT СОПРОТИВЛЕНИЕ СКОЛЬЖЕНИЮ</p>					<p>RESISTENTE AO ESCORREGAMENTO RESISTANT TO SLIPPAGE RÉSISTANT À LA GLISSANCE RUTSCHSICHERHEIT СОПРОТИВЛЕНИЕ СКОЛЬЖЕНИЮ</p>				

ANTIDERRAPANTE

NON-SLIPPERY || ANTIDÉRAPANT || RUTSCHSICHER || ПРОТИВОСКОЛЬЗЯЩИЙ



FUSION

PAG.
249



FUSION GREY ANTI-SLIP
15X75



FUSION TORTORA ANTI-SLIP
15X75



FUSION WHITE ANTI-SLIP
15X75



FUSION BEIGE ANTI-SLIP
15X75



FUSION BROWN ANTI-SLIP
15X75

fever

PAG.
275



FEVER INTENSE WHITE ANTI-SLIP
45X45

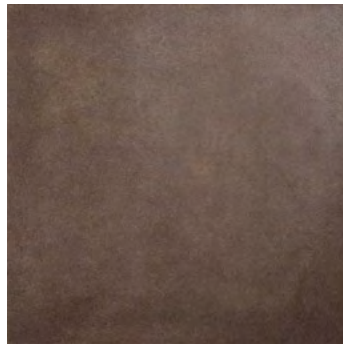

FEVER SPICY BROWN ANTI-SLIP
45X45



FEVER BURN GREY ANTI-SLIP
45X45

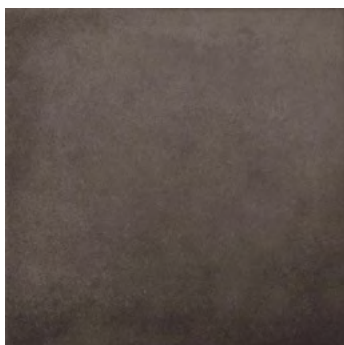

FEVER HOT BLACK ANTI-SLIP
45X45

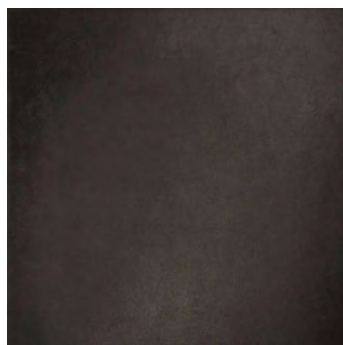

FEVER DEEP DARK ANTI-SLIP
45X45

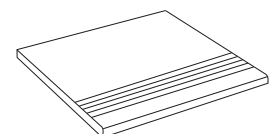

DEGRAU FEVER ANTI-SLIP
30X33,3

LOVE
CERAMIC TILES

ANTIDERRAPANTE

NON-SLIPPERY || ANTIDÉRAPANT || RUTSCHSICHER || ПРОТИВОСКОЛЬЗЯЩИЙ



R10

NATURAL



R12

ANTI-SLIP



C

ANTI-SLIP



V4



20mm

60,4X60,4



9mm

50X50
33,3X50
33,3X33,3

canyon

PAG.
312



CANYON 20MM IVORY ANTI-SLIP
60,4X60,4



CANYON 20MM SAND ANTI-SLIP
60,4X60,4



CANYON 20MM GREY ANTI-SLIP
60,4X60,4



CANYON IVORY ANTI-SLIP
50X50
33,3X33,3



CANYON SAND ANTI-SLIP
50X50
33,3X33,3

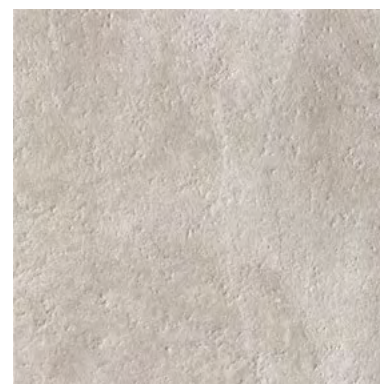

CANYON GREY ANTI-SLIP
50X50
33,3X33,3

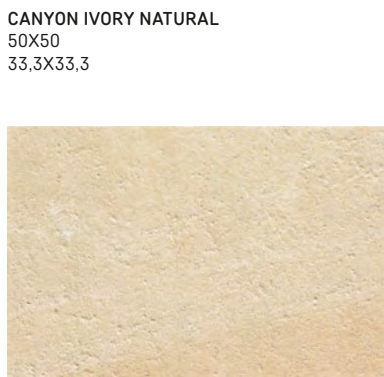

CANYON IVORY NATURAL
50X50
33,3X33,3



CANYON SAND NATURAL
50X50
33,3X33,3

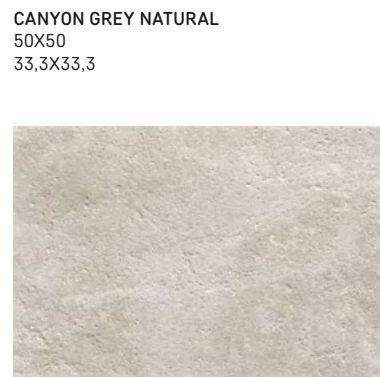

CANYON GREY NATURAL
50X50
33,3X33,3

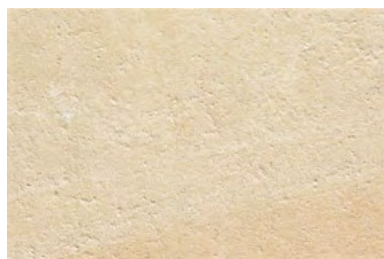

CANYON IVORY ANTI-SLIP
33,3X50

CANYON IVORY NATURAL
33,3X50

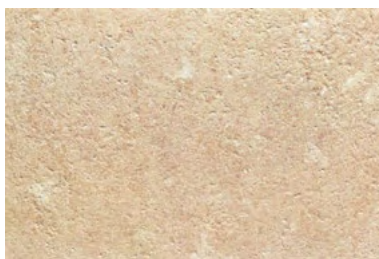

CANYON SAND ANTI-SLIP
33,3X50

CANYON SAND NATURAL
33,3X50

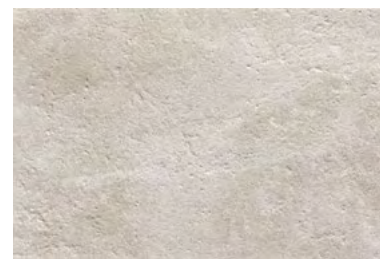

CANYON GREY ANTI-SLIP
33,3X50

CANYON GREY NATURAL
33,3X50

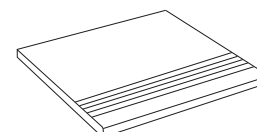

DEGRAU CANYON ANTI-SLIP
30X33,3

pirinéus

PAG.
297



PIRINÉUS PÉROLA
33,3X50



PIRINÉUS ROSADO
33,3X50



PIRINÉUS MEL
33,3X50



PIRINÉUS MARRON
33,3X50



PIRINÉUS PÉROLA
16,5X33,3



PIRINÉUS ROSADO
16,5X33,3



PIRINÉUS MEL
16,5X33,3



PIRINÉUS MARRON
16,5X33,3



PIRINÉUS PÉROLA
33,3X33,3
16,5X16,5



PIRINÉUS ROSADO
33,3X33,3
16,5X16,5



PIRINÉUS MEL
33,3X33,3
16,5X16,5



PIRINÉUS MARRON
33,3X33,3
16,5X16,5

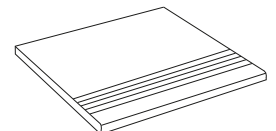

DEGRAU PIRINÉUS
30X33,3

WILDWOOD

PAG.
056

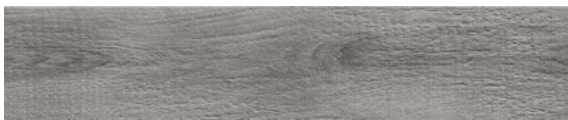

WILDWOOD GREY ANTI-SLIP
15X75



WILDWOOD LIGHT GREY ANTI-SLIP
15X75

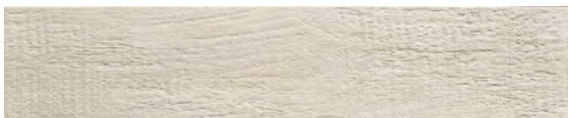

WILDWOOD WHITE ANTI-SLIP
15X75



WILDWOOD BEIGE ANTI-SLIP
15X75

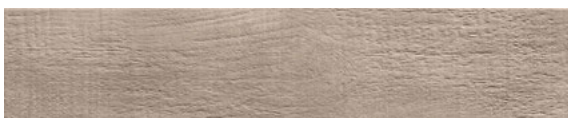

WILDWOOD TORTORA ANTI-SLIP
15X75

Technical Information
Information Technique
Technische Information
Техническая Информация

INFORMAÇÃO TÉCNICA

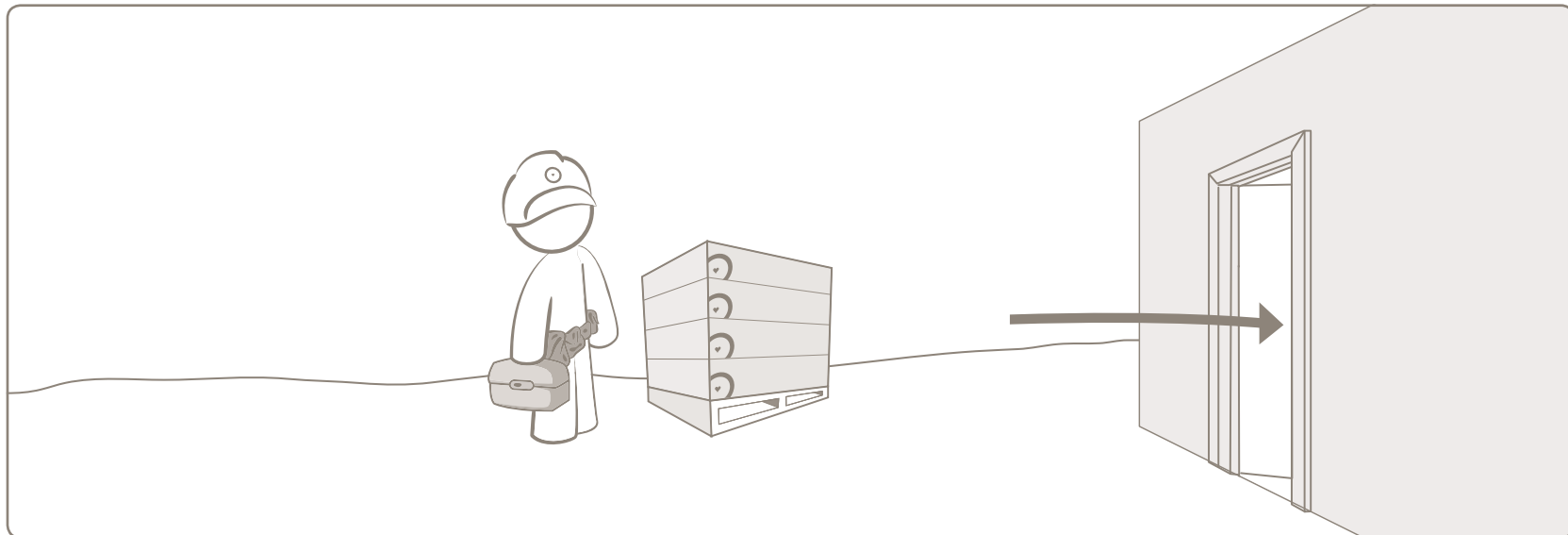

Antes de iniciar o assentamento do material cerâmico, deverá ter em consideração os seguintes aspetos:

- Verificar se o material cerâmico é indicado para utilizar no local selecionado de acordo com as suas especificações e características técnicas;
- Verificar se existe material suficiente para realizar a obra;
- Confirmar nas caixas se o produto é da mesma tonalidade, escolha e calibre.

O bom desempenho do material cerâmico depende fortemente das condições de aplicação pelo que é de extrema importância garantir os seguintes pressupostos:

Before (beginning the) laying (of) ceramic material, you should take the following aspects into account:

- Check if the ceramic material is suitable for (use at) the selected site, according to its specifications and technical characteristics;
- Check whether there is enough material to conclude the work;
- Check the boxes to see/confirm in the boxes if the product is in the same shade, choice and caliber.

The good performance of the ceramic material depends strongly on the conditions of application for which it is extremely important to ensure the following assumptions:

Avant de commencer la pose du matériau céramique, les aspects suivants devront être pris en considération:

- Vérifier si le matériau céramique est indiqué pour une utilisation dans le lieu choisi, conformément à ses spécifications et caractéristiques techniques;
- Vérifier s'il existe la quantité de matériau suffisante pour réaliser le chantier;
- Confirmer dans les boîtes si le produit est du même ton, de la même qualité, et du même calibre.

La bonne performance du matériau céramique dépend fortement des conditions d'application. Il est donc extrêmement important de garantir les conditions préalables suivantes:

Vor dem Beginn der Verlegearbeiten sollten Sie folgende Punkte berücksichtigen:

Bitte überprüfen Sie, ob die gewählte Fliese laut ihrer Oberflächenbeschaffenheit und ihren technischen Eigenschaften geeignet für das Einsatzgebiet ist;

Bitte prüfen Sie nach, ob die Menge der gewählten Fliese ausreicht, um das geplante Bauprojekt fertig zu stellen;

Bitte prüfen Sie, ob die Fliesen aus verschiedenen Kartons dieselbe Beschaffenheit, (Ton, Wahl und Kaliber) haben.

Die Leistungsfähigkeit der Fliese hängt stark davon ab, wie die Fliesen verlegt werden. Daher ist es sehr wichtig, die folgenden Punkte zu beachten:

Перед началом работ по утсановке керамического материала необходимо учесть следующие моменты:

- Проверить, подходит ли керамический материал для использования в назначенном месте согласно его свойствам и техническим характеристикам;
- Проверить, имеется ли материал в количестве, достаточном для производства работ;
- Проверить по упаковкам, является ли продукция того же оттенка, ассортимента и размера.

Хорошие эксплуатационные показатели использования керамического материала сильно зависят от условий кладки, поэтому исключительно важно обеспечить следующие предпосылки:

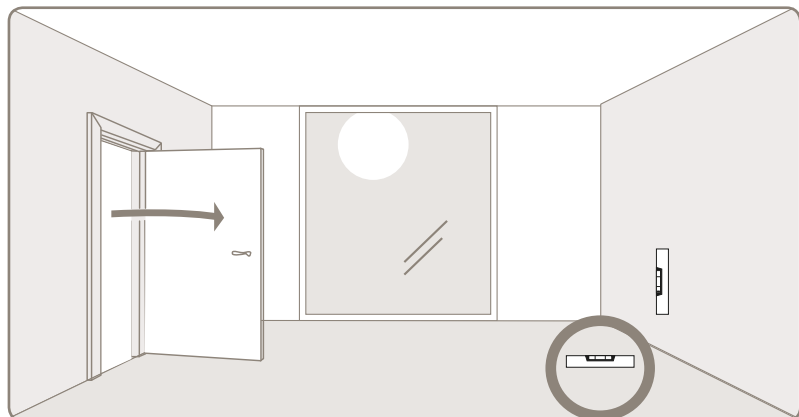

01



O SUPORTE

O suporte deve apresentar-se estável, limpo de resíduos, fendas e poeiras. Deverão ser respeitados os tempos de cura e estabilidade dos tratamentos a que possa ter sido sujeito. Deve fazer-se a verificação da planaridade do mesmo, procedendo à regularização, se necessário com a ajuda de produtos adequados a esse fim. Estes aspetos são vitais para pavimentos e revestimentos cerâmicos.

SUPPORT

The support must be stable, free of debris, dust and cracks. Curing times and stability of the treatments to which the support may have been subjected should be respected. You should check its flatness and stabilize it, if necessary with the help of products suitable for the purpose. These aspects are vital for wall and floor ceramic tiles.

LE SUPPORT

Le support doit être stable, exempt de résidus, fentes et poussières. Les temps de durcissement et de stabilité des traitements auxquels il doit être soumis devront être respectés. La planéité du support doit être vérifiée et le nivellement doit être réalisé si cela est nécessaire, à l'aide de produits appropriés. Ces aspects sont essentiels pour les revêtements de sol et muraux céramiques.

DER UNTERGRUND

Der Untergrund muss stabil, sauber, sowie frei von Rissen und Staub sein. Sollte der Untergrund vor dem Verlegen der Fliesen speziell behandelt werden müssen, so sollten Sie darauf achten, dass die Behandlung gut gelungen und abgeschlossen ist, bevor Sie die Fliesen verlegen. Sie sollten den Untergrund inspizieren. Falls er nicht eben ist, muss er mit Hilfe von passenden Produkten grundiert werden. Diese Vorsicht ist angebracht und eine unabdingbare Voraussetzung für das fachgerechte Verlegen von Boden- und Wandfliesen.

ОПОРНАЯ ОСНОВА

Опорная основа должна быть устойчивой, очищенной от отходов, трещин и пыли. Должны соблюдаться сроки полного высыхания и устойчивости процессов обработки, которым она может быть подвержена покрытия. Следует произвести проверку на плоскостность и, если нужно, отрегулировать ее с использованием предназначенных для этого материалы. Эти аспекты являются жизненно важными при установке керамических напольных покрытий и облицовке.

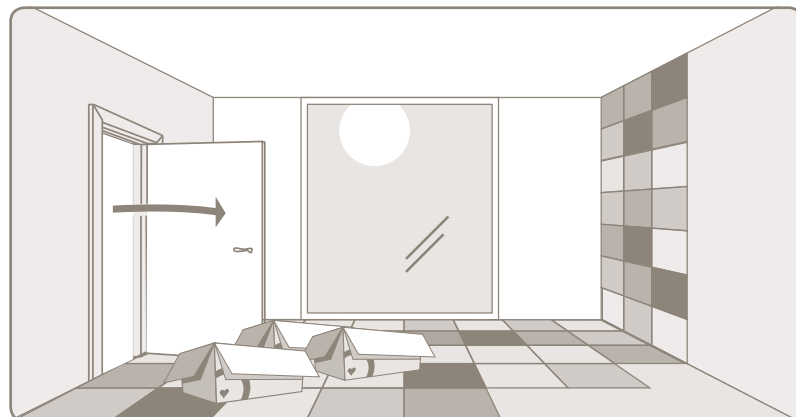

02

O MATERIAL

Para obter um melhor efeito visual do produto, aconselha-se a utilização, alternada, de peças cerâmicas retiradas de várias embalagens em simultâneo. Caso o produto seja destonalizado ou tenha gráfica e tonalidade diferente, deverá ser aplicado de forma aleatória.

MATERIAL

For a better visual effect of the product, it is advisable to use alternating ceramic pieces taken from various packages simultaneously. If the product has shade variations or has different graphics and shades, it should be applied randomly.

LE MATÉRIAU

Pour obtenir un meilleur effet visuel avec le produit, il est conseillé d'utiliser de forme alternée des pièces céramiques retirées simultanément de plusieurs emballages. Si le produit est dénuancé ou a un aspect graphique différent et une tonalité différente, il devra être appliqué de forme aléatoire.

DAS MATERIAL

Damit Sie das beste Ergebnis erzielen, ist es ratsam, die Fliesen immer aus verschiedenen Paketen zu wählen und in regelmäßig abwechselnder Folge zu verlegen. Falls das Produkt diverse Farbschattierung, einen unterschiedliche Farbton oder grafisches Design aufweist, müssen die Fliesen auf diese Weise verlegt werden.

МАТЕРИАЛ

Для получения лучшего визуального эффекта советуем использовать попеременно керамические образцы, беря их из разных коробок одновременно. Если продукция без оттенков или с различающимися графическими изображениями и тональностью, установка должна осуществляться в произвольном порядке.

Technical Information
Information Technique
Technische Information
Техническая Информация

INFORMAÇÃO TÉCNICA

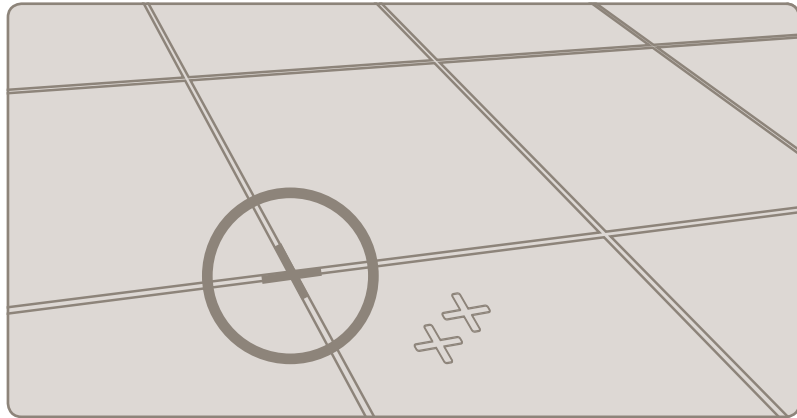

03

≥ 2MM ≥ 2MM 3-5MM

JUNTAS DE ASSENTAMENTO

Tendo em vista uma perfeita aplicação das peças cerâmicas, deve usar-se obrigatoriamente juntas de assentamento. Estas cumprem importantes funções estéticas e técnicas, facilitando o alinhamento dos materiais, absorvendo eventuais deformações que se possam fazer sentir na estrutura – chão e parede – e impedindo, assim, a transmissão destas deformações às peças cerâmicas.

Utilizar as juntas mínimas recomendadas de forma a garantir um bom aspeto estético das peças cerâmicas, bem como respeitar as normas de aplicação:

NÃO RETIFICADOS - junta mínima de 2 mm

RETIFICADO - junta mínima de 2 mm

PRODUTOS RÚSTICOS - 3 – 5 mm

NOTA: independentemente dos valores aqui apresentados, o aplicador deverá sempre seguir as normativas dos países onde está a fazer este trabalho de aplicação.

JOINTS FOR TILE-LAYING

For a perfect application of the ceramic pieces, you should definitely use joints. They fulfill important aesthetic and technical functions, facilitating alignment of the materials, absorbing any possible deformation liable to be felt in the structure - floor and wall - thus preventing the transmission of deformations to the ceramic pieces.

Use the minimum recommended joints so as to ensure a good aesthetic aspect of the ceramic pieces, and respect the rules of application as follows:

NON RECTIFIED - minimum joint of 2mm

RECTIFIED - minimum joint of 2mm

RUSTIC PRODUCTS - 3-5mm

NOTE: Regardless of the values presented here, the person applying it should always follow the regulations of the countries where he is doing this application work.

JOINTS DE POSE

L'utilisation de joints de pose est obligatoire afin d'obtenir une pose parfaite des pièces céramiques. Ils remplissent une importante fonction esthétique et technique. Ils facilitent l'alignement des matériaux et absorbent d'éventuelles déformations qui peuvent se produire dans la structure – sols et murs – et empêchent donc la transmission de ces déformations aux pièces céramiques.

Utiliser Les joints minimaux recommandés afin de garantir un bon aspect esthétique des pièces céramiques et respecter les normes d'application sont les suivants:

NON RECTIFIÉS - joint minimal de 2 mm

RECTIFIÉ - joint minimal de 2 mm

PRODUITS RUSTIQUES - 3 – 5 mm

REMARQUE: Indépendamment des valeurs ici présentées, l'applicateur devra toujours suivre les réglementations du pays où il réalise ce travail d'application.

DAS VERFUGEN

Um die keramischen Platten perfekt zu verlegen, sollten Sie die Wand oder den Boden ordnungsgemäß verfugen. Die Fugen haben wichtige ästhetische und technische Funktionen. Sie erleichtern das Aufreihen der Fliesen; sie absorbieren eventuelle Verformungen der Wand oder des Bodens, und vermeiden dadurch die Übertragung dieser Verformungen auf die Fliesen. Die empfohlenen Fugenbreiten, welche eine schöne Optik sowie eine regelgerechte Verlegung gewährleisten, sind nachfolgend angegeben:

NICHT REKTIFIZIERT – mindestens 2 mm

REKTIFIZIERT – mindestens 2 mm

RUSTISCHE FLIESEN – 3 – 5 mm

WICHTIG: Abgesehen von den oben angegebenen Fugenbreiten, muss der Fliesenleger immer den jeweils geltenden landesspezifischen Vorschriften Folge leisten.

ПРОКЛАДКИ

Для получения безукоризненного результата при установке керамических деталей следует обязательно использовать прокладки. Они играют важную эстетическую и техническую роль, облегчая выравнивание материала, вбирая в себя возможную деформацию, которая может чувствоваться в структуре (пола и стены), препятствуя, таким образом, передаче этой деформации керамическим деталям.

Использовать рекомендуемые минимальные прокладки, чтобы обеспечить отличный эстетический вид керамических деталей, а также соблюдать правила установки:

НЕРЕКТИФИЦИРОВАННАЯ – минимальная прокладка 2 мм

РЕКТИФИЦИРОВАННАЯ – минимальная прокладка 2 мм

ПРОДУКЦИЯ В ДЕРЕВЕНСКОМ СТИЛЕ – 3-5 мм

ПРИМЕЧАНИЕ: Независимо от приведённых здесь значений, специалист всегда должен соблюдать нормы той страны, в которой производит работы по укладке.

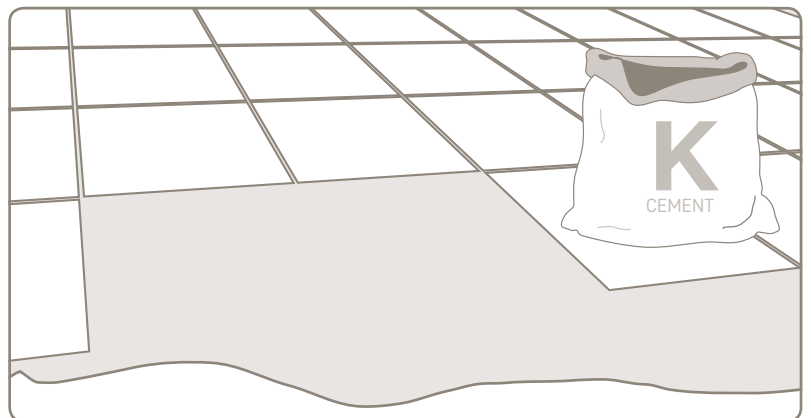

04

COLA E ARGAMASSAS

As argamassas, argamassas de rejuntamento, cimentos-colas e colas a utilizar deverão ter em conta o suporte e o fim a que se destinam as peças cerâmicas - interior, exterior, parede, pavimento - e a sua tipologia - monoporosa ou grés esmaltado. Deverá seguir as instruções indicadas pelo fabricante sobre a sua utilização.

GLUE AND MORTAR

The mortars, grouting mortars, glue-cements, and glues to be used should take into account both the support and the intended purpose of the ceramic pieces - indoor, outdoor, wall, floor - and their typology - mono-porous / monoporosa or glazed stoneware.

You should follow the instructions provided by the manufacturer on its use.



COLLE ET MORTIERS

Les mortiers, mortiers de rejointoiement, ciments-colles et colles à utiliser devront tenir compte du support et de la fin à laquelle sont destinées les pièces céramiques - intérieur, extérieur, mur, plancher - ainsi que de leur typologie - monoporosa ou grès émaillé. Vous devrez suivre les instructions indiquées par le fabricant pour son utilisation.

KLEBER UND MÖRTEL

Welchen Mörtel, welchen Zementkleber oder welche andere Verbundmittel Sie am besten verwenden, hängt sowohl vom Untergrund als auch vom Material (Monoporosa, glasierte Fliesen) ab. Es kommt ebenso darauf an, ob die Fliesen im Außen- oder Innenbereich, an der Wand oder am Boden verlegt werden. Bitte befolgen Sie die Herstellerangaben zum Gebrauch des Produktes.

КЛЕИ И РАСТВОРЫ

При выборе растворов, тампонажных растворов, цементных клеев и других видов клея необходимо учитывать основу и назначение керамических деталей – наружное, внутреннее, стены, напольное покрытие – и его типологию – монопористый или эмалированный керамогранит. Необходимо соблюдать инструкции по их применению, разработанные производителем.

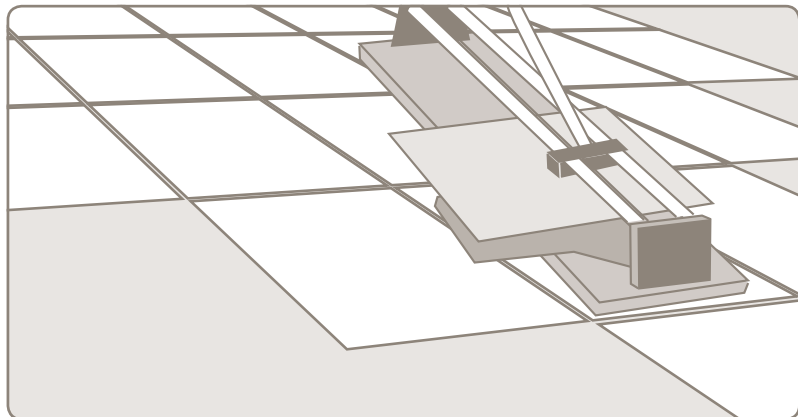

05

CORTE

Para executar cortes nas peças cerâmicas poderá utilizar uma máquina de corte manual. Para cortes mais difíceis poderá utilizar uma máquina de serra de corte com arrefecimento à água com potência superior 1 cv. Também é possível a utilização de rebarbadora de corte a seco para pequenos cortes.

CUT

To make cuts in ceramic pieces you can use a manual cutting machine. For tougher cuts you can use a cutting saw machine with water cooling with power above 1hp. You can also use a dry grinder for making small cuts.

COUPE

Pour couper les pièces céramiques, vous pourrez utiliser une machine de coupe manuelle. Pour des coupes plus difficiles, vous pourrez utiliser une machine de coupe refroidie à eau, d'une puissance supérieure à 1 cv. Il est également possible d'utiliser une meuleuse (coupe à sec) pour les petites découpes.

FLIESEN SCHNEIDEN

Die keramischen Platten können mit Hilfe einer handlichen Fliesenschneidmaschine zugeschnitten werden. Für aufwendige Schnitte können Sie einen Wasser-Fliesenschneider (> 1cv) verwenden. Für kleine Schnitte empfehlen wir einen Winkelschleifer zu benutzen.

РЕЗКА

Чтобы производить резку керамических изделий, можно использовать инструмент для ручной резки. Для более трудоёмкой резки можно применять механическую пилу с водяным охлаждением мощностью свыше 1 л.с. Также при небольшой нарезке возможно применение шлифовальной машины для сухой резки.

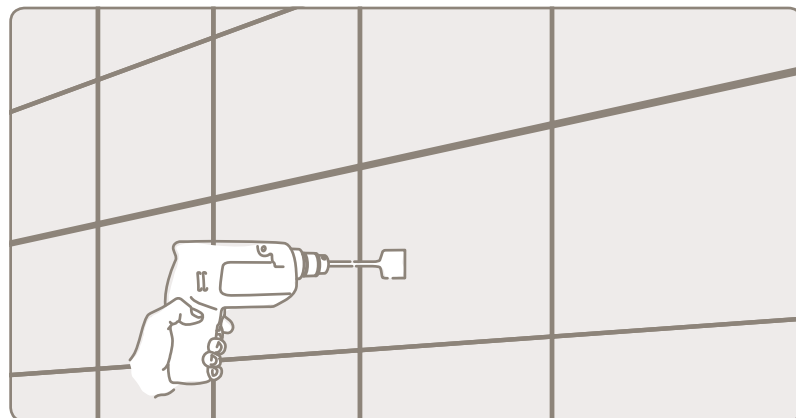

06

FUROS

Na furação deverão ser utilizadas brocas cranianas diamantadas com diâmetro adaptável ao furo pretendido.

HOLES

For drilling you should use diamond twist drills with a diameter adaptable to the desired hole.

PERÇAGES

Pour le perçage, utiliser des trépan diamantés avec un diamètre adapté au trou désiré.

LÖCHER

Löcher sollten im gewünschten Durchmesser mittels einer Diamanthammerbohrkrone in die Fliese gebohrt werden.

ОТВЕРСТИЯ

При сверлении отверстий необходимо использовать алмазные свёрла диаметра, соответствующего предполагаемому отверстию.

Technical Information
Information Technique
Technische Information
Техническая Информация

INFORMAÇÃO TÉCNICA



07

SEGURANÇA NA PREPARAÇÃO E ASSENTAMENTO DO MATERIAL

Aconselha-se a utilização de EPI (equipamento de proteção individual) adequado, nomeadamente, calçado de segurança, luvas de proteção e ainda óculos e proteção auditiva nas operações de corte do material.

Devem ser cumpridas as boas práticas a nível do levantamento e transporte manual de cargas.

SAFETY AND PREPARATION FOR LAYING THE MATERIAL

We advise the use of appropriate PPE (personal protective equipment), namely safety footwear, protective gloves and even goggles (safety glasses) and hearing protection in operations of cutting material.

Good practices must be followed in terms of lifting and carrying loads.

SÉCURITÉ LORS DE LA PRÉPARATION ET DE LA POSE DU MATÉRIAU

Il est conseillé d'utiliser un EPI (équipement de protection individuelle) approprié, notamment des chaussures de sécurité, des gants de protection, mais aussi des lunettes et une protection auditive lors des opérations de coupe du matériau.

Respectez les bonnes pratiques concernant le levage et le transport manuel de charges devront être appliquées.

SICHERHEITSHINWEISE FÜR DAS VERLEGEN VON FLIESEN

Wir empfehlen Ihnen, immer die passende Schutzkleidung zu tragen. Wir ermahnen Sie eindringlich, Schutzschuhe, -handschuhe, -brille sowie Gehörschutz zu benutzen, wenn Sie die Fliesen zuschneiden.

Achten Sie bitte auf die richtige Körperhaltung, wenn Sie Lasten heben und tragen.

ОХРАНА ТРУДА ПРИ ПОДГОТОВКЕ И УКЛАДКЕ МАТЕРИАЛА

Рекомендуется использование подходящих СИЗ (средств индивидуальной защиты), а именно, безопасной обуви, защитных перчаток, а также очков и средств звуковой защиты при резке материала.

Необходимо соблюдать правила безопасности при ручном подъеме и транспортировке грузов.



08

PROTEÇÃO E LIMPEZA

Imediatamente após o assentamento do material cerâmico recomenda-se que as peças cerâmicas sejam devidamente protegidas. Para remoção de sujidade pós-obra, tais como resto de junta, cimentos, etc, recomenda-se a utilização de um ácido desincrustante tamponado para remoção de todos os resíduos.

Na manutenção diária poderão ser utilizados detergentes comuns, respeitando as diluições recomendadas pelo respetivo fabricante.

Relativamente às peças decoradas, dever-se-á evitar a utilização de produtos de limpeza abrasivos, poderão danificar as peças.

As peças decoradas através da deposição de partículas de titânio – designação "mirror" - que lhe conferem um aspeto metálico deverão ser manuseadas com cuidado. A limpeza final e de manutenção deste tipo de produto deverá ser feita com detergentes próprios para metais – brilhantador de aço inox - de forma a criar um efeito antiestático que possa repelir a sujidade e proteger o produto de gorduras e corrosão.

PROTECTION AND CLEANING

Immediately after the laying of ceramic material it is recommended that the ceramic parts are / will be duly protected. For dirt removal after the work, such as left-over joints, cements, etc., it is recommended that you use a buffered descaling acid to remove all residues.

In daily maintenance, ordinary detergents may be used, respecting the dilutions recommended by the respective manufacturer.

Regarding decorated pieces, you should avoid the use of abrasive cleansers that may damage the pieces.

Pieces decorated through the depositing of titanium particles – with the designation "mirror" - which give them a metallic aspect should be handled with care. The final cleaning and maintenance of this type of product should be made with detergents suitable for metals - stainless steel brightener - so as to create an antistatic effect that can repel dirt and protect the product from fats and corrosion.

PROTECTION ET NETTOYAGE

Immédiatement après la pose du matériau céramique, il est recommandé de protéger correctement les pièces céramiques. Pour l'élimination de la saleté résultant des travaux, comme les résidus de joints, ciments, etc., il est recommandé d'utiliser un acide tamponné désincrustant. L'entretien quotidien pourra être réalisé avec des détergents ordinaires, en respectant les dilutions recommandées par le fabricant respectif.

Pour les pièces décorées, l'utilisation de produits de nettoyage abrasifs devra être évitée car ils pourront endommager les pièces.

Les pièces décorées grâce au dépôt de particules de titane – désignation « mirror » - qui lui confèrent un aspect métallique, devront être manipulées avec soin. Le nettoyage final et d'entretien de ce type de produit devra être réalisé avec des détergents spécifiques pour les métaux – agent de brillantage d'acier inox - afin de créer un effet antistatique qui puisse repousser la saleté et protéger le produit des graisses et de la corrosion.



LOVE
CERAMIC TILES

Technical Information
Information Technique
Technische Information
Техническая Информация

INFORMAÇÃO TÉCNICA

SCHUTZ UND REINIGUNG

Bitte vergessen Sie nicht sofort nach Beendigung der Verlegearbeiten, die verflieste Fläche ordnungsgemäß zu schützen. Waschen Sie die verflieste Fläche mit Säure um etwaigen Schmutz (wie z.B.: Schlieren vom Fugenmaterial, Zement, etc.) zu beseitigen.

Für die alltägliche Pflege empfehlen wir die Verwendung von handelsüblichen Reinigungsmitteln. Beachten Sie bitte die Verdünnungsanweisung des Herstellers des Produktes.

Die Pflege und die Reinigung der keramischen Platten ist sehr einfach und sollte mit neutralen Putzmitteln durchgeführt werden.

Bitte befolgen Sie die Herstellerangaben zum Gebrauch des Produktes.

Schleifmittel können zur Beschädigung der Dekore führen und sind daher zu vermeiden.

Die Dekore „Mirror“, auf die Titanpartikeln aufgetragen werden und dadurch der Fliese einen metallartigen Anschein verleihen, sind empfindlich.

Die Reinigung sowie Pflege dieser Produktsart müssen mit speziellen Metallreinigungsmitteln durchgeführt werden – wie z.B.: Klarspülmittel für Edelstahl.

Diese sorgen für einen antistatischen Effekt, welcher den Schmutz abstößt und zusätzlich das Produkt von Fett und Korrosion schützt.

ЗАЩИТА И ЧИСТКА

Непосредственно после укладки керамического материала рекомендуется принять меры по защите керамических изделий. После удаления загрязнений, возникших в ходе работы, таких как излишки прокладки, цементирования, и тд., рекомендуется использовать буферную кислоту для удаления всех остатков.

В повседневной чистке можно использовать обычные моющие средства, соблюдая нормы разбавления, указанные изготовителем.

В том, что касается декорированных деталей, следует избегать использование абразивных моющих средств, поскольку они могут повредить детали.

С деталями, декорированными путем осаждения титановых частиц – “зеркальная плитка”, придающих им металлический вид, необходимо обращаться осторожно. Их окончательная и повседневная мойка должна производиться мощными средствами, специально предназначенными для металлов (полирующий состав для нержавеющей стали), чтобы создать антистатический эффект для отражения грязи и защиты продукции от жирных веществ и коррозии.

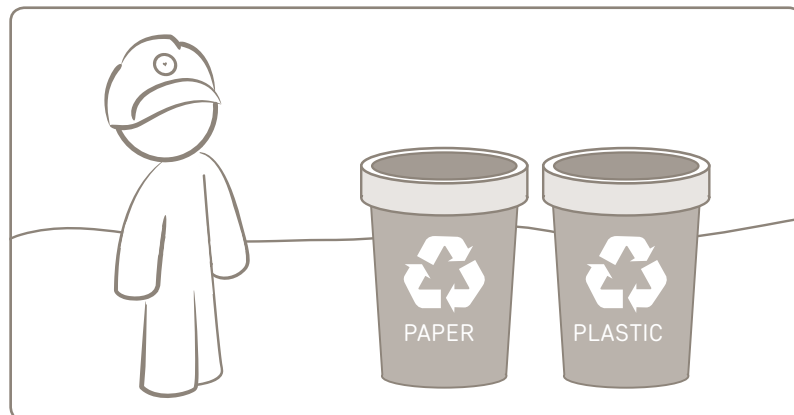

09

GESTÃO DE RESÍDUOS DE EMBALAGEM

Os resíduos das embalagens, de cartão e de plástico, devem ser colocados nos locais disponíveis para a sua posterior valorização, nomeadamente nos Ecopontos ou em sistemas adequados a disponibilizar pela Sociedade Ponto Verde.

PACKAGING WASTE MANAGEMENT

Packaging Waste (cardboard and plastic) should be placed in locations available for subsequent recovery, namely in Eco points or adequate systems to be provided by specific companies.

GESTION DES DÉCHETS D'EMBALLAGE

Les déchets d'emballages, de carton et de plastique doivent être placés dans les lieux disponibles pour leur valorisation postérieure, notamment les écopoints ou les systèmes appropriés mis à disposition par des entreprises spécifiques.

ENTSORGUNG VON VERPACKUNGSMATERIAL

Der Verpackungsabfall, sowohl Papier als auch Plastik, muss an angemessenen Standorten zur Weiterverwertung entsorgt werden, welche beauftragte Unternehmen dafür zur Verfügung stellen.

ОБРАЩЕНИЕ С УПАКОВОЧНЫМИ ОТХОДАМИ

Использованный картонный и пластиковый упаковочный материал должен складываться в местах, предусмотренных для их последующей утилизации, а точнее в экопунктах или в соответствующих пунктах, обустроенных специализированными предприятиями.

Technical Features
 Caractéristiques Techniques
 Technische Eigenschaften
 Технические Характеристики

CARACTERÍSTICAS TÉCNICAS

REVESTIMENTO MONOPOROSA

Single Fired Wall Tiles | Faïences Monocuisson | Weisscherbige | Плитка Облицовочная Однократного Обжига

EN14411: ANEXO | ANNEX | ANNEXE | ANHANG | ПРИЛОЖЕНИЕ K GRUPO | GROUP | GROUPE | GRUPE | КЛАСС VIII
 ISO 13006: ANEXO | ANNEX | ANNEXE | ANHANG | ПРИЛОЖЕНИЕ L GRUPO | GROUP | GROUPE | GRUPE | КЛАСС VIII

SIMBOLOGIA SYMBOLS SYMBOLES ZEICHEN СИМВОЛИКА	CARACTERÍSTICAS FEATURES CARACTÉRISTIQUES EIGENSCHAFTEN ХАРАКТЕРИСТИКИ	NORMA TEST METHOD METHODE D'ESSAI PRUEFMETHODE НОРМА	VALOR PRESCRITO PRESCRIBED VALUE VALEUR PRESCRITE VORGESCHRIEB. WERT ЗАЯВЛЕННЫЙ ОБЪЁМ	LOVE CERAMIC TILES	
	Comprimento e largura Length and width Longueur et largeur Laenge und breite Длина и ширина	EN ISO 10545-2	± 0,5% (máx ± 2,0 mm)	garantido guaranted garanti sichergestellt гарантия	
	Espessura Thickness Épaisseur Dicke Толщина		± 10% (máx ± 0,5 mm)	garantido guaranted garanti sichergestellt гарантия	
	Medida da rectilinearidade das arestas Side straightness Rectitude des arêtes Feradlinigkeit der kanten Прямолинейность лицевых граней		± 0,3% (máx ± 1,5 mm)	garantido guaranted garanti sichergestellt гарантия	
	Medida da ortogonalidade Rectangularity Angularité Rechtwinkligkeit der kanten Ортогональность (кривизна сторон)		± 0,5% (máx ± 2,0 mm)	garantido guaranted garanti sichergestellt гарантия	
	Medida da planariedade Flatness Planéité Ebeflaechigkeit Планирность (кривизна поверхности)		Curv. Central e lateral Center and edge curvature Courbe centrale et latérale Zentrierte und seitliche biegung Центральная и боковая кривизна	+ 0,5% (máx + 2,0mm) - 0,3% (máx - 1,5 mm)	garantido guaranted garanti sichergestellt гарантия
			Empeno Warpage Gauchissement Krummung Искривление	± 0,5% (máx ± 2,0 mm)	
	Absorção de água Water absorption Absorption d'eau Wasseraufnahme Водопоглощение	EN ISO 10545-3	E > 10%	13%-18%	
	Resistência à flexão Resistance to bending Résistance à la flexion Biegefestigkeit Сопротивление на изгиб	EN ISO 10545-4	> 7,5 mm	≥ 12 N/mm ²	≥ 18 N/mm ²
			= 7,5 mm		≥ 16 N/mm ²
	Força de ruptura Breaking strenght Force de rupture Bruchfestigkeit Твёрдость	EN ISO 10545-4	≥ 7,5 mm	≥ 600 N	≥ 600 N
	Coeficiente de expansão térmica linear Coefficient of linear thermal expansion Coefficient d'extension thermique linéaire Linearer waermeausdehn.Koeff Коэффициент линейного термического	EN ISO 10545-8	segundo os valores do fabricante according to manufacturer requirements selon les valeurs du fabricant Laut Werte des Herstellers согласно данным производителя	75x10 ⁻⁷ °C ⁻¹ valor máximo maximum value valeur maximum Maximalwert максимальные показатели	
	Resistência ao choque térmico Thermal shock resistance Résistance aux chocs thermiques Temperaturwechsel bestaendigkeit Устойчивость к температурным перепадам	EN ISO 10545-9	exigido required demandé Anforderung востребовано	garantido guaranted garanti sichergestellt гарантия	
	Resistência ao fendilhamento Crazing resistance Résistance aux trésaillures Haarrisse bestaendigkeit Устойчивость к растрескиванию	EN ISO 10545-11	exigido required demandé Anforderung востребовано	garantido guaranted garanti sichergestellt гарантия	
	Resistência ao gelo Frost resistance Résistance au gel Frost bestaendigkeit Морозоустойчивость	EN ISO 10545-12	exigido required demandé anforderung востребовано	garantido guaranted garanti sichergestellt гарантия	
	Resistência aos ácidos e bases Resistance against acids and alkalis Résistance aux acides et aux alcalis Bestaend. Gegen saeuren u. Laugen Устойчивость к воздействию кислот и щелочей	EN ISO 1045-13	segundo os valores do fabricante according to manufacturer requirements selon les valeurs du fabricant Laut Werte des Herstellers согласно данным производителя	mínimo: GLB minimum: GLB mínimum: GLB minimum: GLB	
	Resistência aos produtos de limpeza domésticos Resistance to household cleaning products Résistance aux produits domestiques de nettoyage Bestaendig. G Haushaltsreinigungsprodukte Устойчивость к бытовой химии		mínimo: GB minimum: GB mínimum: GB minimum: GB	classe GA class GA classe GA classe GA класс GA	
	Resistência às manchas Resistance to staining Résistance aux taches Bestaendigkeit gegen flecken Устойчивость к появлению пятен	EN ISO 10545-14	mínimo: classe 3 minimum: class 3 mínimum: classe 3 minimum: classe 3 минимум: класс 3	mínimo: classe 4 minimum: class 4 mínimum: classe 4 minimum: classe 4 минимум: класс 4	



GRÉS VIDRADO

Glazed Porcelain Tiles | Grès Cérame Émaillé | Feinsteinzeug Glasiert | Керамогранит Глазурованный















EN14411: ANEXO | ANNEX | ANNEXE | ANHANG | ПРИЛОЖЕНИЕ **G** GRUPO | GROUP | GROUPE | GRUPPE | КЛАСС **BIA**
ISO 13006: ANEXO | ANNEX | ANNEXE | ANHANG | ПРИЛОЖЕНИЕ **G** GRUPO | GROUP | GROUPE | GRUPPE | КЛАСС **BIA**





SIMBOLOGIA SYMBOLS SYMBOLES ZEICHEN СИМВОЛИКА	CARACTERÍSTICAS FEATURES CARACTÉRISTIQUES EIGENSCHAFTEN ХАРАКТЕРИСТИКИ	NORMA TEST METHOD MÉTHODE D'ESSAI PRUEFMETHODE НОРМА	VALOR PRESCRITO PRESCRIBED VALUE VALEUR PRESCRITE VORGESCHRIEB. WERT ЗАЯВЛЕННЫЙ ОБЪЁМ	LOVE CERAMIC TILES
	Comprimento e largura Length and width Longueur et largeur Laenge und breite Длина и ширина	EN ISO 10545-2	± 0,6% (máx ± 2,0 mm)	garantido guaranted garanti sichergestellt гарантия
	Espessura Thickness Épaisseur Dicke Толщина		± 5% (máx ± 0,5 mm)	garantido guaranted garanti sichergestellt гарантия
	Medida da rectilinearidade das arestas Side straightness Rectitude des arêtes Feradlingigkeit der kanten Прямолинейность лицевых граней		± 0,5% (máx ± 1,5 mm)	garantido guaranted garanti sichergestellt гарантия
	Medida da ortogonalidade Rectangularity Angularité Rechtwinkligkeit der kanten Ортогональность (кривизна сторон)		± 0,5% (máx ± 2,0 mm)	garantido guaranted garanti sichergestellt гарантия
	Medida da planariedade Flatness Planéité Ebenaechtigkeit Планирность (кривизна поверхности)		± 0,5% (máx ± 2,0mm)	garantido guaranted garanti sichergestellt гарантия
	Absorção de água Water absorption Absorption d'eau Wasseraufnahme Водопоглощение	EN ISO 10545-3	E ≤ 0,5%	E ≤ 0,2%
	Resistência à flexão Resistance to bending Résistance à la flexion Biegefestigkeit Спротивление на изгиб	Modulo de ruptura Modulus of ruture Module de rupture Biegung modul Предел прочности на изгиб	≥ 35 N/mm ²	≥ 35 N/mm ²
		Força de ruptura Breaking strenght Force de rupture Bruchfestigkeit Твёрдость	≥ 1300 N	≥ 1300 N
	Resistência à abrasão Résistance à l'abrasion Abrasion resistance Abrieb widerstand Устойчивость	EN ISO 10545-7	segundo os valores do fabricante according to manufacturer requirements selon les valeurs du fabricant Laut Werte des Herstellers согласно данным производителя	2 - 5
	Coefficiente de expansão térmica linear Coefficient of linear thermal expansion Coefficient d'extension thermique linéaire Linearer waermeausdehn.Koeff Коэффициент линейного термического	EN ISO 10545-8	segundo os valores do fabricante according to manufacturer requirements selon les valeurs du fabricant Laut Werte des Herstellers согласно данным производителя	75x10 ⁻⁷ °C ⁻¹ valor máximo maximum value valeur maximum Maximalwert максимальные показатели
	Resistência ao choque térmico Thermal shock resistance Résistance aux chocs thermiques Temperaturwechsel bestaendigkeit Устойчивость к температурным перепадам	EN ISO 10545-9	exigido required demandé Anforderung востребовано	garantido guaranted garanti sichergestellt гарантия
	Resistência ao fendilhamento Crazing resistance Résistance aux trésaillures Haarrisse bestaendigkeit Устойчивость к растрескиванию	EN ISO 10545-11	exigido required demandé Anforderung востребовано	garantido guaranted garanti sichergestellt гарантия
	Resistência ao gelo Frost resistance Résistance au gel Frost bestaendigkeit Морозоустойчивость	EN ISO 10545-12	exigido required demandé Anforderung востребовано	garantido guaranted garanti sichergestellt гарантия
	Resistência aos ácidos e bases Resistance against acids and alkalis Résistance aux acides et aux alcalis Bestaend. Gegen saeuren u. Laugen Устойчивость к воздействию кислот и щелочей	EN ISO 1045-13	segundo os valores do fabricante according to manufacturer requirements selon les valeurs du fabricant Laut Werte des Herstellers согласно данным производителя	mínimo: GLB minimum: GLB minimum: GLB minimum: GLB минимум: GLB
	Resistência aos produtos de limpeza domésticos Resistance to household cleaning products Résistance aux produits domestiques de nettoyage Bestaendig. G.Haushaltsreinigungsmittel Устойчивость к бытовой химии		mínimo: GB minimum: GB minimum: GB minimum: GB минимум: GB	classe GA class GA classe GA classe GA класс GA
	Resistência às manchas Resistance to staining Résistance aux taches Bestaendigkeit gegen flecken Устойчивость к появлению пятен	EN ISO 10545-14	mínimo: classe 3 minimum: class 3 minimum: classe 3 minimum: klasse 3 минимум: класс 3	mínimo: classe 4 minimum: class 4 minimum: classe 4 minimum: klasse 4 минимум: класс 4

Technical Information
 Information Technique
 Technische Information
 Техническая Информация
INFORMAÇÃO TÉCNICA

SIMBOLOGIA

Symbols | Symboles | Zeichen | Символика

	Revestimento com acabamento mate ou semi-brilho Matt or semi-gloss wall tiles Faïences en finition mat ou semi-brillant. Wandfliesen - matt oder halbmatt oberfläche Настенная керамическая плитка с матовым или полу-глянцевым покрытием
	Revestimento com acabamento brilho Glossy wall tiles Faïences avec finition brillant Wandfliesen - glänzend oberfläche Настенная керамическая плитка с глянцевым покрытием
	Revestimento estruturado com acabamento mate ou semi-brilho Matt or glossy structured wall tiles Faïences structuré en finition mat ou semi-brillant Strukturierte wandfliesen - matt oder halbmatt oberfläche Настенная структурированная плитка с матовым или полу-глянцевым покрытием
	Revestimento estruturado com acabamento brilho Glossy structured wall tiles Faïences structuré en finition brillant Strukturierte wandfliesen - glänzend oberfläche Настенная структурированная плитка с глянцевым покрытием
	Pavimento com acabamento mate ou semi-brilho Matt or glossy floor tiles Carreaux sol en finition mat ou semi-brillant. Bodenfliesen - matt oder halbmatt oberfläche Напольная плитка с матовым или полу-глянцевым покрытием
	Pavimento com acabamento brilho ou satinado Floor tiles with bright or honed finish Revêtement de sol avec finition brillante ou satinée Bodenbelag mit glänzender oder matter oberfläche Поверхность с глянцевым или матовым покрытием
	Pavimento com acabamento polido Floor tiles with polished finish Revêtement de sol avec finition polie Bodenbelag mit polierter oberfläche Полированная поверхность
	Anti-derrapante (DIN 51097) Non-slippery (DIN 51097) Antidérapant (DIN 51097) Rutschfest (DIN 51097) Противоскользящий (DIN 51097)
	Anti-derrapante (DIN 51130) Non-slippery (DIN 51130) Antidérapant (DIN 51130) Rutschsicher (DIN 51130) Противоскользящий (DIN 51130)
	Pavimento e revestimento Floor and wall tiles Faïences et carreaux sol Wandfliesen und bodenfliesen Плитка облицовочная и напольная
	Acabamento brilho Glossy finishing Finition brillant Glanz oberfläche Глянцевое покрытие
	Produto com gráfica e tonalidade diferente Product with different graphics and shades Produit ayant une sérigraphie et une tonalité différente Produkt mit verschiedener grafik und tönung Издлия различной текстуры и оттенков
	Espessura Thickness Épaisseur Dicke Толщина
	Decorações/peças especiais vendidas a m² Decorations/ special pieces sold per m² Décorations/pièces spéciales vendues au m² Dekorationen/sonderposten verkauft pro m² Декорации/специальные изделия продаваемые по м²
	40% Desconto adicional 40% De remise extra 40% Extra-rabatt 40% Дополнительная скидка

	Destonização nula Shade variation none Non dénuancé Farbspiel null Различия отсутствуют
	Destonização ligeira Shade variation slight Légèrement dénuancé Farbspiel gering Минимальные различия
	Destonização baixa Shade variation low Peu dénuancé Farbspiel mittel Небольшие различия
	Destonização média Shade variation moderate Moyennment dénuancé Farbspiel stark Средние различия
	Destonização alta Shade Variation high Fortement dénuancé Farbspiel sehr stark Большие различия

PEÇAS ESPECIAIS

Special Pieces | Pièces Spéciales | Spezialteile | Специальные Элементы

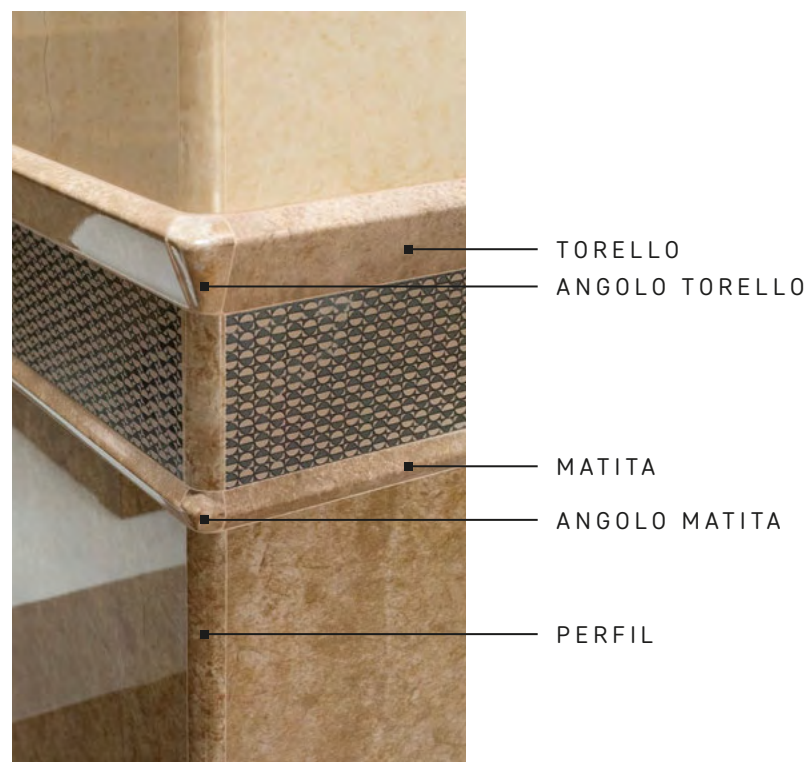



Technical Information
Information Technique
Technische Information
Техническая Информация

INFORMAÇÃO TÉCNICA

DESIGNAÇÃO DESIGNATION DÉSIGNATION BEZEICHNUNG ОБОЗНАЧЕНИЕ	FORMATO SIZE FORMAT FORMAT РАЗМЕР	ESPESSURA THICKNESS ÉPAISSEUR DICKE ПРОДУКТ	
ESSENCE			
ESSENCE ANTRACITE	33,3 x 33,3	7,8 mm	U2 P3 E3 C2
ESSENCE BROWN	33,3 x 33,3	7,8 mm	U2 P3 E3 C2
ESSENCE GREY	33,3 x 33,3	7,8 mm	U2 P3 E3 C2
ESSENCE LIGHT GREY	33,3 x 33,3	7,8 mm	U3 P3 E3 C2
ESSENCE TORTORA	33,3 x 33,3	7,8 mm	U3 P3 E3 C2
ESSENCE WHITE	33,3 x 33,3	7,8 mm	U2 P3 E3 C2
FEVER			
FEVER BURN GREY	45 x 45	9 mm	U2S P3 E3 C2
FEVER DEEP DARK	45 x 45	9 mm	U2 P3 E3 C2
FEVER HOT BLACK	45 x 45	9 mm	U2 P3 E3 C2
FEVER INTENSE WHITE	45 x 45	9 mm	U3 P3 E3 C2
FEVER SPICY BROWN	45 x 45	9 mm	U2 P3 E3 C2
VISION			
VISION GREY	45 x 45	9 mm	U2 P3 E3 C2
VISION LIGHT GREY	45 x 45	9 mm	U2S P3 E3 C2
VISION WHITE	45 x 45	9 mm	U3 P3 E3 C2
GROUND			
GROUND CREAM	30 x 60	8 mm	U3 P3 E3 C2
GROUND GREY	30 x 60	8 mm	U2S P3 E3 C2
GROUND LIGHT GREY	30 x 60	8 mm	U2 P3 E3 C2
GROUND TORTORA	30 x 60	8 mm	U2S P3 E3 C2
GROUND WHITE	30 x 60	8 mm	U3 P3 E3 C2
GROUND CREAM	45 x 45	8 mm	U3 P3 E3 C2
GROUND GREY	45 x 45	8 mm	U2S P3 E3 C2
GROUND LIGHT GREY	45 x 45	8 mm	U2 P3 E3 C2
GROUND TORTORA	45 x 45	8 mm	U2S P3 E3 C2
GROUND WHITE	45 x 45	8 mm	U3 P3 E3 C2
GROUND CREAM	59,2 x 59,2 RET.	9 mm	U3 P3 E3 C2
GROUND GREY	59,2 x 59,2 RET.	9 mm	U2S P3 E3 C2
GROUND LIGHT GREY	59,2 x 59,2 RET.	9 mm	U2 P3 E3 C2
GROUND TORTORA	59,2 x 59,2 RET.	9 mm	U2S P3 E3 C2
GROUND WHITE	59,2 x 59,2 RET.	9 mm	U3 P3 E3 C2
GROUND CREAM	60 x 60	9 mm	U3 P3 E3 C2
GROUND GREY	60 x 60	9 mm	U2S P3 E3 C2
GROUND LIGHT GREY	60 x 60	9 mm	U2 P3 E3 C2
GROUND TORTORA	60 x 60	9 mm	U2S P3 E3 C2
GROUND WHITE	60 x 60	9 mm	U3 P3 E3 C2

DESIGNAÇÃO DESIGNATION DÉSIGNATION BEZEICHNUNG ОБОЗНАЧЕНИЕ	FORMATO SIZE FORMAT FORMAT РАЗМЕР	ESPESSURA THICKNESS ÉPAISSEUR DICKE ПРОДУКТ	
SOUL			
SOUL BODY BLACK	33,3 x 33,3	9 mm	U2 P3 E3 C2
SOUL FEEL WHITE	33,3 x 33,3	9 mm	U3 P3 E3 C2
SOUL FLOW GREY	33,3 x 33,3	9 mm	U2S P3 E3 C2
SOUL MOTION BEIGE	33,3 x 33,3	9 mm	U2S P3 E3 C2
SOUL PASSION ANTRACITE	33,3 x 33,3	9 mm	U2 P3 E3 C2
SOUL SPIRIT PEARL	33,3 x 33,3	9 mm	U3 P3 E3 C2
SOUL BODY BLACK	50 x 50	9 mm	U2 P3 E3 C2
SOUL FEEL WHITE	50 x 50	9 mm	U3 P3 E3 C2
SOUL FLOW GREY	50 x 50	9 mm	U2S P3 E3 C2
SOUL MOTION BEIGE	50 x 50	9 mm	U2S P3 E3 C2
SOUL PASSION ANTRACITE	50 x 50	9 mm	U2 P3 E3 C2
SOUL SPIRIT PEARL	50 x 50	9 mm	U3 P3 E3 C2
PLACE			
PLACE ANTRACITE	45 x 45	9 mm	U2 P3 E3 C2
PLACE GREY	45 x 45	9 mm	U2 P3 E3 C2
PLACE LIGHT GREY	45 x 45	9 mm	U3 P3 E3 C2
PLACE TORTORA	45 x 45	9 mm	U2 P3 E3 C2
PLACE WHITE	45 x 45	9 mm	U3 P3 E3 C2
PLACE ANTRACITE	60 x 60	10 mm	U2 P3 E3 C2
PLACE GREY	60 x 60	10 mm	U2 P3 E3 C2
PLACE LIGHT GREY	60 x 60	10 mm	U3 P3 E3 C2
PLACE TORTORA	60 x 60	10 mm	U2 P3 E3 C2
PLACE WHITE	60 x 60	10 mm	U3 P3 E3 C2
GROUND OFFSHORE			
OFFSHORE CREAM	59,2 x 59,2 RET.	9 mm	U3 P3 E3 C2
OFFSHORE GREY	59,2 x 59,2 RET.	9 mm	U2S P3 E3 C2
OFFSHORE LIGHT GREY	59,2 x 59,2 RET.	9 mm	U3 P3 E3 C2
OFFSHORE TORTORA	59,2 x 59,2 RET.	9 mm	U2S P3 E3 C2
OFFSHORE WHITE	59,2 x 59,2 RET.	9 mm	U3 P3 E3 C2
OFFSHORE CREAM	60 x 60	9 mm	U3 P3 E3 C2
OFFSHORE GREY	60 x 60	9 mm	U2S P3 E3 C2
OFFSHORE LIGHT GREY	60 x 60	9 mm	U3 P3 E3 C2
OFFSHORE TORTORA	60 x 60	9 mm	U2S P3 E3 C2
OFFSHORE WHITE	60 x 60	9 mm	U3 P3 E3 C2

TABELA DE CALIBRES

Calibers | Tableau des calibres | Kaliber | Таблица по калибрам









DIMENSÃO NOMINAL (CM) NOMINAL DIMENSION (CM) DIMENSION NOMINALE (CM) NENNMASS(CM) РАЗМЕР (CM)	B	C	D	E	H	L			
30 X 60	297,0 X 596,1 X 8,0	298,0 X 597,4 X 8,0	299,0 X 598,7 X 8,0	300 X 600 X 8,0	301,0 X 601,3 X 8,0	302,0 X 602,6 X 8,0			
31,4 X 61,2	311,0 X 608,1 X 9,0	312,0 X 609,4 X 9,0	313,0 X 610,7 X 9,0	314,0 X 612,0 X 9,0	315,0 X 613,3 X 9,0	316,0 X 614,6 X 9,0			
33,3 X 33,3	329,4 X 329,4 X 7,8	330,6 X 330,6 X 7,8	331,8 X 331,8 X 7,8	333,0 X 333,0 X 7,8	334,2 X 334,2 X 7,8	335,4 X 335,4 X 7,8			
	329,4 X 329,4 X 9,0	330,6 X 330,6 X 9,0	331,8 X 331,8 X 9,0	333,0 X 333,0 X 9,0	334,2 X 334,2 X 9,0	335,4 X 335,4 X 9,0			
33,3 X 50,0	329,4 X 496,4 X 9,0	330,6 X 497,6 X 9,0	331,8 X 498,8 X 9,0	333,0 X 500,0 X 9,0	334,2 X 501,2 X 9,0	335,4 X 502,4 X 9,0			
36,0 X 36,0	357,0 X 357,0 X 9,0	358,0 X 358,0 X 9,0	359,0 X 359,0 X 9,0	360,0 X 360,0 X 9,0	361,0 X 361,0 X 9,0	362,0 X 362,0 X 9,0			
45,0 X 45,0	445,8 X 445,8 X 8,0	447,2 X 447,2 X 8,0	448,6 X 448,6 X 8,0	450,0 X 450,0 X 8,0	451,4 X 451,4 X 8,0	452,8 X 452,8 X 8,0			
	445,8 X 445,8 X 9,0	447,2 X 447,2 X 9,0	448,6 X 448,6 X 9,0	450,0 X 450,0 X 9,0	451,4 X 451,4 X 9,0	452,8 X 452,8 X 9,0			
50,0 X 50,0	495,8 X 495,8 X 9,0	497,2 X 497,2 X 9,0	498,6 X 498,6 X 9,0	500,0 X 500,0 X 9,0	501,4 X 501,4 X 9,0	502,8 X 502,8 X 9,0			
51,0 X 51,0	505,8 X 505,8 X 9,0	507,2 X 507,2 X 9,0	508,6 X 508,6 X 9,0	510,0 X 510,0 X 9,0	511,4 X 511,4 X 9,0	512,8 X 512,8 X 9,0			
60,0 X 60,0	595,5 X 595,5 X 9,0	597,0 X 597,0 X 9,0	598,5 X 598,5 X 9,0	600,0 X 600,0 X 9,0	601,5 X 601,5 X 9,0	603,0 X 603,0 X 9,0			
	595,5 X 595,5 X 10,0	597,0 X 597,0 X 10,0	598,5 X 598,5 X 10,0	600,0 X 600,0 X 10,0	601,5 X 601,5 X 10,0	603,0 X 603,0 X 10,0			
31,0 X 62,0		308,6 X 618,0 X 10,0	309,3 X 619,0 X 10,0	310,0 X 620,0 X 10,0	310,7 X 621,0 X 10,0	311,4 X 622,0 X 10,0			
15,0 X 75,0		149,7 X 747,4 X 9,0	150,2 X 748,7 X 9,0	150,7 X 750,0 X 9,0	151,2 X 751,3 X 9,0	151,7 X 752,6 X 9,0			
DIMENSÃO NOMINAL (CM) NOMINAL DIMENSION (CM) DIMENSION NOMINALE (CM) NENNMASS(CM) РАЗМЕР (CM)	Q	S	T	X	U	A	V	B	W
60,4 X 60,4	599,2 X 599,2 X 20,0	600,4 X 600,4 X 20,0	601,6 X 601,6 X 20,0	602,8 X 602,8 X 20,0	604,0 X 604,0 X 20,0	605,2 X 605,2 X 20,0	606,4 X 606,4 X 20,0	607,6 X 607,6 X 20,0	608,8 X 608,8 X 20,0

Packing
Emballage
Verpackung
Упаковка

EMBALAGEM









REVESTIMENTOS MONOPOROSA

White Body Wall Tiles | Faïences Monocuisson | Weisscherbige | Плитка Облицовочная Однократного Обжига

FORMATO SIZE FORMAT FORMAT РАЗМЕР	ESPESSURA THICKNESS ÉPAISSEUR DICKE ПРОДУКТ	PEÇAS/M ² PCS/M ² PCS/M ² STK/M ² ШТ/М ²	PESO/M ² WEIGHT/M ² POIDS/M ² GEWICHT/M ² ВЕС/М ²	PZ X 	M ² X 	KG X 	 X 	M ² X 	KG X 	 C A X B X C CM
31 x 62	10 mm	5,20	16,57 Kg	6	1,15	19,10 Kg	40	46,00	764 Kg	80 x 120 x 77
31 x 62	8,5 mm	5,20	14,04 Kg	7	1,35	18,96 Kg	40	54,00	783 Kg	80 x 120 x 77
33,3 x 45	9,0 mm	6,67	15,40 Kg	10	1,50	23,10 Kg	34	51,00	810 Kg	80 x 120 x 81,6
20 x 60	9,0 mm	8,33	13,83 Kg	14	1,68	23,24 Kg	40	67,20	955 Kg	80 x 120 x 95
20 x 60	8,0 mm	8,33	12,92 Kg	15	1,80	23,20 Kg	40	72,00	953 Kg	80 x 120 x 95
22,5 x 45 - FORM	9,0-10,7 mm	9,88	15,40 Kg	13	1,32	21,00 Kg	33	43,60	718 Kg	80 x 120 x 82,5
22,5 x 45	9,0 mm	9,88	15,40 Kg	16	1,62	24,95 Kg	33	53,46	823 Kg	80 x 120 x 82,5
22,5x45 - DIAMOND	9,0 - 12,8 mm	9,88	17,84 Kg	11	1,11	22,80 Kg	33	36,63	760 Kg	80 x 120 x 82,5
22,5x45 - PYRAMID	9,0 - 10,4 mm	9,88	15,69 Kg	14	1,42	22,28 Kg	33	46,86	764 Kg	80 x 120 x 82,5
22,5 x 45	7,5 mm	9,88	11,65 Kg	19	1,92	22,42 Kg	33	63,36	765 Kg	80 x 120 x 82,5
22,5 x 33,3	8,4 mm	13,33	14,00 Kg	20	1,50	21,00 Kg	36	54,00	780 Kg	80 x 120 x 82,5









GRÈS VIDRADO

Porcelain Glazed Floor Tiles | Grès Cérame Émaillé | Feinsteinzeug Glasiert Bodenfliesen | Керамогранит Глазурованный

FORMATO SIZE FORMAT FORMAT РАЗМЕР	ESPESSURA THICKNESS ÉPAISSEUR DICKE ПРОДУКТ	PEÇAS/M ² PCS/M ² PCS/M ² STK/M ² ШТ/М ²	PESO/M ² WEIGHT/M ² POIDS/M ² GEWICHT/M ² ВЕС/М ²	PZ X 	M ² X 	KG X 	 X 	M ² X 	KG X 	 C A X B X C CM
60 x 60	10,0 mm	2,78	22,50 Kg	3	1,08	24,30 Kg	36	38,88	900 Kg	80 x 120 x 75
60 x 60 - GROUND	9,0 mm	2,78	18,74 Kg	3	1,08	20,96 Kg	36	38,88	780 Kg	80 x 120 x 75
51 x 51	9,0 mm	3,85	19,20 Kg	5	1,30	25,78 Kg	28	36,40	146 Kg	80 x 120 x 65
50 x 50	9,0 mm	4,00	19,20 Kg	5	1,25	24,00 Kg	28	35,00	697 Kg	80 x 120 x 65
45 x 45	9,0 mm	4,92	19,20 Kg	6	1,22	23,40 Kg	34	41,48	820 Kg	80 x 120 x 60
45 x 45 - GROUND	8,0 mm	4,92	17,21 Kg	7	1,42	24,45 Kg	34	48,28	856 Kg	80 x 120 x 60
31,4 x 61,2	9,0 mm	5,20	19,40 Kg	7	1,35	26,05 Kg	40	54,00	1073 Kg	80 x 120 x 77,8
30 x 60	8,0 mm	5,56	18,20 Kg	8	1,44	26,22 Kg	40	57,60	1074 Kg	80 x 120 x 75
33,3 x 50	9,0 mm	6,00	19,80 Kg	7	1,17	23,20 Kg	44	51,48	1045 Kg	80 x 120 x 81,6
36 x 36	9,0 mm	7,72	19,40 Kg	9	1,17	22,70 Kg	48	56,16	1115 Kg	80 x 120 x 87
15 x 75	9,0 mm	8,89	20,43 Kg	10	1,13	23,10 Kg	60	67,80	1411 Kg	80 x 120 x 90
33,3 x 33,3	9,0 mm	9,00	19,60 Kg	9	1,00	19,60 Kg	58	58,00	1160 Kg	80 x 120 x 81,6
33,3 x 33,3	7,8 mm	9,00	17,00 Kg	9	1,00	17,00 Kg	68	68,00	1180 Kg	80 x 120 x 81,6
30,0 x 33,3	9,0 mm	10,00	19,50 Kg	10	1,00	19,50 Kg	50	50,00	1000 Kg	80 x 120 x 75
16,5 x 33,3	9,0 mm	18,00	19,20 Kg	18	1,00	19,20 Kg	56	56,00	1100 Kg	80 x 120 x 81
16,5 x 16,5	9,0 mm	36,00	20,10 Kg	30	0,82	16,50 Kg	72	59,04	1215 Kg	80 x 120 x 81

RODAPÉ VIDRADO

Glazed Porcelain Skirting | Plinthe Grès Cérame Émaillé | Feinsteinzeug Glasiert Sockel | Плинтус Керамогранитный Глазурованный

FORMATO SIZE FORMAT FORMAT РАЗМЕР	ESPESSURA THICKNESS ÉPAISSEUR DICKE ПРОДУКТ	PEÇAS/M ² PCS/M ² PCS/M ² STK/M ² ШТ/М ²	PESO/M ² WEIGHT/M ² POIDS/M ² GEWICHT/M ² ВЕС/М ²	PZ X 	M ² X 	KG X 	 X 	M ² X 	KG X 	 C A X B X C CM
10 x 60	9,8 mm	—	—	15	—	16,50 Kg	48	—	792 Kg	80 x 120 x 75
7 x 75	9,0 mm	—	—	14	—	16,17 Kg	48	—	773 Kg	80 x 120 x 76
8 x 60	9,0 mm	—	—	16	—	14,88 Kg	56	—	833 Kg	80 x 120 x 72
8 x 59,2	10,0 mm	—	—	16	—	14,40 Kg	56	—	806 Kg	80 x 120 x 72
8 x 50	9,1 mm	—	—	20	—	15,24 Kg	63	—	960 Kg	80 x 120 x 87,8
8 x 45	9,1 mm	—	—	28	—	19,60 Kg	48	—	940 Kg	80 x 120 x 81
8 x 45	9,0 mm	—	—	28	—	17,39 Kg	49	—	852 Kg	80 x 120 x 72
8 x 33,3	7,8 mm	—	—	21	—	10,00 Kg	108	—	1080 Kg	80 x 120 x 81



REVESTIMENTO MONOPOROSA RETIFICADO

White Body Wall Tiles Rectified | Faiences Monocuisson Rectifieés | Steingut Weisscherbe Wandfliesen Rektifiziert | Облицовочная Плитка Однократного Обжига Ректифицированная

FORMATO SIZE FORMAT FORMAT РАЗМЕР	ESPESSURA THICKNESS ÉPAISSEUR DICKE ПРОДУКТ	PEÇAS/M ² PCS/M ² PCS/M ² STK/M ² ШТ/М ²	PESO/M ² WEIGHT/M ² POIDS/M ² GEWICHT/M ² ВЕС/М ²	PZ X	M ² X	KG X	X	M ² X	KG X	C A X B X C CM
35 x 100 - ENIGMA	12 -13,4 mm	2,86	20,60 kg	3	1,05	21,63 kg	24	25,20	544 kg	105 x 120 x 50
35 x 100 - LINE UP	12 -13,3 mm	2,86	20,90 kg	3	1,05	21,95 kg	24	25,20	552 kg	105 x 120 x 50
35 x 100 - SHAPE	12 -13,3 mm	2,86	20,44 kg	3	1,05	21,46 kg	24	25,20	552 kg	105 x 120 x 50
35 x 100	12 mm	2,86	20,90 kg	3	1,05	21,95 kg	26	27,30	595 kg	105 x 120 x 50
35 x 100 - PYRAMID	12,0-13,5 mm	2,86	20,60 kg	3	1,05	21,63 kg	24	25,20	544 kg	105 x 120 x 50
35 x 100 - FLOW	10,6 -12 mm	2,86	19,62 kg	3	1,05	20,60 kg	26	27,30	560 kg	105 x 120 x 50
35 x 100	10,5 mm	2,86	17,83 Kg	3	1,05	18,72 Kg	26	27,30	512 Kg	105 x 120 x 50
35 x 70	10,8 mm	4,08	18,47 kg	4	0,98	18,10 kg	56	54,88	1037 kg	105 x 120 x 85
30 x 60 - MYSTERY	10-11 mm	5,56	17,00 kg	6	1,08	18,33 kg	40	43,20	758 kg	80 x 120 x 75
30 x 60	10 mm	5,56	16,32 kg	6	1,08	17,63 kg	40	43,20	730 kg	80 x 120 x 75
22 x 75	11,5 mm	6,06	20,12 Kg	5	0,83	16,60 Kg	60	49,80	1020 Kg	105 x 120 x 81

GRÉS VIDRADO RETIFICADO

Porcelain Glazed Tiles Rectified | Grès Cérame Émaillé Rectifié | Feinsteinzeug Glasiert Rektifiziert | Керамогранит Глазурованный Ректифицированный

FORMATO SIZE FORMAT FORMAT РАЗМЕР	ESPESSURA THICKNESS ÉPAISSEUR DICKE ПРОДУКТ	PEÇAS/M ² PCS/M ² PCS/M ² STK/M ² ШТ/М ²	PESO/M ² WEIGHT/M ² POIDS/M ² GEWICHT/M ² ВЕС/М ²	PZ X	M ² X	KG X	X	M ² X	KG X	C A X B X C CM
59,2 x 59,2	10,0 mm	2,85	22,50 Kg	3	1,05	23,63 Kg	36	37,80	875 Kg	80 x 120 x 74,2
59,2 x 59,2	9,0 mm	2,85	19,96 Kg	3	1,05	20,60 Kg	36	37,80	767 Kg	80 x 120 x 74,2
50 x 50	9,0 mm	4,00	19,20 Kg	5	1,25	24,00 Kg	28	35,00	697 Kg	80 x 120 x 65
48,6 x 48,6	9,0 mm	4,23	19,80 Kg	5	1,18	23,40 Kg	28	33,04	678 Kg	80 x 120 x 63,6
44 x 44	9,0 mm	5,17	19,40 Kg	6	1,16	22,50 Kg	34	39,44	790 Kg	80 x 120 x 59
30 x 60	9,0 mm	5,56	19,40 Kg	7	1,26	24,40 Kg	40	50,40	1000 Kg	80 x 120 x 75
29,5 x 59,2	10,0 mm	5,73	22,50 Kg	6	1,05	23,63 Kg	36	37,80	875 Kg	80 x 120 x 74
35 x 35	9,0 mm	8,16	19,40 Kg	9	1,10	21,30 Kg	24	26,40	535 Kg	80 x 120 x 50
19,6 x 59,2	10,0 mm	8,62	22,50 Kg	9	1,05	23,63 Kg	36	37,80	875 Kg	80 x 120 x 88,8

EMBALAGEM

Package | Emballage | Verpackung | Упаковка

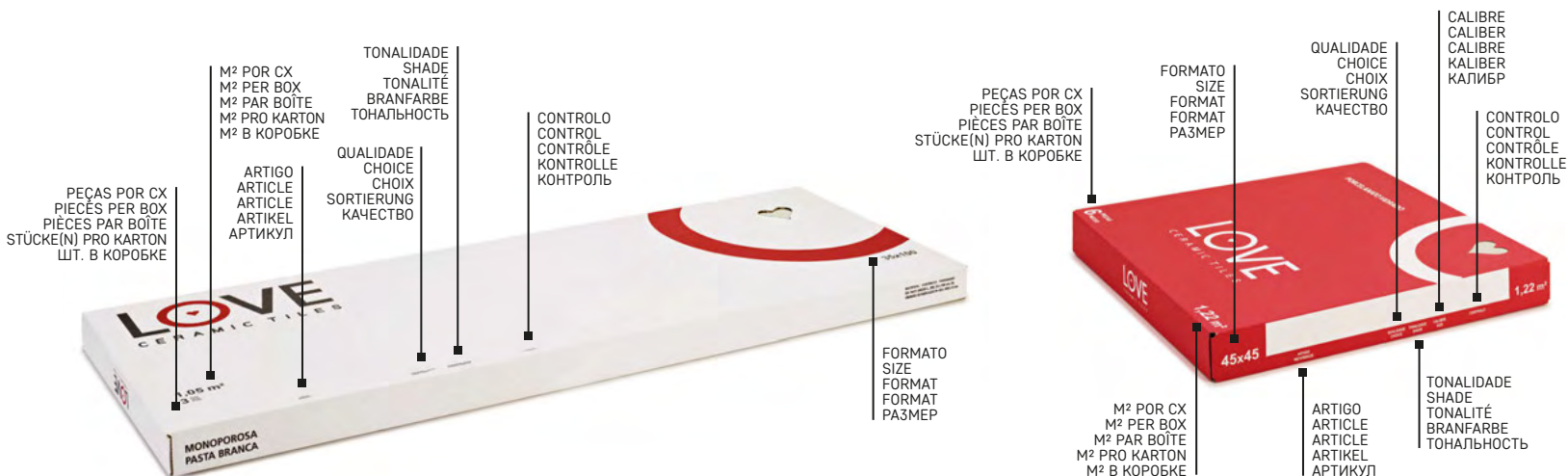

Technical Information Information Technique Technische Information Техническая Информация INFORMAÇÃO TÉCNICA

CERTIFICADOS

Certificates | Certificats | Zertifikaten | Сертификаты



Para mais informações contactar Love Tiles.
If necessary, for further queries, please contact Love Tiles.
Pour des renseignements complémentaires, prière de contacter Love Tiles.
Für weitere Erklärungen, kontaktieren Sie bitte Love Tiles.
Более детальную информацию Вы можете получить связавшись с Love Tiles.



HABITAR O PRESENTE VIVER O FUTURO

A Love Tiles cria coleções cerâmicas para habitar o presente e o futuro, plenas de beleza, dotadas de qualidade de um design exclusivo. A mesma beleza e a mesma harmonia que sonhamos para o mundo em nosso redor.
Para isso a Love Tiles cria e protege, reduzindo ao mínimo o impacto ambiental da sua atividade, por meio da constante pesquisa da eco sustentabilidade no local de trabalho, nas matérias utilizadas e nos processos produtivos, como demonstram as certificações ambientais obtidas. Queremos contribuir para que vivamos num mundo melhor, sabendo que a eco sustentabilidade é desenvolvimento olhando para o futuro...
Este é o nosso esforço quotidiano e a nossa responsabilidade social.

INHABIT THE PRESENT LIVE THE FUTURE

Love Tiles creates ceramic collections to live the present and the future, surrounded by beauty, protected by the quality of an exclusive design of living in total freedom. The same beauty and marvelous harmony that we dream for the world around us.
For this, Love Tiles creates and protects, by reducing to its minimum the environmental impact coming from its activity, through the constant research of the total eco-sustainability in the working environment, on the materials used and in the productive processes, as the obtained environmental certificates demonstrate. We want to contribute for a better world and only what is really eco-sustainable can be considered as development with future vision...
This is our daily commitment and our social responsibility.

HABITER LE PRÉSENT VIVRE L'AVENIR

Love Tiles crée des collections pour vivre le présent et l'avenir, entourées par la beauté, protégées de la qualité d'un design exclusif à vivre en toute liberté.
La même beauté et la même harmonie dont nous rêvons pour notre monde. C'est pour cette raison que Love Tiles crée et protège en réduisant au maximum l'impact environnemental de son activité, grâce à la permanente recherche de l'équilibre écologique dans l'environnement de travail, dans les matières utilisées et dans le processus productif, comme le démontre les certifications environnementales obtenues. Nous voulons contribuer à ce que vous viviez dans un monde plus beau, plus écologique donc plus développé et orienté vers l'avenir. Ceci est notre engagement quotidien et notre responsabilité sociale.

WOHNEN IN DER GEGENWART UND DIE ZUKUNFT ERLEBEN

Love Tiles kreiert Keramikkollektionen mit dem Konzept "wohnen in der gegenwart und die zukunft erleben". Diese Kollektionen zeichnet eine außergewöhnliche Schönheit, höchste Qualität und exklusives Design aus. Diesselbe Schönheit und Harmonie, die wir uns für die Welt in unserem Umkreis erträumen.
Danach richtet Love Tiles ihre Produktion aus: Für die Herstellung benutzen wir umweltschonende Verfahren, m.a.W. die Umwelt auswirkungen sind auf das Mindestmaß reduziert. Es gelingt uns durch konstante Forschungsarbeiten auf dem Gebiet der Öko-Nachhaltigkeit am Arbeitsplatz, bei den verwendeten Materialien und bei den Herstellungsverfahren. Davon zeugen die Umweltzertifikate, mit denen wir ausgezeichnet wurden. Wir möchten einen Beitrag für eine bessere Welt leisten, wohl wissend, dass die Öko-Nachhaltigkeit Entwicklung in die Zukunft bedeutet.
Dies ist unser alltägliches Anliegen und unsere soziale Verantwortung.

TECNOLOGIA DE VANGUARDA

Cada matéria prima natural utilizada, cada processo produtivo e cada tecnologia da complexa actividade da unidade industrial da Love Tiles, são estudadas de forma a minimizar o impacto ambiental, poupando e reciclando, com a vontade de transformar desperdícios em recursos e otimizar a utilização da energia produzida. A Love Tiles está na vanguarda na adoção de medidas ecologicamente sustentáveis as quais são demonstradas pelos mais minuciosos controlos quotidianamente efectuados.

CUTTING-EDGE TECHNOLOGY

Each raw material used, each productive process and each technology of the complex activity of the Love Tiles sites are studied in order to reduce the environmental impact, by saving, recycling, filtering, with the will of transforming the waste in resources and optimize the use of energy. Love Tiles is on the cutting-edge of adopting ecologically sustainable practices and this is demonstrated by the most accurate controls, repeated on a daily basis.

TECHNOLOGIE D'AVANT-GARDE

Chaque matière première, chaque processus productif et chaque technologie de la complexe activité des établissements de Panariagroup sont étudiés de façon à limiter l'impact environnemental en épargnant, recyclant et filtrant avec la volonté de transformer les déchets en ressources et optimiser l'usage de l'énergie produite. Gres Panaria Portugal est à l'avant-garde dans l'action et les pratiques pour l'environnement comme le démontrent les contrôles les plus exigeants répétés au quotidien.

SPITZENTECHNOLOGIE

Love Tiles hat die verwendeten Rohstoffe, Produktionsverfahren und Techniken in der komplexen Unternehmensaktivität im Bereich der industriellen Produktion des Unternehmens im Hinblick auf die Umweltauswirkungen eingehendst analysiert. Materialeinsparungen und Recycling stehen auf der Tagesordnung. Aus Abfällen werden Ressourcen. Die Nutzung freigesetzter Energie ist optimiert. Love Tiles ist führend, was die Verwendung von ökologisch nachhaltigen Maßnahmen betrifft. Tägliche minutiös durchgeführte Kontrollen sind der Beweis dafür.

	reutilização de caco cru recycling non fired material réutilisation du tesson Wiederverwendung unbearbeiteter Scherben
	reciclagem de caco cozido fired material, used for construction recyclage du tesson cuit Recycling von erhitzten Scherben
	water, every drop counts 100 % reciclagem de água do processo recyclage des eaux du processus productif 100 % - es Recycling von in Verfahren benutztes Wasser
	reducing emission baixas emissões gasosas para a atmosfera faibles émissions de gaz dans l'atmosphère geringe Abgabe gashaltiger Emissionen in die Atmosphäre
	energy saving poupança de energia économie d'énergie Energieeinsparung
	from packaging to recycling 100% de materiais recicláveis utilizados na embalagem 100% de matériaux recyclables utilisés dans l'emballage 100% Recycling-Material wird für Verpackungen benutzt
	sustentabilidade dos produtos cerâmicos sustainability of ceramic products durabilité des produits céramiques Nachhaltigkeit von Keramikprodukten
	FAO pallets paletes FAO FAO palletes FAO Palletten

A CERTIFICAÇÃO AMBIENTAL

A unidade industrial da Love Tiles obteve certificações ambientais internacionais de grande prestígio. Entidades e organismos de controlo reconheceram oficialmente o trabalho feito pela empresa para a salvaguarda dos recursos naturais do planeta. Esta certificação testemunha as boas práticas ambientais da Love Tiles, na salvaguarda do desenvolvimento sustentável. Esta é uma demonstração concreta de como é possível conciliar Qualidade, Inovação Industrial e Design com uma séria política de salvaguarda do ambiente.

THE ENVIRONMENT CERTIFICACION

Love Tiles have obtained the most prestigious International environmental certifications. Agencies and control bodies have officially recognized the work done by the company for the safeguarding of the earth's natural resources. These certifications are proof of the high standards attained by Love Tiles, a company which is a forerunner in terms of sustainable development. These are a clear proof of how it is possible to reconcile quality, industrial innovation and design with a serious policy for environmental safeguard.

LA CERTIFICATION ENVIRONNEMENTALE

Love Tiles a obtenu de prestigieuses certifications environnementales internationales. Les entités et les organismes de contrôle ont officiellement reconnu le travail fourni par l'entreprise pour la préservation des ressources naturelles de la planète. Cette certification témoigne des bonnes pratiques environnementales de Gres Panaria Portugal, pour la protection du développement durable. C'est une démonstration concrète de l'engagement de l'entreprise en termes de Qualité, d'Innovation et de Design, le tout allié à une sérieuse politique de protection de l'environnement.

UMWELTZERTIFIZIERUNG

ie Produktionseinheit der Love Tiles wurde weltweit mit Umweltertifizierungen von großem Prestige ausgezeichnet. Körperschaften und Kontrolleinrichtungen erkannten offiziell das Unternehmen für seine Arbeit zum Erhalt der Naturressourcen auf der Erde an. Die Zertifizierungen bezeugen die guten Umweltpraktiken der Love Tiles für die Wahrung der nachhaltigen Entwicklung. Dies ist ein konkreter Beweis dafür, dass es möglich ist, Qualität, industrielle Innovation und Design mit einer ernsthaften Politik der Umwelterhaltung zu vereinbaren.

	ISO 14001 para estabelecimentos de baixo impacto ambiental e alta eficiência. for production sites with low impact and high efficiency. produit fabriqué sans négliger l'environnement Produkt herstellung unter Einbeziehung der Umwelt
	EMAS para ser verde e transparente being green and transparent pour être vert et transparent grün und transparent
	LEED + GREEN BUILDING COUNCIL ITALY + CASA CLIMA contributo para a sustentabilidade da construção. Os produtos Love Tiles contribuem para uma construção sustentável, por serem um produto saudável, durável e de baixa manutenção. Contribution towards sustainable construction through its health friendly, long lasting and low maintenance products. contribution à la durabilité de la construction. Les produits Love Tiles contribuent à une construction durable car il s'agit d'un produit sain, durable et dont les exigences en matière d'entretien son faibles Ein Beitrag für die Nachhaltigkeit im Bausektor. Die Produkte der Love Tiles leisten einen Beitrag für einen nachhaltigen Bau, denn es handelt sich um gesunde, haltbare Produkte mit niedrigem Wartungsaufwand.



Technical Information
Information Technique
Technische Information
Техническая Информация
INFORMAÇÃO TÉCNICA



GENERAL SALES CONDITIONS

1 – Application of the condition.

1.1. The following general conditions (hereinafter “the CONDITIONS” constitute an integral part of the sales contract of tiles and other ceramic products (hereinafter “the PRODUCT OF PRODUCTS”) manufactured by Love Tiles - Grés Panaria Portugal, S.A. (hereinafter “the MANUFACTURER”).

Except for specific cases, where these conditions are expressly derogated by written agreements signed by the MANUFACTURER, they represent the only terms for these sales. If one or more parts of these CONDITIONS, or single contracts included therein, are found to be invalid, the CONDITIONS, or details thereof, will remain valid as a whole; the invalid terms will be replaced with new agreements, which will reproduce, as far as it is possible, the original intention of the parties.

2 – Execution of the sales contract - Delivery of products

2.1. The contract is executed when the proposing party or the purchaser is aware of the written consent of the other party.

2.2. An order that has not been confirmed in writing cannot, under circumstances be considered as accepted, unless performed by the MANUFACTURER by way of the shipment or delivery of the PRODUCTS. The partial delivery of ordered PRODUCTS does not imply the acceptance of the entire order, but only that part of the PRODUCTS which has been effectively delivered.

2.3. Unless otherwise agreed in writing, the delivery of the PRODUCTS in Portugal or abroad, will be carried out according to the “Ex-works” term. This term of delivery, as well as the other terms of the delivery which may be agreed upon in writing, is referred to the ICC INCOTERMS in force at the moment of the sale.

2.4. Unless otherwise agreed, all the dates which are indicated for delivery shall be considered as approximate.

3 – Product Specifications Warranty - Claims

3.1. The PRODUCTS manufactured by Love Tiles - Grés Panaria Portugal, S.A. are produced according to the European UNI – DIN – EN rules. The MANUFACTURER sells exclusively to professional dealers; these are responsible for giving the right technical information to the final user or retailers.

The PRODUCTS classifications are indicated by the MANUFACTURER on advertising material and/or in the price lists. Therefore the purchaser must use the PRODUCTS according to the specifications of the MANUFACTURER. In order to ease the suggestions of use and conform the standard classifications to the specific production of the MANUFACTURER, on every product, price-list or catalogue there are specific symbols that indicate the intended use suggested by the MANUFACTURER.

3.2. The shade differences are not a defect of the PRODUCT, but a specific characteristic of the material which has been fired at a high temperature. The special “freeze-proof” requirement does not only apply to PRODUCTS that the MANUFACTURER has specifically guaranteed by giving specific indication on the advertising material and/or price lists. Without this specific indication the PRODUCTS shall be considered to be only and exclusively for internal use, or, in any case, to be used in places not exposed to the elements. The “freeze-proof” warranty has not a two years term.

3.3. The tiles with polished surfaces should not be used on ground floor rooms that have external access, not in rooms where there is a particular heavy walking. The shiny tiles may also be slippery, especially when wet; for this reason the MANUFACTURER, recommend not to use These PRODUCTS in public places. For places intended to heavy walking, the purchaser shall only buy PRODUCTS classified by the MANUFACTURER as PEI V, and in particular those PRODUCTS that the MANUFACTURER specifically recommends for use in public places.

3.4. The representations of PRODUCTS on depliants and other advertising material of the MANUFACTURER, are solely illustrative and do not represent necessarily the final aesthetic result of the laying of that specific PRODUCT.

3.5. The MANUFACTURER guarantees the good quality and the absence of defects of the PRODUCTS supplied. The warranty does not apply to PRODUCTS classified by the MANUFACTURER as inferior to the 1st choice quality, or to stocks of PRODUCTS which are gone out of production, when sold in bulk or indicated as special lot.

3.6. The MANUFACTURER shall not be liable for any defects and/or anomalies in the PRODUCTS due not to the quality of the PRODUCTS, but to the improper use of the PRODUCTS by the purchasers and/or third parties acting on their behalf. In particular, the MANUFACTURER shall not accept any claim or disputes in connection with the situations above described.

3.7. The claims must be notified in writing to the MANUFACTURER by the purchaser within (60) days from the date of delivery of the goods. In case of hidden defects the notice period will be (60) days from the date of the discovery of the defect. Under no circumstances the MANUFACTURER shall be liable for defects which are discovered twelve months after the delivery of the PRODUCTS to

the first Purchaser of the MANUFACTURER and therefore the Purchaser’s appeal action against the MANUFACTURER is exclusively limited within 2 years from delivery of the goods.

3.8. In principle, the warranty does not apply to defect discovered on PRODUCTS not yet laid down. For hidden defects discovered after the PRODUCTS had been laid down, the warranty may apply only if the MANUFACTURER has verified that the laying of the PRODUCT has been done according to the best knowledge of workmanship (DIN 18352).

3.9. The warranty given by the MANUFACTURER is limited to the replacement of defective products with other non-defective of the same type, plus the transportation costs. It is expressly excluded the reimbursement of any other costs and/or expenses and in particular the costs of demolition and relaying. In all circumstances, the warranty of the MANUFACTURER cannot exceed five times the value of the claimed material, up to a maximum of Euro 10,000,00.

3.10. The MANUFACTURER shall not be liable for claims due to a classification of ceramic materials made by organisms of certification and control different from the European ones indicated in art. 3.1., on the basis of technical specifications which do not correspond with those indicated by the MANUFACTURER. Any eventual technical expertise request by the purchaser shall be based on the correspondence of the materials sold with the technical specifications indicated by the MANUFACTURER, at that time in force in Portugal.

4 – Prices and Payment Conditions

4.1. The selling prices of the PRODUCTS are those indicated in the MANUFACTURER’S price list in force at the date of the order’s confirmation. For the PRODUCTS which are intended for foreign markets the price shall be calculated, at the MANUFACTURER choice, in the foreign currency of the country of destination or in Euro.

4.2. Unless otherwise agreed, payments shall be made by the purchaser through bank transfer, within 30 days from the date of the invoice. All the bank and negotiation expenses are at purchaser’s charge. In case of delay in payment, the MANUFACTURER, along with any other damages, shall be entitled, without any prior notice to the purchaser, to an overdue interest equal to the EURIBOR, 6 (six) months, rate plus a percentage of 5%.

5 – Manufacture’s Agents

5.1. The agents of the MANUFACTURER promote the sales of the products and are not authorized to act in the name and on behalf of the MANUFACTURER, unless specific written authorization.

5.2. The orders collected by the agents are not binding for the MANUFACTURER, and shall therefore be expressly accepted in writing by the MANUFACTURER itself.

6 – Retention of Title

6.1. It is agreed between the parties that the sale of PRODUCTS is made under the retentions of title right of the MANUFACTURER until the complete payment of the agreed price has been made by the purchaser. However, the risk of the loss of the goods in transferred to the purchaser at the moment of the delivery of the PRODUCTS. In case of sales into foreign countries, when the goods are sold and delivered to third parties within the Purchaser’s normal commercial activities and the property of the goods has not been yet transferred, the retention of title right of the MANUFACTURER still remains valid also against third parties, if permitted by the law.

6.2. In case of delay in payments the MANUFACTURER is entitled, without any formality, including any prior notice to the purchaser, to collect all the goods subject to the retention of title and, if permitted by the law, all the relating documents of credit toward third parties, being expressly reserved the right of the Manufacturer to proceed at law for the compensations of the damages suffered.

7 – Force Majeure

7.1. The MANUFACTURER shall not be liable to the purchaser for any unfulfilment of the contract, including the non-delivery or delayed delivery, caused by events that are out of the MANUFACTURER’S reasonable control, such as, for example the non-delivery or delayed of working materials by the suppliers, factory breakdowns, strikes or other trade union actions, interruption of energy supplies, suspension or difficulties with transports.

8 – Applicable Law – Competent Court

8.1. The export sales contracts in which the MANUFACTURER takes part are governed, where not derogated by the present CONDITIONS, by the Vienna Convention of April 11th 1980 on the International Sales Contracts.

8.2. For any disputes relating to the sale of PRODUCTS of the MANUFACTURER and all other related issues, the only competent Court shall be the place where the MANUFACTURER has its registered seat, also for what concerns the enforcement of documents of credit received by the MANUFACTURER as a mean of payment.

CONDITIONS GÉNÉRALES DE VENTE

1 – Applicabilité des Conditions

1.1. Les conditions générales de vente énoncées et spécifiées par la suite – dorénavant désignées "CONDITIONS" -, font partie intégrante du contrat de vente de mosaïques et d'autres produits céramiques - dorénavant désignés "PRODUIT" ou "PRODUITS" - fabriqués par Love Tiles - Gres Panaria Portugal, S.A., également désigné "FABRICANT".

1.2. Sauf cas spécifiques ou exceptionnels, où l'application de ces conditions est expressément modifiée par accord écrit et signé par le FABRICANT, elles représentent les conditions exclusives appliquées à cette vente. Si une ou plusieurs des parties des présentes CONDITIONS ou contrats, individuellement considérées et dont elles font parties, sont jugées nulles, invalides ou inapplicables pour des raisons de force majeure, les CONDITIONS générales ou particulières seront dans leur ensemble valides, et les conditions invalides seront remplacées par de nouvelles dispositions qui reproduiront, aussi bien que possible, l'intention originale des parties.

2 – Exécution du Contrat de Vente – Livraison des Produits

2.1. Le contrat est célébré lorsque le contractant ou acheteur prend connaissance de l'acceptation écrite du contrat par l'autre partie.

2.2. Une commande non confirmée par écrit ne peut, en aucune circonstance, être considérée comme acceptée, excepté si elle est exécutée par le FABRICANT à travers l'envoi ou la livraison des PRODUITS. La livraison partielle des PRODUITS commandés n'implique pas l'acceptation de la totalité de la commande, mais uniquement de la partie des PRODUITS effectivement livrés.

2.3. Sauf cas expressément accordé par écrit, la livraison des PRODUITS se fera exclusivement sur le territoire métropolitain du Portugal (Portugal Continental).

2.4. Sauf accord contraire, toutes les dates indiquées pour des effets de livraison, seront considérées comme des dates approximatives.

3 - Caractéristiques des Produits - Garantie - Réclamations

3.1. Les PRODUITS fabriqués par Love Tiles - Gres Panaria Portugal, S.A. sont produits conformément aux normes européennes applicables. Le FABRICANT vend exclusivement à des revendeurs professionnels, ceux-ci devant fournir les informations techniques correctes aux utilisateurs finaux ou aux détaillants.

Le classement des PRODUITS est indiqué par le FABRICANT sur le matériel publicitaire et/ou sur les listes de prix. En conséquence, l'acheteur devra utiliser les PRODUITS conformément aux spécifications du FABRICANT.

Afin de faciliter la suggestion d'usage et d'adapter la spécification standard à la production spécifique du FABRICANT, il existe, sur tous les produits, les listes de prix ou les catalogues, des symboles spécifiques qui indiquent l'utilisation conseillée par le FABRICANT pour chaque produit.

3.2. Les différences de tonalité ou la chrominance éventuellement constatées ne sont pas des défauts du PRODUIT, mais une caractéristique spécifique du matériau céramique soumis à une cuisson à hautes températures. La caractéristique particulière de "résistance à la congélation" ne s'applique qu'aux produits que le FABRICANT aura spécifiquement garantis à cet effet avec indication expresse sur son matériel publicitaire et/ou sur les listes de prix. En l'absence de cette indication, les produits se destinent uniquement et exclusivement à un usage intérieur ou, en tous cas, à une utilisation en local non exposé à des éléments atmosphériques susceptibles de modifier les caractéristiques de résistance ou d'apparence originale du PRODUIT (ex. : précipitation atmosphérique, soleil, humidité, basses températures, etc.).

3.3. Les mosaïques de finition polie peuvent changer d'aspect quand ils sont utilisés au sol dans des pièces ayant accès à l'extérieur, ou dans des pièces avec une intense circulation piétonne. Les mosaïques polies peuvent aussi être glissantes, particulièrement quand elles sont mouillées ou sous l'effet de l'humidité. Conscient de cette particularité, le FABRICANT ne recommande pas l'utilisation de ces PRODUITS dans des lieux publics. Pour les locaux dont le passage ou la circulation de personnes est intense, l'acheteur devra acquérir des PRODUITS classés par le FABRICANT "PEI V" ou "Grès Porcelanique Pleine Masse", notamment les PRODUITS que le FABRICANT recommandera tout particulièrement pour une utilisation dans des lieux publics.

3.4. Les présentations des PRODUITS sur brochures ou sur un tout autre matériel promotionnel du FABRICANT sont purement illustratives et ne représentent pas nécessairement le résultat final esthétique découlant de l'installation de ce produit spécifique.

3.5. Le FABRICANT garantit la bonne qualité et l'absence de défauts sur les PRODUITS fournis. La garantie ne s'applique pas aux PRODUITS classés par le FABRICANT comme étant de qualité inférieure à la qualité de 1er choix, ou aux stocks de produits discontinus, lorsque ceux-ci sont vendus en gros ou sous l'indication lot spécial.

3.6. Le FABRICANT n'est pas responsable des défauts et/ou anomalies existant sur les PRODUITS qui ne dérivent pas des spécifications techniques de ceux-ci, mais qui sont la conséquence d'une utilisation inadéquate des PRODUITS de la part des acquéreurs et/ou de tierces personnes qui agissent en son nom. Notamment, le FABRICANT n'accepte aucune réclamation ou litige lié aux situations précédemment décrites.

3.7. Les réclamations découlant de l'existence de défauts visibles ou cachés devront être adressées par écrit au FABRICANT par l'acheteur dans un délai de 60 jours à compter de la date de livraison des marchandises. La responsabilité du fabricant pour des défauts inhérents aux produits livrés à l'acheteur est expressément limitée à un délai de 2 ans à compter de la date de réception du bien par l'acheteur.

3.8. En général, la garantie ne s'applique qu'aux défauts détectés sur des produits qui n'ont pas encore été remis. Relativement aux défauts détectés après que les PRODUITS aient été remis, la garantie ne peut s'appliquer que si le FABRICANT confirme que la remise du PRODUIT a été réalisée conformément aux meilleures règles d'activité (DIN 18352), et en application des procédures décrites dans le manuel d'application et d'entretien du FABRICANT.

3.9. La garantie accordée par le FABRICANT se limite à l'échange des produits défectueux par d'autres produits du même type sans défaut, en plus des frais de transport. Le remboursement de tout autre frais et/ou dépenses est expressément exclu, notamment les frais de destruction et de remise en place. Quoiqu'il en soit, la garantie du FABRICANT ne peut dépasser cinq fois la valeur du matériel faisant l'objet de la réclamation, jusqu'à une valeur maximum de 10.000 Euros.

3.10. Le FABRICANT n'est pas responsable des réclamations dues à un classement de matériaux céramiques réalisé par des organismes de certification et de contrôle autres que les organismes européens mentionnés à l'article 3.1, reposant sur des spécifications techniques qui ne correspondent pas aux spécifications indiquées par le FABRICANT. Toute éventuelle analyse technique spécialisée sollicitée par l'acheteur se basera sur la correspondance du matériel vendu aux caractéristiques techniques indiquées par le FABRICANT, actuellement en vigueur au Portugal.

4 – Prix et Conditions de Paiement

4.1 Les prix de vente des PRODUITS sont ceux indiqués sur la liste de prix pratiquée par le FABRICANT à la date de confirmation de la commande. Pour les contrats de vente avec livraisons séparées, le prix sera celui mentionné sur la liste de prix en vigueur à la date de chacune des commandes, sauf si les parties disposent par écrit d'un accord contraire.

Pour les PRODUITS destinés aux marchés étrangers, le prix sera calculé, sur indication du FABRICANT, dans la devise étrangère du pays de destination ou en Euros.

4.2. Sauf si accord contraire, les paiements s'effectueront par virement bancaire, dans un délai de 30 jours à compter de la date de la facture. Tous les frais bancaires et de virement sont à la charge de l'acheteur. En cas de retard de paiement, le FABRICANT, en plus de tout autre dommage, se réserve le droit, sans avis préalable à l'acheteur, d'appliquer un taux d'intérêts moratoires et punissables équivalent au taux EURIBOR à 6 mois majoré de 5%.

5 - Agents du Fabricant

5.1. Les agents du FABRICANT promeuvent la vente des PRODUITS et ne sont pas autorisés à agir au nom et pour le compte du FABRICANT, excepté en cas d'autorisation spécifique expresse à cet effet.

5.2. Les commandes reçues par les agents n'engagent pas le FABRICANT et devront, par conséquent, être expressément acceptées par écrit par le FABRICANT lui-même.

6 – Réserve de Propriété

6.1. Les parties s'accordent à ce que la vente des PRODUITS soit conclue avec réserve de propriété du FABRICANT jusqu'à ce que le règlement complet du prix accordé soit intégralement soldé par l'acheteur. Cependant, le risque de perte de marchandises est transféré à l'acheteur au moment de la livraison des PRODUITS.

6.2. En cas de ventes à des pays étrangers, lorsque les marchandises sont vendues et livrées à des tiers dans le cadre des activités commerciales normales de l'acheteur et que la propriété des marchandises n'a pas encore été transférée, le FABRICANT conserve son droit de propriété vis-à-vis des tiers.

6.3. En cas de retard de paiement, le FABRICANT se réserve le droit, sans recourir à aucune formalité, y compris l'avis préalable à l'acheteur, d'exiger la remise de toutes les marchandises soumise à la réserve de propriété et, si légalement accordé, de tous les titres de crédits devant des tiers, et conserve expressément le droit de recourir à tous les moyens légaux à sa disposition au vue de la réparation des dommages subis ou à subir en conséquence du comportement défaillant de l'acheteur.

7 – Force Majeure

7.1. Le FABRICANT n'est pas responsable devant l'acheteur du non-respect du contrat, y compris de la non-livraison et de la livraison en retard du PRODUIT, provoquée par des événements indépendants de son contrôle, comme par exemple, la non-livraison ou la livraison en retard de matériaux de la part de fournisseurs, les pénuries dans les installations, les grèves, les faits naturels, les coupures d'énergie électrique, les pénuries ou les difficultés de transport.

8 – Législation Applicable – Tribunal Compétent

8.1. Les contrats d'exportation de marchandises célébrés par le FABRICANT sont régis, dans les cas où ils ne sont pas abrogés par les présentes CONDITIONS, par la Convention de Vienne du 11 avril 1980 sur les contrats de vente internationale de marchandises.

8.2. Tout litige relatif à la vente de PRODUITS du FABRICANT et de tout autre matériau, se fera uniquement auprès du Tribunal compétent, avec renoncement de tout autre tribunal, dans le ressort duquel le FABRICANT a son siège social. Cette règle de tribunal compétent s'applique également à l'exécution des titres de crédit reçus par le FABRICANT comme moyen de paiement.

Technical Information
Information Technique
Technische Information
Техническая Информация
INFORMAÇÃO TÉCNICA

ALLGEMEINE VERKAUFSBEDINGUNGEN

1 - Anwendbarkeit der Geschäftsbedingungen

1.1. Die im Anschluss angeführten und beschriebenen Geschäftsbedingungen - nachstehend "GESCHÄFTSBEDINGUNGEN" genannt - sind Bestandteil des Kaufvertrags für Fliesen und andere Keramikprodukte - nachstehend "WARE" oder "WAREN" genannt - die von Love Tiles - Gres Panaria Portugal, S.A. - nachstehend auch "HERSTELLER" genannt - hergestellt werden.

1.2. Abgesehen von Sonder- oder Ausnahmefällen, in denen die Anwendung dieser Geschäftsbedingungen durch eine vom HERSTELLER unterschriebene schriftliche Vereinbarung ausdrücklich geändert wird, stellen sie die einzigen auf den Verkauf anwendbaren Geschäftsbedingungen dar. Sollten sich einzelne Bestandteile der vorliegenden GESCHÄFTSBEDINGUNGEN oder Verträge auf irgendeine Weise als nichtig, unwirksam oder infolge höherer Gewalt undurchführbar erweisen, bleibt davon die Wirksamkeit der Allgemeinen oder Besonderen GESCHÄFTSBEDINGUNGEN im Übrigen unberührt. An die Stelle der unwirksamen Bestimmungen treten sodann dieser Bestimmung möglichst nahekommende wirksame Regelungen.

2 - Vertragserfüllung - Warenlieferung

2.1. Der Vertrag gilt dann als abgeschlossen, wenn die vorschlagende Vertragspartei oder der Käufer die schriftliche Annahme desselben durch die Gegenpartei zur Kenntnis nimmt.

2.2. Eine schriftlich nicht bestätigte Bestellung kann unter keinen Umständen als nicht angenommen gelten, es sei denn, dass sie anhand des Versands oder der Lieferung der WARE vom HERSTELLER erfüllt wurde. Die Teillieferung der bestellten WARE setzt nicht die Annahme der gesamten Bestellung voraus, sondern lediglich des Teils der WARE, der tatsächlich ausgeliefert wurde.

2.3. Mangels ausdrücklicher abweichender schriftlicher Vereinbarung erfolgt die Lieferung der WAREN ausschließlich auf portugiesischem Festland.

2.4. Mangels abweichender Vereinbarung verstehen sich alle für Lieferzwecke angegebenen Termine als ungefähre Termine.

3 - Wareneigenschaften - Garantie - Beschwerden

3.1. Die von Love Tiles - Gres Panaria Portugal, S.A. hergestellten WAREN stehen im Einklang mit der geltenden europäischen Gesetzgebung. Der HERSTELLER verkauft ausschließlich an professionelle Wiederverkäufer, die für die Weitergabe von korrekter Information an Endverbraucher oder Einzelhändler zuständig sind.

Die Klassifizierung der WAREN wird vom HERSTELLER in Werbematerial bzw. Preislisten angeführt. Der Käufer hat die WAREN somit in Übereinstimmung mit den Vorgaben des HERSTELLERS einzusetzen.

Zur Vereinfachung der empfohlenen Anwendung und Anpassung der Standardspezifikation an die spezifische Produktion des HERSTELLERS, weisen alle Waren, Preislisten und Broschüren besondere Symbole auf, welche die vom HERSTELLER bevorzugte Benutzung einer jeden Ware anzeigen.

3.2. Eventuell festgestellte Farb- oder Chrominanzunterschiede sind nicht einem Fehler der WARE zuzuschreiben, sondern stellen besondere Merkmale von keramischem Material dar, das bei hohen Temperaturen gebrannt wird. Die besondere gefrierbeständige Eigenschaft gilt nur für die Erzeugnisse, die vom HERSTELLER in seinem Werbematerial bzw. Preislisten ausdrücklich als solche gekennzeichnet sind. Fehlt diese Kennzeichnung, sind die Erzeugnisse einzig und allein für eine innere Anwendung bzw. grundsätzlich eine Anwendung in Räumen vorgesehen, die keinen atmosphärischen Elementen ausgesetzt sind, welche die Widerstandseigenschaften oder die ursprüngliche Erscheinung der WARE ändern könnten (z. Bsp. Niederschlag, Sonne, Feuchtigkeit, niedrige Temperaturen, usw.)

3.3. Das Aussehen von polierten Fliesen kann Änderungen erfahren, wenn diese in Räumen benutzt werden, die von außen zugewandert werden oder Räumen, in denen mit viel Personenverkehr zu rechnen ist. Polierte Fliesen können ebenfalls rutschig sein, besonders wenn sie nass oder unter Einwirkung von Feuchtigkeit sind. Aus diesem Grund rät der HERSTELLER von einer Anwendung dieser WAREN in öffentlichen Bereichen ab. Für Bereiche mit starkem Personenverkehr ist der Käufer lediglich gehalten WAREN einzusetzen, die vom HERSTELLER als «PEI V» oder «Feinsteinzeug in voller Masse» eingestuft werden, bzw. insbesondere die WAREN, die vom HERSTELLER ausdrücklich für die Anwendung in öffentlichen Bereichen empfohlen werden.

3.4. Die Darstellungen von WAREN in Broschüren oder sonstigem Werbematerial des HERSTELLERS dienen nur der Veranschaulichung und stellen das ästhetische Endergebnis der Verlegung dieses spezifischen Produkts nicht verbindlich dar.

3.5. Der HERSTELLER gewährleistet die Qualität und Mängelfreiheit der gelieferten WAREN. Die Gewährleistung findet keine Anwendung auf WAREN, die vom HERSTELLER nicht als erste Qualität eingestuft sind sowie Warenbestände, die nicht mehr hergestellt werden, wenn sie als Schüttgut verkauft oder als Sondercharge ausgezeichnet sind.

3.6. Der HERSTELLER haftet nicht für Mängel oder Fehlfunktionen der WARE, die nicht von den jeweiligen technischen Spezifikationen hervorgehen, sondern von einer unsachgemäßen Verwendung der WARE seitens der Käufer bzw. von Dritten in ihrem Namen. Insbesondere akzeptiert der HERSTELLER keine mit den oben erwähnten Situationen in Verbindung stehende Beschwerden oder Streitigkeiten.

3.7. Kunden haben dem HERSTELLER gegenüber erkennbare oder versteckte Mängel innerhalb von 60 Tagen nach Erhalt der Ware schriftlich geltend zu machen. Die Haftung des Herstellers für eine fehlerhafte Ware, die dem Käufer ausgeliefert wurde, beschränkt sich ausdrücklich auf 2 Jahre ab Lieferungstermin an den Käufer.

3.8. Im Allgemeinen umfasst die Garantie ausschließlich festgestellte Mängel in Waren, die noch nicht eingesetzt wurden. Nach Einsatz der WAREN festgestellte Mängel werden nur dann von der Garantie erfasst, wenn der HERSTELLER bestätigt, dass die betreffende Verlegung in Übereinstimmung mit der bewährten guten Praxis (DIN 18352), wie auch gemäß den in der Betriebs- und Wartungsanleitung des HERSTELLERS beschriebenen Verfahren erfolgte.

3.9. Die Garantie des HERSTELLERS ist auf den Austausch der fehlerhaften Ware für fehlerfreie Ware desselben Typs, zuzüglich Transportkosten, beschränkt. Die Rückzahlung irgendwelcher anderen Kosten und Ausgaben, insbesondere Rückbau- und Wiederverlegungskosten, sind ausdrücklich ausgeschlossen. Unter keinen Umständen kann die Garantie des HERSTELLERS das Fünffache des beanstandeten Materials überschreiten, bis zu einem Höchstwert von 10.000 Euro.

3.10. Der HERSTELLER haftet nicht für Beschwerden, die auf eine Klassifizierung von keramischem Material zurückzuführen sind, die nicht von den in Art. 3.1 angeführten europäischen Zertifizierungs- und Prüfstellen durchgeführt wurden, und auf technische Spezifikationen begründen, die nicht mit denen des HERSTELLERS übereinstimmen. Eine vom Käufer eventuell beantragte technische Begutachtung wird auf die Abstimmung des verkauften Materials mit den in Portugal zu dem Zeitpunkt geltenden und vom HERSTELLER angeführten technischen Merkmalen beruhen.

4 - Preise und Zahlungsbedingungen

4.1 Die Verkaufspreise der WAREN sind den bei der Auftragsbestätigung geltenden Preislisten des HERSTELLERS zu entnehmen. Mangels ausdrücklicher abweichender schriftlicher Vereinbarung der Vertragsparteien gilt für Verkaufsverträge mit Teillieferungen der zum Zeitpunkt jeder Lieferung gültige Preis.

Bei WAREN, die für ausländische Märkte bestimmt sind, wird der Preis, je nach Anweisung des HERSTELLERS, entweder in der Fremdwährung des Bestimmungslands oder in Euro berechnet.

4.2. Mangels ausdrücklicher abweichender Vereinbarung erfolgen Zahlungen innerhalb von 30 Tagen ab Rechnungsdatum durch Banküberweisung. Alle Bank- und Überweisungsgebühren trägt der Käufer. Bei Zahlungsverzug ist der HERSTELLER ohne vorherige Mitteilung an den Käufer berechtigt, auch bezüglich etwaiger anderer Schäden, Verzugszinsen in Höhe von 5% über dem EURIBOR zu verlangen.

5 - Vertreter des Herstellers

5.1. Die Vertreter des HERSTELLERS fördern den Verkauf der WAREN und sind nicht ermächtigt, im Namen und auf Rechnung des HERSTELLERS zu handeln, abgesehen von den Fällen, in denen ihnen dafür eine ausdrückliche Erlaubnis erteilt wird.

5.2. Die von den Vertretern entgegengenommenen Bestellungen binden den HERSTELLER nicht und müssen deshalb schriftlich vom HERSTELLER selbst angenommen werden.

6 - Eigentumsvorbehalt

6.1. Für den Verkauf der WAREN vereinbaren die Vertragsparteien einen Eigentumsvorbehalt zugunsten des HERSTELLERS bis zur vollständigen Zahlung des vereinbarten Kaufpreises seitens des Käufers. Allerdings wird das Risiko des Warenverlusts bereits anlässlich der Lieferung der WARE auf den Käufer übertragen.

6.2. Bei Verkäufen ins Ausland, wenn die Waren im Rahmen normaler Geschäftstätigkeiten des Käufers an Dritte verkauft und geliefert werden, und das Eigentum der Ware noch nicht übertragen wurde, bleibt der Eigentumsvorbehalt des HERSTELLERS gegenüber Dritten wirksam.

6.3. Bei Zahlungsverzug ist der HERSTELLER ohne irgendwelche Förmlichkeiten oder vorherige Mitteilung an den Käufer berechtigt, die gesamte dem Eigentumsvorbehalt unterliegende Ware zurückzunehmen wie auch, falls gesetzlich vorgesehen, alle Schuldverschreibungen gegenüber Dritten, wobei dem HERSTELLER die Geltendmachung der durch den Verzug des Käufers erlittenen oder noch zu erlittenen Schäden anhand aller ihm zur Verfügung stehenden Rechtsmittel vorbehalten bleibt.

7 - Höhere Gewalt

7.1. Der HERSTELLER ist in Fällen höherer Gewalt dem Käufer gegenüber von der vertraglichen Leistungserfüllung, einschließlich einer durchzuführenden oder pünktlichen Lieferung der WARE, befreit. Als Ereignisse höherer Gewalt gelten zum Beispiel die nicht stattgefundenen oder verzögerte Materiallieferung von Lieferanten, Betriebsstörungen, Streiks, Naturereignisse, Ausfall oder Störungen von Transportmitteln bzw. Energie.

8 - Geltendes Recht - Gerichtsstand

8.1. Mangels abweichender Vereinbarung der Vertragsparteien finden bei der Interpretation, Integration oder Richtigstellung der vorliegenden Geschäftsbedingungen die Bestimmungen der Rechtsverordnung Nr. 67/2003 vom 8. April Anwendung.

CONDIÇÕES GERAIS DE VENDA

1 - Aplicabilidade das Condições

1.1. As condições gerais em seguida elencadas e especificadas - de ora em diante denominadas "CONDIÇÕES" -, constituem parte integrante do contrato de compra e venda de mosaicos e outros produtos cerâmicos - de ora em diante designados como o "PRODUTO" ou os "PRODUTOS" - fabricados pela Love Tiles - Gres Panaria Portugal, S.A., também designado como o "FABRICANTE".

1.2. Salvo casos específicos ou excepcionais, em que a aplicação destas condições seja expressamente alterada através de acordo escrito e assinado pelo FABRICANTE, elas representam as condições exclusivas aplicadas a essa venda. Se uma ou mais partes das presentes CONDIÇÕES ou contratos, individualmente considerados e dos quais elas façam parte, forem alguma forma julgadas nulas, inválidas ou inaplicáveis por razões de força maior, as CONDIÇÕES gerais ou particulares permanecerão válidas no seu conjunto, sendo que as condições inválidas serão substituídas por novas disposições que reproduzirão, tanto quanto possível, a intenção original das partes.

2 - Execução do Contrato de Venda - Entrega dos Produtos

2.1. O contrato é celebrado quando a parte poponente ou o comprador tiver conhecimento da aceitação escrita do mesmo pela contraparte.

2.2. Uma encomenda que não tiver sido confirmada por escrito não pode, em nenhuma circunstância, ser considerada como não sido aceite, excepto se tiver sido executada pelo FABRICANTE através do envio ou da entrega dos PRODUTOS. A entrega parcial dos PRODUTOS encomendados não implica a aceitação da totalidade da encomenda, mas apenas da parte dos PRODUTOS que tenham sido efectivamente entregues.

2.3. Excepto se o contrário for expressamente acordado por escrito, a entrega dos PRODUTOS será efectuada exclusivamente no território de Portugal Continental.

2.4. Salvo acordo em contrário, todas as datas que forem indicadas para efeitos de entrega, serão consideradas como datas aproximadas.

3 - Características dos Produtos - Garantia - Reclamações

3.1. Os PRODUTOS fabricados pela Love Tiles - Gres Panaria Portugal, S.A. são produzidos em conformidade com as normas europeias aplicáveis. O FABRICANTE vende exclusivamente a revendedores profissionais, sendo estes responsáveis por prestarem informações técnicas correctas aos utilizadores finais ou aos retalhistas.

A classificação dos PRODUTOS é indicada pelo FABRICANTE no material publicitário e/ou nas tabelas de preços. Em consequência, o comprador deverá usar os PRODUTOS em conformidade com as especificações do FABRICANTE.

Para facilitar a sugestão de uso e adaptar a especificação standart à produção específica do FABRICANTE, sobre todos os produtos, listas de preços ou catálogos existem símbolos específicos que indicam a utilização aconselhada para cada produto por parte do FABRICANTE.

3.2. As diferenças de tonalidade ou crominância eventualmente constáveis não decorrem de defeitos do PRODUTO, sendo sim uma característica específica do material cerâmico que foi submetido a cozedura a altas temperaturas. A característica especial de "resistência à congelação" apenas se aplica aos produtos que o FABRICANTE tenha especificamente garantido para esse efeito através de uma indicação expressa no seu material publicitário e/ou nas tabelas de preços. No caso de inexistência desta indicação, os produtos serão considerados única e exclusivamente para utilização em interior ou, em qualquer caso, para utilização em locais que não estejam expostos a elementos atmosféricos que alterem as características de resistência ou aparência original do PRODUTO (ex.: precipitação atmosférica, sol, humidade, temperaturas baixas, etc.).

3.3. Os mosaicos com as faces polidas podem alterar o seu aspecto quando utilizados no pavimento de divisões que tenham acesso a partir do exterior, ou divisões onde se preveja intensa circulação pedonal. Os mosaicos polidos podem também ser escorregadios, especialmente quando estiverem molhados ou sob o efeito de humidade. Atento a este motivo o FABRICANTE desaconselha a utilização destes PRODUTOS em locais públicos. Para os locais de circulação intensa de pessoas, o comprador apenas deverá adquirir PRODUTOS classificados pelo FABRICANTE como "PEI V" ou "Grés Porcelânico Toda-a-Massa", em particular os PRODUTOS que o FABRICANTE recomendar especificamente para utilização em locais públicos.

3.4. As apresentações dos PRODUTOS em folhetos ou em qualquer outro material promocional do FABRICANTE são meramente ilustrativos e não representam necessariamente o resultado final estético decorrente da instalação desse produto específico.

3.5. O FABRICANTE garante a boa qualidade e a ausência de defeitos nos PRODUTOS fornecidos. A garantia não se aplica aos PRODUTOS classificados pelo FABRICANTE como inferiores à qualidade de 1ª escolha, ou aos stocks de produtos que tenham sido descontinuados, quando forem vendidos a granel ou indicados como lote especial.

3.6. O FABRICANTE não é responsável por quaisquer defeitos e/ou anomalias existentes nos PRODUTOS que não derivem das especificações técnicas dos mesmos, mas antes decorram de uma utilização inadequadas dos PRODUTOS por parte dos adquirentes e/ou de terceiros que actuem em seu nome. Em particular, o FABRICANTE não aceita quaisquer reclamações ou litígios ligados às situações anteriormente descritas.

3.7. As reclamações decorrentes da existência de defeitos patentes ou ocultos terão de ser efectuados por escrito ao FABRICANTE pelo comprador no prazo de 60 dias a contar da data de entrega das mercadorias. A responsabilidade do Fabricante por defeitos inerentes aos produtos entregues ao comprador fica expressamente limitado ao prazo de 2 anos a contar da data de recepção do bem pelo comprador.

3.8. Em geral, a garantia apenas se aplica aos defeitos detectados em produtos que ainda não foram aplicados. Relativamente aos defeitos detectados após os PRODUTOS terem sido aplicados, a garantia apenas pode aplicar-se se o FABRICANTE tiver confirmado que a colocação do PRODUTO foi efectuada em conformidade com as melhores regras da actividade (DIN 18352), bem como de acordo com os procedimentos descritos no manual de aplicação e manutenção do FABRICANTE.

3.9. A garantia concedida pelo FABRICANTE limita-se à substituição dos produtos defeituosos por outros produtos do mesmo tipo sem defeito, acrescida das despesas de transporte. É expressamente excluído o reembolso de quaisquer outros custos e/ou despesas e em particular os custos de demolição e recolocação. Em qualquer caso, a garantia do FABRICANTE não pode ultrapassar em cinco vezes o valor do material reclamado, até um valor máximo de 10.000 Euros.

3.10. O FABRICANTE não é responsável por quaisquer reclamações devidas a uma classificação de materiais cerâmicos efectuada por organismos de certificação e controlo e diferentes dos europeus indicados no artigo 3.1, com base em especificações técnicas que não correspondam às indicadas pelo FABRICANTE. Qualquer eventual análise técnica especializada solicitada pelo comprador será baseada na correspondência dos materiais vendidos com as características técnicas indicadas pelo FABRICANTE, nesse momento em vigor em Portugal.

4 - Preços e Condições de Pagamento

4.1 Os preços de venda dos PRODUTOS são os indicados na tabela de preços do FABRICANTE vigente à data de confirmação da encomenda. Para contratos de venda com entregas separadas, o preço será o constante da tabela de preços em vigor à data de cada uma das entregas, excepto se as partes contraentes dispuserem por escrito em sentido diverso.

Para os PRODUTOS destinados a mercados estrangeiros o preço será calculado, por indicação do FABRICANTE, na moeda estrangeira do país de destino ou em Euros.

4.2. Excepto se o contrário for expressamente acordado, os pagamentos serão efectuados através de transferência bancária, no prazo de 30 dias a contar da data da factura. Todas as despesas bancárias e de transferência correm por conta do comprador. No caso de atraso na realização do pagamento o FABRICANTE, juntamente com quaisquer outros prejuízos, terá direito, sem necessidade de aviso prévio ao comprador, a aplicar uma taxa de juros de mora e punitivos equivalente à taxa EURIBOR a 6 meses acrescida de 5%.

5 - Agentes do Fabricante

5.1. Os agentes do FABRICANTE promovem a venda dos PRODUTOS e não estão autorizados a agir em nome e por conta do FABRICANTE, excepto no caso de obterem auto-rização específica expressa para o efeito.

5.2. As encomendas recebidas pelos agentes não vinculam o FABRICANTE e deverão, portanto, ser expressamente aceites por escrito pelo próprio FABRICANTE.

6 - Reserva de Propriedade

6.1. É acordado entre as partes que a venda dos PRODUTOS seja efectuada com reserva de propriedade por parte do FABRICANTE até que o pagamento integral do preço acordado esteja integralmente saldado por parte do comprador. No entanto, o risco de perda das mercadorias é transferido para o comprador no momento da entrega dos PRODUTOS.

6.2. No caso de vendas para países estrangeiros, quando as mercadorias são vendidas e entregues a terceiros no âmbito das actividades comerciais normais do Comprador e a propriedade das mercadorias ainda não tiver sido transferida, o direito de reserva de propriedade do FABRICANTE permanece válido perante terceiros.

6.3. No caso de atrasos no pagamento o FABRICANTE tem o direito, sem necessidade de recorrer a qualquer formalidade, incluindo qualquer aviso prévio ao comprador, a recolher todas as mercadorias sujeitas a reserva de propriedade e, se legalmente consagrado, todos os títulos de crédito perante terceiros, ficando expressamente reservado o direito do FABRICANTE recorrer a todos os meios legais ao seu dispor tendo em vista o ressarcimento dos prejuízos que tiver sofrido ou que vier a sofrer em consequência da conduta inadimplente do Comprador.

7 - Caso de Força Maior

7.1. O FABRICANTE não será responsável perante o comprador por qualquer incumprimento do contrato, incluindo a falta de entrega ou a entrega com atraso do PRODUTO, causada por factos que estão fora do seu controlo, como por exemplo, a não entrega ou entrega com atraso de materiais por parte de fornecedores, avarias nas instalações, greves, factos da natureza, interrupções no fornecimento de energia eléctrica, suspensão ou dificuldades de transporte.

8 - Legislação Aplicável - Foro Competente

8.1. Na interpretação, integração ou rectificação das presentes condições vigorarão as disposições constantes do Decreto-Lei Nº 67/2003, de 8 de Abril, que não tenham sido afastadas por acordo das partes.

Technical Information
Information Technique
Technische Information
Техническая Информация
INFORMAÇÃO TÉCNICA

CONDICIONES GENERALES DE VENTA

1 - Aplicabilidad de las Condiciones

1.1. Las condiciones generales a continuación listadas y especificadas - de ahora en adelante denominadas "CONDICIONES" -, constituyen parte integrante del contrato de compra y venta de mosaicos y otros productos cerámicos - de ahora en adelante designados como el "PRODUCTO" o los "PRODUCTOS" - fabricados por Love Tiles - Gres Panaria Portugal, S.A., también designado como el "FABRICANTE".

1.2. Salvo casos específicos o excepcionales, en los que la aplicación de estas condiciones sea expresamente modificada a través de acuerdo escrito y firmado por el FABRICANTE, éstas representan las condiciones exclusivas aplicadas a esa venta. Si una o más partes de las presentes CONDICIONES o contratos, individualmente considerados y de los cuales éstas forman parte, se consideran de alguna forma nulas, no válidas o inaplicables por razones de fuerza mayor, las CONDICIONES generales o particulares permanecerán válidas en su conjunto, de tal forma que las condiciones no válidas se sustituirán por nuevas disposiciones que reproducirán, tanto como sea posible, la intención original de las partes.

2 - Ejecución del Contrato de Venta - Entrega de los Productos

2.1. El contrato se celebra cuando la parte proponente o el comprador tengan conocimiento de la aceptación escrita del mismo por la contraparte.

2.2. Un pedido que no haya sido confirmado por escrito no puede, en ninguna circunstancia, ser considerado como no aceptado, excepto si ha sido realizado por el FABRICANTE a través del envío o de la entrega de los PRODUCTOS. La entrega parcial de los PRODUCTOS pedidos no implica la aceptación de la totalidad del pedido, sino sólo de la parte de los PRODUCTOS que haya sido efectivamente entregada.

2.3. Excepto si lo contrario se acuerda expresamente por escrito, la entrega de los PRODUCTOS se realizará exclusivamente en el territorio de Portugal Continental.

2.4. Salvo acuerdo al contrario, todas las fechas que se indiquen para efectos de entrega se considerarán como fechas aproximadas.

3 - Características de los Productos - Garantía - Reclamaciones

3.1. Los PRODUCTOS fabricados por Love Tiles - Gres Panaria Portugal, S.A. se producen en conformidad con las normas europeas aplicables. EL FABRICANTE vende exclusivamente a revendedores profesionales, siendo estos responsables de prestar informaciones técnicas correctas a los usuarios finales o a los minoristas.

La clasificación de los PRODUCTOS está indicada por el FABRICANTE en el material publicitario y/o en las tablas de precios. Como consecuencia, el comprador deberá usar los PRODUCTOS en conformidad con las especificaciones del FABRICANTE.

Para facilitar la sugerencia de uso y adaptar la especificación estándar a la producción específica del FABRICANTE, sobre todos los productos, listas de precios o catálogos, existen símbolos específicos que indican la utilización aconsejada para cada producto por parte del FABRICANTE.

3.2. Las diferencias de tonalidad o crominancia eventualmente constatables no proceden de defectos del PRODUCTO, siendo sí una característica específica del material cerámico que fue sometido a cocción a altas temperaturas. La característica especial de "resistencia a la congelación" solo se aplica a los productos que el FABRICANTE haya garantizado específicamente para ese efecto a través de una indicación expresa en su material publicitario y /o en las tablas de precios. En el caso de inexistencia de esta indicación, los productos se considerarán única y exclusivamente para utilización en interior o, en cualquier caso, para utilización en lugares que no estén expuestos a elementos atmosféricos que modifiquen las características de resistencia o apariencia original del PRODUCTO (ej.: precipitación atmosférica, sol, humedad, temperaturas bajas, etc.).

3.3. Los mosaicos con las caras pulidas pueden modificar su aspecto cuando se utilizan en el pavimento de divisiones a las que se tenga acceso a partir del exterior, o divisiones en las que se prevea intensa circulación peatonal. Los mosaicos pulidos también pueden ser resbaladizos, especialmente cuando están mojados o bajo el efecto de la humedad. Atento a este motivo, el FABRICANTE desaconseja la utilización de estos PRODUCTOS en lugares públicos. Para los lugares de circulación intensa de personas, el comprador solo deberá adquirir PRODUCTOS clasificados por el FABRICANTE como "PEI V" o "Gres Porcelánico Toda Masa", en particular los PRODUCTOS que el FABRICANTE recomiende específicamente para la utilización en lugares públicos.

3.4. Las presentaciones de los PRODUCTOS en folletos o en cualquier otro material promocional del FABRICANTE son meramente ilustrativos y no representan necesariamente el resultado final estético derivado de la instalación de ese producto específico.

3.5. El FABRICANTE garantiza la buena calidad y la ausencia de defectos en los PRODUCTOS suministrados. La garantía no se aplica a los PRODUCTOS clasificados por el FABRICANTE como inferiores a la calidad de la 1ª elección, o a los stocks de productos que hayan sido descontinuados, cuando se vendan a granel o se indiquen como lote especial.

3.6. El FABRICANTE no es responsable por cualesquier defectos y/o anomalías existentes en los PRODUCTOS que no deriven de las especificaciones técnicas de los mismos, sino que deriven de una utilización inadecuada de los PRODUCTOS por parte de los adquirentes y/o de terceros que actúen en su nombre. En particular, el FABRICANTE no acepta ninguna reclamación o litigio asociado a las situaciones anteriormente descritas.

3.7. Las reclamaciones derivadas de la existencia de defectos patentes u ocultos tendrán que ser efectuadas por escrito al FABRICANTE por el comprador en el plazo de 60 días a contar desde la

fecha de entrega de las mercancías. La responsabilidad del Fabricante por defectos inherentes a los productos entregados al comprador queda expresamente limitada al plazo de 2 años a contar desde la fecha de recepción del bien por el comprador.

3.8. En general, la garantía sólo se aplica a los defectos detectados en productos que aún no se han aplicado. Con respecto a los defectos detectados después de que los PRODUCTOS hayan sido aplicados, la garantía sólo se puede aplicar si el FABRICANTE ha confirmado que la colocación del PRODUCTO se efectuó en conformidad con las mejores reglas de la actividad (DIN 18352), así como de acuerdo con los procedimientos descritos en el manual de aplicación y mantenimiento del FABRICANTE.

3.9. La garantía concedida por el FABRICANTE se limita a la sustitución de los productos defectuosos por otros productos del mismo tipo sin defecto, además de los gastos de transporte añadidos. Está expresamente excluido el reembolso de cualesquier otros costes y/o gastos y en particular los costes de demolición y recolocación. En cualquier caso, la garantía del FABRICANTE no puede superar en cinco veces el valor del material reclamado, hasta un valor máximo de 10.000 Euros.

3.10. El FABRICANTE no es responsable por cualesquier reclamaciones debidas a una clasificación de materiales cerámicos efectuada por organismos de certificación y control diferentes de los europeos indicados en el artículo 3.1, con base en especificaciones técnicas que no correspondan a las indicadas por el FABRICANTE. Cualquier eventual análisis técnico especializado solicitado por el comprador estará basado en la correspondencia de los materiales vendidos con las características técnicas indicadas por el FABRICANTE, en ese momento en vigor en Portugal.

4 - Precios y Condiciones de Pago

4.1. Los precios de venta de los PRODUCTOS son los indicados en la tabla de precios del FABRICANTE vigente a la fecha de confirmación del pedido. Para contratos de venta, con entregas separadas, el precio será el que consta en la tabla de precios en vigor a la fecha de cada una de las entregas, excepto si las partes contrayentes disponen por escrito en sentido diverso.

Para los PRODUCTOS destinados a mercados extranjeros el precio se calculará, por indicación del FABRICANTE, en la moneda extranjera del país de destino o en Euros.

4.2. Excepto si se acuerda expresamente lo contrario, los pagos se efectuarán a través de transferencia bancaria, en el plazo de 30 días a contar desde la fecha de la factura. Todos los gastos bancarios y de transferencia corren por cuenta del comprador. En el caso de retraso en la realización del pago, el FABRICANTE, junto con cualesquier otros perjuicios, tendrá derecho, sin necesidad de aviso previo al comprador, a aplicar una tasa de intereses de demora y punitivos equivalente a la tasa EURIBOR a 6 meses aumentada en un 5%.

5 - Agentes del Fabricante

5.1. Los agentes del FABRICANTE promueven la venta de los PRODUCTOS y no están autorizados a actuar en nombre y por cuenta del FABRICANTE, excepto en el caso de que obtengan autorización expresa para el efecto.

5.2. Los pedidos recibidos por los agentes no vinculan el FABRICANTE y deberán, por lo tanto, ser expresamente aceptados por escrito por el propio FABRICANTE.

6 - Reserva de Propiedad

6.1. Se acuerda entre las partes que la venta de los PRODUCTOS se efectúe con reserva de propiedad por parte del FABRICANTE hasta que el pago integral del precio acordado esté integralmente saldado por parte del comprador. Sin embargo, el riesgo de pérdida de las mercancías se transfiere al comprador en el momento de la entrega de los PRODUCTOS.

6.2. En el caso de ventas para países extranjeros, cuando las mercancías se venden y entregan a terceros en el ámbito de las actividades comerciales normales del Comprador y la propiedad de las mercancías aún no haya sido transferida, el derecho de reserva de propiedad del FABRICANTE permanece válido frente a terceros.

6.3. En el caso de retrasos en el pago, el FABRICANTE tiene el derecho, sin necesidad de recurrir a cualquier formalidad, incluyendo cualquier aviso previo al comprador, a recoger todas las mercancías sujetas a reserva de propiedad y, si está legalmente consagrado, todos los títulos de crédito frente a terceros, quedando expresamente reservado el derecho del FABRICANTE a recurrir a todos los medios legales a su disposición teniendo en vista el resarcimiento de los perjuicios que haya sufrido o que vaya a sufrir como consecuencia de la conducta del Comprador.

7 - Caso de Fuerza Mayor

7.1. El FABRICANTE no será responsable frente al comprador por cualquier incumplimiento del contrato, incluyendo la falta de entrega o la entrega con retraso del PRODUCTO, causada por hechos que están fuera de su control, como por ejemplo, la no entrega o entrega con retraso de materiales por parte de proveedores, averías en las instalaciones, huelgas, sucesos de la naturaleza, interrupciones en el suministro de energía eléctrica, suspensión o dificultades de transporte.

8 - Legislación Aplicable - Foro Competente

8.1. Los contratos de exportación de mercancías, celebrados por el FABRICANTE se rigen, en los casos en los que no sean derogados por las presentes CONDICIONES, por la Convención de Viena de 11 de abril de 1980 sobre Contratos de Compra y Venta Internacional de Mercancías.

8.2. Para cualesquier litigios relativos a la venta de PRODUCTOS del FABRICANTE y sobre cualesquier otras materias, el único Tribunal competente, con expresa renuncia de cualquier otro, será el del lugar donde el FABRICANTE posee su red social, también se aplica esta regla de foro competente en lo que respecta a la ejecución de los títulos de crédito recibidos por el FABRICANTE como medio de pago.



ОСНОВНЫЕ УСЛОВИЯ ПРОДАЖ

1. Применение условия.

1.1. Следующие общие условия (далее — «УСЛОВИЯ») являются неотъемлемой частью договора купли-продажи плитки и других керамических изделий (далее — «ИЗДЕЛИЕ» или «ИЗДЕЛИЯ») производства компании Love Tiles — Grés Panaria Portugal, S.A. (далее — «ПРОИЗВОДИТЕЛЬ»).

За исключением конкретных случаев, когда данные условия прямо отменены подписанным ПРОИЗВОДИТЕЛЕМ письменными соглашениями, они являются исключительными положениями для упомянутых продаж. Если одна или несколько частей настоящих УСЛОВИЙ или отдельные включенные в них положения признаются недействительными, данные УСЛОВИЯ или их отдельные части остаются действительными; недействительные положения подлежат замене новыми соглашениями, которые будут отражать, насколько это возможно, первоначальное намерение сторон.

2. Оформление договора купли-продажи. Поставка изделий

2.1. Договор считается оформленным, когда предлагающей стороне или покупателю становится известно о письменном согласии другой стороны.

2.2. Заказ, который не был подтвержден в письменной форме, ни при каких обстоятельствах не считается принятым, кроме случаев его выполнения ПРОИЗВОДИТЕЛЕМ путем отгрузки или поставки ИЗДЕЛИЙ. Частичная поставка заказанных ИЗДЕЛИЙ не подразумевает принятие всего заказа, а только заказа на фактически поставленную часть ИЗДЕЛИЙ.

2.3. При отсутствии письменного соглашения об обратном поставка ИЗДЕЛИЙ на территории Португалии или за ее пределы осуществляется на условиях «франко-завод». Данное условие поставки, а также другие условия поставки, которые могут быть согласованы в письменной форме, трактуется в соответствии с составленными Международной торговой палатой правилами Инкотермс, действующими на момент продажи.

2.4. Если не оговорено иное, все указанные для поставки даты считаются приблизительными.

3. Гарантия на технические характеристики изделий. Претензии

3.1. ИЗДЕЛИЯ, изготовленные компанией Love Tiles — Grés Panaria Portugal, S.A., произведены в соответствии с европейскими стандартами UNI, DIN и EN. ПРОИЗВОДИТЕЛЬ продает изделия исключительно профессиональным дилерам; они ответственны за предоставление правильной технической информации конечному пользователю или розничным торговцам.

Классификация ИЗДЕЛИЙ указывается ПРОИЗВОДИТЕЛЕМ в рекламных материалах и (или) в прейскурантах. Поэтому покупатель должен использовать ИЗДЕЛИЯ в соответствии со спецификациями ПРОИЗВОДИТЕЛЯ. Для облегчения предоставления рекомендаций по использованию и обеспечения соответствия стандартной классификации конкретной продукции ПРОИЗВОДИТЕЛЯ на каждом изделии, в каждом прейскуранте или каталоге есть специальные знаки, которые указывают целевое использование, рекомендуемое ПРОИЗВОДИТЕЛЕМ.

3.2. Различия в оттенках не являются дефектом ИЗДЕЛИЯ — это специфическая характеристика материала, обжиг которого осуществлялся при высокой температуре. Специальное техническое требование «морозостойкости» относится только к ИЗДЕЛИЯМ, для которых ПРОИЗВОДИТЕЛЬ прямо гарантировал такую характеристику, конкретно указав ее в рекламных материалах и (или) прейскурантах. Не содержащие данное конкретное указание ИЗДЕЛИЯ считаются предназначенными исключительно для внутреннего использования или в любом случае для использования в местах, не подверженных воздействию атмосферных условий. Гарантия морозостойкости предоставляется на срок до двух лет.

3.3. Плитку с полированной поверхностью не следует использовать в помещениях на первом этаже у выхода на улицу, а также в помещениях, где предполагается особенно интенсивный поток людей. Плитка с глянцевой поверхностью может также быть скользкой, особенно если ее поверхность влажная; поэтому ПРОИЗВОДИТЕЛЬ не рекомендует использовать эти ИЗДЕЛИЯ в общественных местах. Для мест, предназначенных для интенсивного пешеходного движения, покупателю следует приобретать только ИЗДЕЛИЯ, классифицированные ПРОИЗВОДИТЕЛЕМ как PEI V, и, в частности, те ИЗДЕЛИЯ, которые ПРОИЗВОДИТЕЛЬ прямо рекомендует для использования в общественных местах.

3.4. Изображения ИЗДЕЛИЙ в рекламных буклетах и других рекламных материалах ПРОИЗВОДИТЕЛЯ являются исключительно наглядными примерами и не обязательно представляют конечный эстетический результат укладки этого конкретного ИЗДЕЛИЯ.

3.5. ПРОИЗВОДИТЕЛЬ гарантирует хорошее качество и отсутствие дефектов поставленных ИЗДЕЛИЙ. Гарантия не распространяется на ИЗДЕЛИЯ, классифицированные ПРОИЗВОДИТЕЛЕМ как изделия ниже высшего сорта, или на запасы ИЗДЕЛИЙ, производство которых прекращено, при продаже насыпью или при указании в качестве специального предложения.

3.6. ПРОИЗВОДИТЕЛЬ не несет ответственности за дефекты и (или) отклонения в ИЗДЕЛИЯХ, которые не являются следствием плохого качества ИЗДЕЛИЙ, а возникли вследствие ненадлежащего использования ИЗДЕЛИЙ покупателями и (или) третьими лицами, действующими от их имени. В частности, ПРОИЗВОДИТЕЛЬ не принимает претензии и не вступает в споры в связи с описанными выше ситуациями.

3.7. О наличии претензий покупатель должен сообщить ПРОИЗВОДИТЕЛЮ в течение 60 (шестидесяти) дней с даты поставки товаров. В случае скрытых дефектов период уведомления равен 60 (шестидесяти) дням с даты выявления такого дефекта. Ни при каких обстоятельствах

ПРОИЗВОДИТЕЛЬ не несет ответственности за дефекты, выявленные через двенадцать месяцев после поставки ИЗДЕЛИЙ первому Покупателю ПРОИЗВОДИТЕЛЯ, и поэтому подача жалобы Покупателем на ПРОИЗВОДИТЕЛЯ ограничена исключительно 2-летним периодом со дня поставки товаров.

3.8. В принципе, гарантия не распространяется на дефект, обнаруженный на еще не уложенных ИЗДЕЛИЯХ. Для скрытых дефектов, обнаруженных после укладки ИЗДЕЛИЙ, гарантия может применяться только при условии подтверждения ПРОИЗВОДИТЕЛЕМ факта укладки ИЗДЕЛИЯ на наивысшем профессиональном уровне (DIN 18352).

3.9. Предоставляемая ПРОИЗВОДИТЕЛЕМ гарантия ограничивается заменой дефектных изделий другими изделиями того же типа без дефектов, а также несением транспортных расходов. Прямо исключается возможность возмещения каких-либо других расходов и (или) затрат, в частности, расходов на демонтаж и повторную укладку. Гарантия ПРОИЗВОДИТЕЛЯ ни при каких обстоятельствах не может превышать пятикратного размера стоимости материала, по которому предъявляется претензия, составляя при этом не более 10 000 евро.

3.10. ПРОИЗВОДИТЕЛЬ не несет ответственности по претензиям вследствие классификации керамических материалов, выполненной органами сертификации и контроля, отличными от европейских, указанных в п. 3.1, на основании технических спецификаций, которые не соответствуют указанным ПРОИЗВОДИТЕЛЕМ техническим спецификациям. Любой возможный запрос покупателя на проведение технической экспертизы должен основываться на соответствии проданных материалов указанным ПРОИЗВОДИТЕЛЕМ техническим спецификациям, действующим на то время в Португалии.

4. Цены и условия оплаты

4.1. Цены реализации ИЗДЕЛИЙ указаны в прейскуранте ПРОИЗВОДИТЕЛЯ, действующем на дату подтверждения заказа. Цена на ИЗДЕЛИЯ, предназначенные для зарубежных рынков, рассчитывается в иностранной валюте страны назначения или в евро, на выбор ПРОИЗВОДИТЕЛЯ.

4.2. Если не оговорено иное, оплата производится покупателем путем банковского перевода в течение 30 дней с момента выставления счета. Все банковские расходы и расходы по выплатам несет покупатель. В случае задержки оплаты ПРОИЗВОДИТЕЛЬ, наряду с возмещением любого другого ущерба, имеет право на получение процентных выплат за просроченный платеж в размере ставки EURIBOR сроком на 6 (шесть) месяцев плюс 5% без предварительного уведомления покупателя.

5. Посредники Производителя

5.1. Посредники ПРОИЗВОДИТЕЛЯ стимулируют продажу изделий и уполномочены действовать от имени и по поручению ПРОИЗВОДИТЕЛЯ исключительно при наличии конкретного письменного разрешения.

5.2. Заказы, собранные посредниками, не являются обязательными для исполнения ПРОИЗВОДИТЕЛЕМ, поэтому они должны быть прямо подтверждены в письменной форме самими ПРОИЗВОДИТЕЛЕМ.

6. Удержание права собственности

6.1. Стороны договорились, что продажа ИЗДЕЛИЙ осуществляется при условии удержания права собственности на них ПРОИЗВОДИТЕЛЕМ до полной выплаты покупателем обусловленной цены. Однако риск утери товаров переходит к покупателю в момент доставки ИЗДЕЛИЙ. В случае продаж в зарубежные страны, когда товары реализуются и поставляются третьим лицам в рамках обычной коммерческой деятельности Покупателя, а право собственности на товары еще не было передано, удержание права собственности на них ПРОИЗВОДИТЕЛЕМ остается в силе также в отношении третьих лиц, если это разрешено законом.

6.2. При задержке выплат ПРОИЗВОДИТЕЛЬ вправе, без каких-либо формальностей, в том числе без предварительного уведомления покупателя, собрать все товары, на которые распространяется право удержания собственности, если это разрешено законом, и все сопутствующие аккредитивы в отношении третьих лиц, прямо сохраняя за собой право обращаться в суд за компенсацией понесенных убытков.

7. Форс-мажор

7.1. ПРОИЗВОДИТЕЛЬ не несет ответственности перед покупателем за неисполнение контракта, в том числе за невыполнение или задержку поставки, вызванное событиями, не подлежащими разумному контролю ПРОИЗВОДИТЕЛЯ, такими как, например, невыполнение или задержка поставки рабочих материалов поставщиками, неисправности в работе фабрики, забастовки или другие профсоюзные действия, перебои с энергоснабжением, приостановка или трудности в работе транспорта.

8. Действующее законодательство. Компетентный суд

8.1. Договора о продаже на экспорт, стороной которых является ПРОИЗВОДИТЕЛЬ, регулируются, если это не отменено настоящими УСЛОВИЯМИ, Венской конвенцией о международных договорах купли-продажи товаров от 11 апреля 1980 г.

8.2. В случае споров, связанных с продажей ИЗДЕЛИЙ ПРОИЗВОДИТЕЛЯ и всеми другими сопутствующими вопросами, единственным компетентным судом является суд по месту регистрации ПРОИЗВОДИТЕЛЯ, это также касается принудительного обеспечения выполнения обязательств по аккредитивам, полученным ПРОИЗВОДИТЕЛЕМ в качестве средства платежа.



LOVE

CERAMIC TILES

ZONA INDUSTRIAL DE AVEIRO
3801-101 AVEIRO . PORTUGAL
T. (+351) 234 30 30 30
F. (+351) 234 30 30 31
LOVETILES@LOVETILES.COM
WWW.LOVETILES.COM

Edição
Edition
Ausgabe
издание

01 . 2016

Coordenação
Coordination
Coordination
Координирование



MARKETING LOVE TILES

Design e Produção
Design and Production
Design et Production
Design und Produktion
Дизайн и Производство



www.viriato.com.pt



© COPYRIGHT GRÉS PANARIA PORTUGAL S.A.

OS PRODUTOS E MARCAS REFERIDOS OU REPRESENTADOS NESTE CATÁLOGO SÃO PROPRIEDADE DA GRES PANARIA PORTUGAL, S.A., ESTANDO AS MARCAS, DESENHOS, FOTOGRAFIAS OU TEXTOS DEVIDAMENTE PROTEGIDOS POR LEI. É EXPRESSAMENTE PROIBIDA A CÓPIA, IMITAÇÃO, ALTERAÇÃO, NO TODO OU EM PARTE, DE QUALQUER ELEMENTO CONSTITUTIVO OU REPRESENTATIVO DAS MARCAS, DESIGNADAMENTE PALAVRAS, SÍMBOLOS, CORES OU OUTROS, BEM COMO DOS LOGÓTIPOS, DESENHOS, LAYOUTS DE CATÁLOGO, AMBIENTES DE DESIGN OU DECORAÇÃO NELE REPRESENTADOS GRAFICAMENTE, SEM AUTORIZAÇÃO ESCRITA DA GRES PANARIA PORTUGAL, S.A.. A VIOLAÇÃO DE ALGUMA DAS DISPOSIÇÕES PREVISTAS NESTA DECLARAÇÃO PODERÁ ACARREJAR RESPONSABILIZAÇÃO CIVIL E CRIMINAL DO INFRACTOR.

ALL RIGHTS RESERVED. THE PRODUCTS AND BRANDS MENTIONED OR REPRESENTED IN THIS CATALOGUE ARE PROPERTY OF GRES PANARIA PORTUGAL, S.A., ALL BRANDS, DRAWINGS, PHOTOGRAPHS AND TEXTS ARE PROTECTED BY LAW. IT IS STRICTLY PROHIBITED TO COPY, IMITATE OR MODIFY IN ITS WHOLE OR PARTIALLY ANY ELEMENT INHERENT TO THE REPRESENTATION OF THE BRANDS, NAMELY WORDS, SYMBOLS, COLOURS OR OTHERS, AS WELL AS LOGOTYPES, DRAWINGS, CATALOGUE LAYOUT, DESIGN ATMOSPHERES OR DECORATION GRAPHICALLY REPRESENTED IN THE CATALOGUE, WITHOUT PRIOR WRITTEN CONSENT OF GRES PANARIA PORTUGAL S.A.. THE INFRINGEMENT OF THE DISPOSITIONS DEFINED IN THIS DECLARATION MAY RESULT IN THE CIVIL AND CRIMINAL RESPONSABILIZATION OF THE INFRACTOR.

LES PRODUITS ET LES MARQUES MENTIONNÉS OU REPRÉSENTÉS DANS CE CATALOGUE SONT LA PROPRIÉTÉ DE L'ENTREPRISE GRES PANARIA PORTUGAL, S.A., LES MARQUES, LES DESSINS, LES PHOTOGRAPHIES OU LES TEXTES SONT DUMENT PROTÉGÉS PAR LA LOI. TOUTE REPRODUCTION, IMITATION OU MODIFICATION PARTIELLE OU TOTALE DE MOTS, SYMBOLES, COULEURS OU AUTRES ÉLÉMENTS TOUT COMME LES LOGOTYPES, DESSINS, MISE EN PAGE DES CATALOGUES, AMBIANCES DE DESIGN OU DÉCORATION REPRÉSENTÉES AU NIVEAU GRAPHIQUE, SONT STRICTEMENT INTERDITES, SAUF SUR AUTORISATION ÉCRITE AU PRÉALABLE DE L'ENTREPRISE GRES PANARIA PORTUGAL, S.A.. LA VIOLATION D'UNE DE CES DISPOSITIONS PRÉVUES DANS CETTE DÉCLARATION SERA DE LA RESPONSABILITÉ CIVILE ET CRIMINELLE DU TRANSGRESSEUR.

DIE IN DIESEM KATALOG GENANNTEN ODER DARGESTELLTEN PRODUKTE UND MARKEN SIND EIGENTUM DER GRES PANARIA PORTUGAL S.A.. DIE MARKEN, DESIGNS, ZEICHNUNGEN, FOTOGRAFIEN UND TEXTE SIND GESETZLICH GESCHÜTZT. KOMPLETTE ODER TEILWEISE KOPPIEN, NACHAHMUNGEN, ÄNDERUNGEN IRGENDNEINES KONSTITUTIVEN ODER REPRÄSENTATIVEN ELEMENTS DER MARKEN, NAMENLICH WÖRTER, SYMBOLE, FARBEN ODER ANDERER ELEMENTE, SOWIE LOGOS, ZEICHNUNGEN, DESIGNS, LAYOUTS VON KATALOGEN, DESIGN- AMBIENTEN ODER IN DIESEN DARGESTELLTEN DEKORATIONEN SIND OHNE SCHRIFTLICHE GENEHMIGUNG DER GRES PANARIA PORTUGAL S.A. AUSDRÜCKLICH VERBOTEN. DIE VERLETZUNG IRGENDNEINER IN DIESER ERKLÄRUNG ANGEGEBENEN BESTIMMUNGEN KANN ZU EINER ZIVIL- UND STRAFRECHTLICHEN VERFOLGUNG DES VERLETZENDEN FÜHREN.

ПРОДУКТЫ И БРЕНДЫ, УПОМЯНУТЫЕ ИЛИ ПРЕДСТАВЛЕННЫЕ В ДАННОМ КАТАЛОГЕ, ЯВЛЯЮТСЯ СОБСТВЕННОСТЬЮ GRES PANARIA PORTUGAL, S.A., ФИРМЕННЫЕ МАРКИ, РИСУНКИ, ФОТОГРАФИИ ИЛИ ТЕКСТЫ НАДЛЕЖАЩИМ ОБРАЗОМ ЗАЩИЩЕНЫ ЗАКОНОМ. ЗАПРЕЩАЕТСЯ КОПИРОВАНИЕ, ПОДРАЖАНИЕ, ПОПРАВКИ, ПОЛНОСТЬЮ ИЛИ ЧАСТИЧНО, ЛЮБОГО СОСТАВЛЯЮЩЕГО ЭЛЕМЕНТА ФИРМЕННЫХ МАРОК, В ТОМ ЧИСЛЕ СЛОВ, СИМВОЛОВ, ЦВЕТОВ И ДРУГИХ, А ТАКЖЕ ЛОГОТИПОВ, РИСУНКОВ, МАКЕТА КАТАЛОГА, ЕГО ОФОРМИТЕЛЬНОГО ДИЗАЙНА И СООТВЕТСТВУЮЩИХ ГРАФИЧЕСКИХ ДЕКОРАТИВНЫХ ЭЛЕМЕНТОВ, БЕЗ ПИСЬМЕННОГО РАЗРЕШЕНИЯ GRES PANARIA PORTUGAL, S.A.. НАРУШЕНИЕ ЛЮБОГО ИЗ ПОЛОЖЕНИЙ ЭТОГО ЗАЯВЛЕНИЯ МОЖЕТ ПРИВЕСТИ К ГРАЖДАНСКОЙ И УГОЛОВНОЙ ОТВЕТСТВЕННОСТИ ПРАВОНАРУШИТЕЛЯ.

LOVE
CERAMIC TILES