

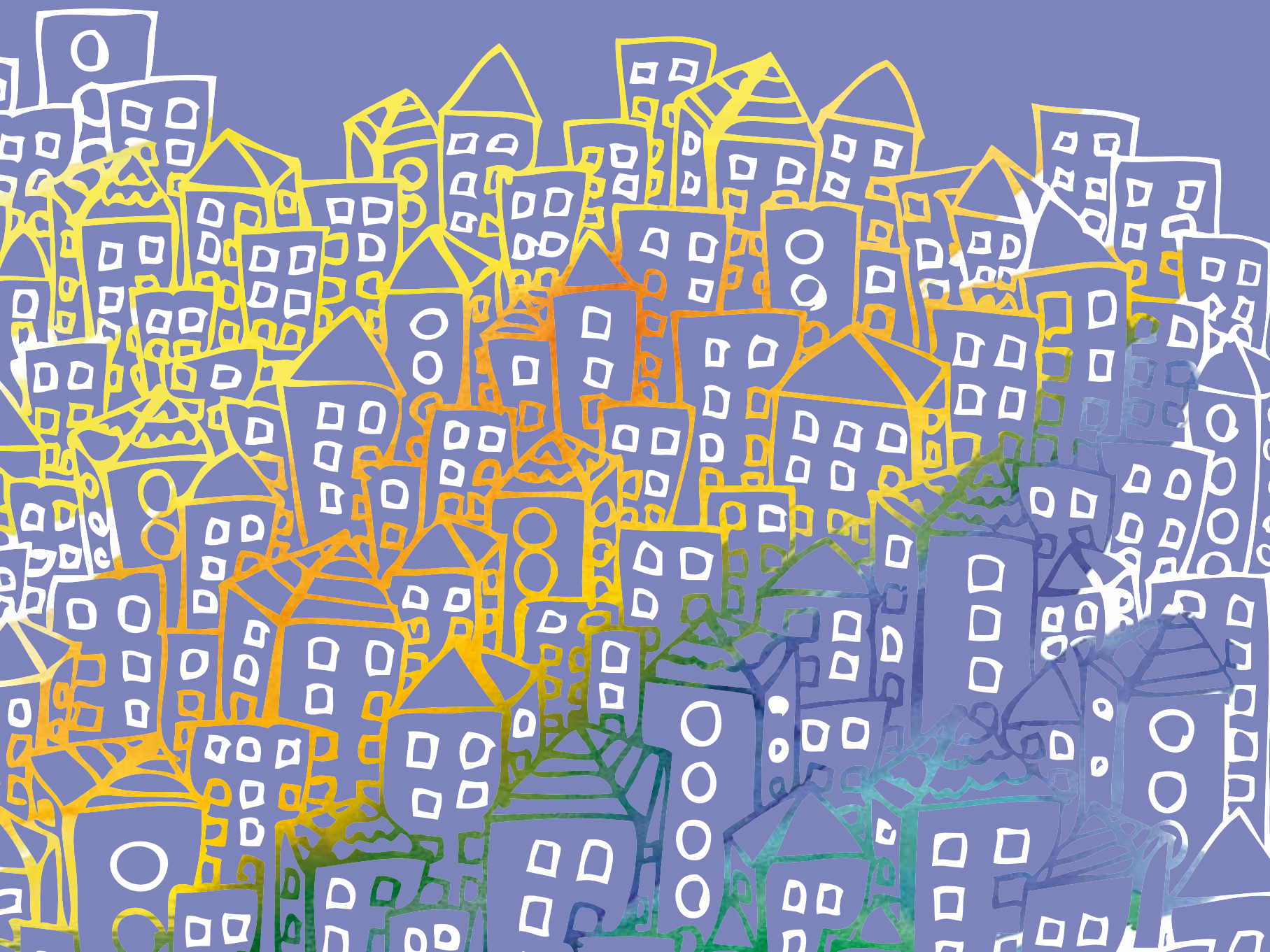

Dado Ceramica

catalogo prodotti





Dado Ceramica

La bellezza è nelle cose che lasciano un segno,

quelle che si ricordano, che affasciano e che sorprendono.

La bellezza è nel particolare che rapisce, che lusinga, che rende unici. Dado Ceramica vuole lasciare un segno, interpretando il vivere contemporaneo come un dialogo perenne fra eleganza, stile e creatività.

Beauty lies in those objects that make their mark on the memory, those able to astound and to appeal. Beauty lies in those unique, seductive details that leave us rapt. Dado Ceramica's aim is to leave our mark, by interpreting contemporary lifestyle as an ongoing dialogue between elegance, style and creativity. In this catalogue there are 31 collections on the catwalk, revealing new ways of adding a personal touch to living spaces. These are Dado Ceramica surfaces: a kaleidoscope of ideas, ongoing aesthetic research, a dialogue between colour and material, textures offsetting decorations in order to inspire architects and interior designers and bring a uniquely beautiful touch to rooms.

La beauté réside dans les choses qui laissent une trace, celles qui se souviennent, qui fascinent et qui surprennent. La beauté réside dans le détail qui frappe, qui flatte et qui rend unique. Dado Ceramica souhaite laisser un signe en interprétant la vie contemporaine comme un dialogue éternel entre élégance, style et créativité. 31 collections défilent dans ce catalogue en révélant une nouvelle façon de personnaliser les espaces. Il s'agit des surfaces de Dado Ceramica: un kaléidoscope de propositions, une recherche esthétique continue, un dialogue entre la couleur et la matière, un contraste entre les textures et les décorations pour inspirer les architectes et les designers d'intérieurs ainsi que pour exalter les environnements grâce à une touche d'unicité.

Die Schönheit findet man in allem, was Spuren hinterlässt, an das wir uns erinnern, das uns fasziniert und überrascht. Die Schönheit liegt im Detail, das uns fesselt, schmeichelt und einzigartig macht. Dado Ceramica möchte ein Zeichen setzen, indem es das zeitgenössische Wohnen wie einen ständigen Dialog zwischen der Eleganz, dem Stil und der Kreativität interpretiert. 31 Kollektionen posieren in diesem Katalog und offenbaren dabei eine neue Art der persönlichen Gestaltung der Räume. Es handelt sich um die Oberflächen von Dado Ceramica: ein Kaleidoskop an Vorschlägen, eine ständige Suche bezüglich der Ästhetik, ein Dialog zwischen der Farbe und dem Material, ein Gegensatz zwischen den Texturen und den Dekorelementen, um Architekten und Innendesigner zu inspirieren und die Ambienzen mit einem Hauch Einzigartigkeit zu unterstreichen.



31 collezioni sfilano in questo catalogo, svelando un nuovo modo di personalizzare gli spazi. Sono le superfici di Dado Ceramica: un caleidoscopio di proposte, una ricerca estetica continua, un dialogo fra il colore e la materia, un contraltare fra le texture e i decori, per ispirare architetti ed interior designer, per esaltare gli ambienti con un tocco di unicità.

galana

guide - guide - Führung

Nome Serie
Series Name
Nom de la série
Serie Name

Tecnologia
Technology
Technologie

Nome Serie
Series Name
Nom de la série
Serie Name

galana Gres porcellanato ingelivo / Frost resistant porcelain stoneware / Gres cérame résistant au gel / Frostbeständiges Feinsteinzeug

IN R10 PEI IV Beige

301329/23 48 ■ 302407/27 46 ■
Galana Beige IN 15,5x31 14 ☉ Galana Beige IN 15,5x31 17 ☉

302410/31 13 ■
Galana Beige IN 15,5x15,5 34 ☉

OUT R12 PEI V

301310/23 48 ■ 301312/27 46 ■
Galana Beige OUT 15,5x31 14 ☉ Galana Beige OUT 15,5x31 17 ☉

301334/31 13 ■ 301343/113 71 ■
Galana Beige OUT 15,5x15,5 34 ☉ Mosaico Mattoncino Galana Beige OUT 15,5x31 (su rete) 23 ☉

IN R10 PEI IV Melange

301330/23 48 ■ 302408/27 46 ■
Galana Melange IN 15,5x31 14 ☉ Galana Melange IN 15,5x31 17 ☉

302411/31 13 ■
Galana Melange IN 15,5x15,5 34 ☉

OUT R12 PEI V

301311/23 48 ■ 301314/27 46 ■
Galana Melange OUT 15,5x31 14 ☉ Galana Melange OUT 15,5x31 17 ☉

301336/31 13 ■ 301344/113 71 ■
Galana Melange OUT 15,5x15,5 34 ☉ Mosaico Mattoncino Galana Melange OUT 15,5x31 (su rete) 23 ☉

Cotto

302413/23 48 ■ 302418/27 46 ■
Galana Cotto IN 15,5x31 14 ☉ Galana Cotto IN 15,5x31 17 ☉

302414/23 48 ■ 302415/27 46 ■
Galana Cotto OUT 15,5x31 14 ☉ Galana Cotto OUT 15,5x31 17 ☉

302419/31 13 ■ 302416/31 13 ■
Galana Cotto IN 15,5x15,5 34 ☉ Galana Cotto OUT 15,5x15,5 34 ☉

Grigio

301308/23 48 ■ 302409/27 46 ■
Galana Grigio IN 15,5x31 14 ☉ Galana Grigio IN 15,5x31 17 ☉

301309/23 48 ■ 301312/27 46 ■
Galana Grigio OUT 15,5x31 14 ☉ Galana Grigio OUT 15,5x31 17 ☉

302412/31 13 ■ 301336/31 13 ■ 301345/113 71 ■
Galana Grigio IN 15,5x15,5 34 ☉ Galana Grigio OUT 15,5x15,5 34 ☉ Mosaico Mattoncino Galana Grigio OUT 15,5x31 (su rete) 23 ☉

Pezzi speciali / Special trims / Pièces spéciales / Spezielle Teile

800155/16 51 ■ Elemento a Elle Galana Beige OUT 31x16,5x6 8 ☉

800157/16 51 ■ Elemento a Elle Galana Melange OUT 31x16,5x6 8 ☉

800156/16 51 ■ Elemento a Elle Galana Grigio OUT 31x16,5x6 8 ☉

800246/16 51 ■ Elemento a Elle Galana Cotto OUT 31x16,5x6 8 ☉

Battiscopa 75x31 46 ☉

800158/04 Galana Beige 47 ■ 800159/04 Galana Grigio 47 ■

Torello 31 8 ☉

800844/22 Galana Beige 42 ■ 800845/22 Galana Melange 42 ■ 800846/22 Galana Grigio 42 ■

Torello Angolare 31 4 ☉

800840/42 Galana Beige 79 ■ 800841/42 Galana Cotto 79 ■ 800842/42 Galana Melange 79 ■ 800843/42 Galana Grigio 79 ■

110 **galana** 111

Tabella pesi e imballi
Table weight and sizes
Tableau poids et mesures
Tabelle gewichte und verpackungen

Pezzi speciali
Special trims
Pièces spéciales
Spezielle Teile

Prodotto / Product / Produit / Produkt

Fondo
Tile
Fonds
Fonds



Codice / Code / Code / Code

301428/55

97 ■

Descrizione / Description / Description / Beschreibung

Star Brown Rett. Lapp. PEI III

Categoria prezzo al mq / Price per sq.m. category
Catégorie prix au m² / Kategorie Preis pro m²

Formato cm / Cm size / Taille cm / Größe cm

44,25x44,25

7 ☉

Sistema PEI / PEI System
Système de PEI / PEI-System
Pezzi per scatola / Pieces per box
Pièces par boîte / Stück pro Karton

Pezzi speciali
Special trims
Pièces spéciales
Spezielle Teile



201343/09

26 ■

List. Glossy Bianco

4,5x20

12 ☉

Categoria prezzo al pezzo
Price per piece category
Catégorie prix à la pièce / Kategorie Preis pro Stück



V1
Prodotto monocromatico.
The least amount of shade and texture variation. Attainable in naturally fired clay products / Produit monochromatique / Einfarbiges Produkt.



V2
Prodotto con leggera variazione cromatica.
Light to moderate shade / Produit à légère variation chromatique / Produkt mit leichter Farbnuance.



V3
Prodotto con marcata variazione cromatica.
High shade texture variation within each carton / Produit à variation chromatique accentuée / Produkt mit ausgeprägter Farbnuance.



V4
Prodotto con forte variazione cromatica.
Very high shade and texture variation within each carton / Produit à forte variation chromatique / Produkt mit starker Farbnuance.

Grado di variazione cromatica
Degree of colour change
Degré de variation chromatique
Grad der Farbabweichung

Century.....	7 - 12
Cementi.....	13 - 24
Loft.....	25 - 30
Marmi Nobili.....	31 - 60
Graniti.....	61 - 64
Stardust.....	65 - 74
Quarzite.....	75 - 82
The Big Apple.....	83 - 88
Rovere / Rovere OUT.....	89 - 106
Galana.....	107 - 114
Wake Up.....	115 - 124
Perlage.....	125 - 128
I Bianchi 25x60.....	129 - 134
Shade.....	135 - 144
Silk.....	145 - 150
Preziosa.....	151 - 156
Kolora.....	157 - 166
City.....	167 - 170
Verve.....	171 - 180
Notte Brava.....	181 - 206
Quark.....	207 - 214
Venice.....	215 - 222
1000tracce.....	223 - 230
Rock.....	231 - 236
Beauty Matt.....	237 - 244
Beauty Line.....	245 - 254
Dolce Amore.....	255 - 260
Seta.....	261 - 266
Unicolor.....	267 - 268
Sale e Pepe.....	269 - 270
Hard Rocks.....	271 - 273

Istruzioni per l'installazione	
Notte Brava.....	201 - 206
Caratteristiche tecniche.....	274 - 277
Marchio di qualità.....	280
Consigli di posa, pulizia e manutenzione.....	281 - 285
Condizioni di vendita.....	286 - 287

index

index - index - index



Prodotto con forte variazione cromatica.
Very high shade and texture variation within each carton /
Produit à forte variation chromatique / Produkt mit starker
farbnuance.

century

Gres porcellanato smaltato
Glazed porcelain stoneware
Grès cérame émaillé
Glasiertes Feinsteinzeug

21,25x85
8"x33"

century

7 - 12



Century Beige



Century Noce



Century Grigio



Timberland® Store Modena

Century Rosso



Century Grigio



Century Rosso



302805/48 56 ■
Century Beige PEI IV
21,25x85 7



302807/48 56 ■
Century Noce PEI IV
21,25x85 7



302808/48 56 ■
Century Rosso PEI IV
21,25x85 7



302806/48 56 ■
Century Grigio PEI IV
21,25x85 7

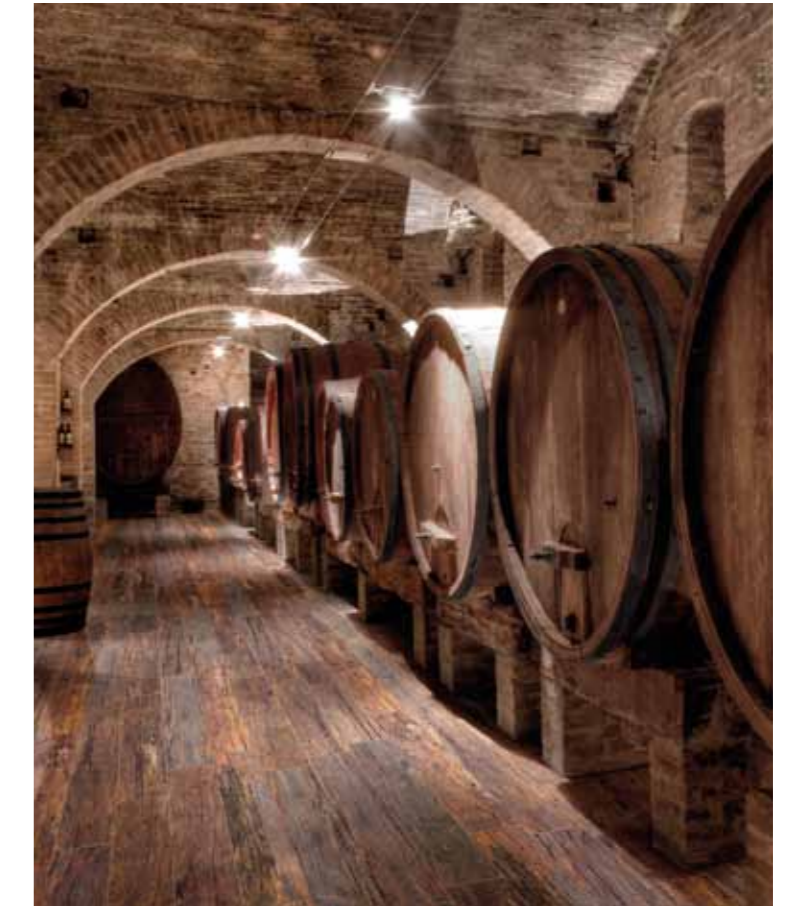

Schemi di posa / Laying patterns / Schémas de pose / Verlegungsschemen

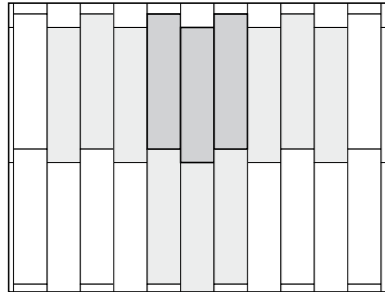

Si consiglia di posare il materiale sfalsato di 1/10 (6,2 cm).
We recommend laying the material in a 1/10 (6,2 cm) staggered arrangement.
Il est conseillé de poser le matériau avec un décalage de 1/10 (6,2 cm).
Es wird empfohlen, das Material um 1/10 (6,2 cm) versetzt zu verlegen.

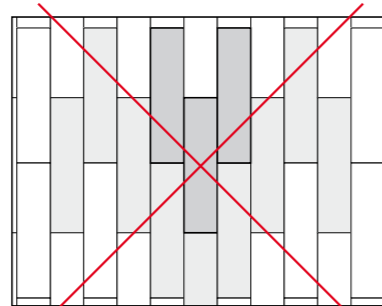

Non è consigliabile posare il materiale sfalsato di 1/2 (31 cm).
We do not recommend laying the material in a 1/2 (31 cm) staggered pattern.
Il est déconseillé de poser le matériau avec un décalage de 1/2 (31 cm).
Es ist nicht empfehlenswert, das Material 1/2 (31 cm) versetzt zu verlegen.

Pezzi speciali / Special trims / Pièces spéciales / Spezielle Teile

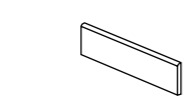

Battiscopa 10x85 6 ■
800361/11 Century Beige 33 ■
800363/11 Century Noce 33 ■
800364/11 Century Rosso 33 ■
800362/11 Century Grigio 33 ■

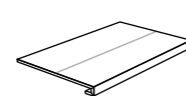

* Gradino Frontale/120 105 ■
42,5x85 1

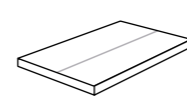

* Gradino Angolare DX/186 73 ■
* Gradino Angolare SX/186 73 ■
42,5x85 1

note / notes / notes / notes

* Disponibili solo su ordinazione
Available on demande / Disponible uniquement a la commande / Nur auf Bestellung.



pesi e misure / weight and sizes / poids et mesures / Gewichte und Verpackungen

dimensioni sizes dimensions abmessungen	spessore thickness épaisseur stärke	pz/collo pcs/box pc/boite stk/ktn	mq/collo sqm/box m/boite qm/ktn	kg/collo kg/box kg/boite kg/ktn	colli/europal box/europal boites/europal ktn/europal	mq/europal sqm/europal m/europal qm/europal	kg/europal kg/europal kg/europal kg/europal
Fondo 21,25x85	10 mm	6	1,08	21,70	60	64,80	1320



TT0966 Espositore serie Century
 cm 51x115x142 1
 Pannelli cm 51x117 4

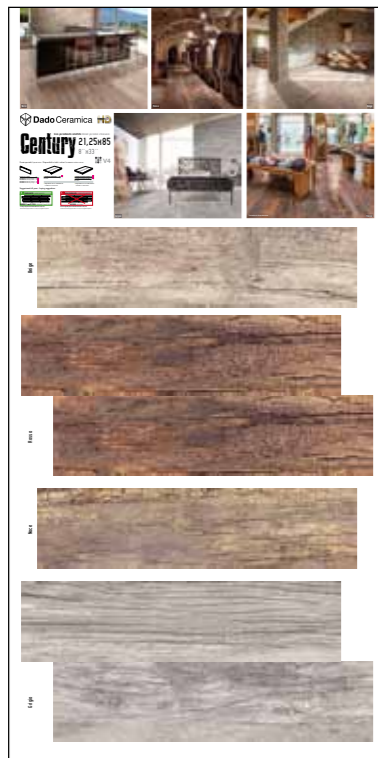

TTP096 Pannello Sinottico Riassuntivo serie Century
 cm 100x200



TTP097 Pannello Sinottico Posato serie Century
 cm 100x200



Prodotto con leggera variazione cromatica.
 Light to moderate shade / Produit à légère variation
 chromatique / Produkt mit leichter Farbnuance.

cementi

mix & match

Pavimento e Rivestimento in gres porcellanato
 smaltato rettificato e colorato in massa

Coloured-body rectified, glazed porcelain stoneware wall and floor
 coverings

Revêtement et sol en grès cérame émaillé rectifié pleine masse
 Verkleidung und Fußboden aus glasiertem, geschliffenem,
 Gefärbte Masse Feinsteinzeug

**5x60 - 10x60 - 15x60 - 30x60 - 60x60 - 62x62 -
 42,5x85 - 41,5x83
 2"x24" - 4"x24" - 6"x24" - 12"x24" - 24"x24" - 24"x24" -
 17"x34" - 16"x33"**





Schemi di posa / Laying patterns / Schémas de pose / Verlegungsschemen

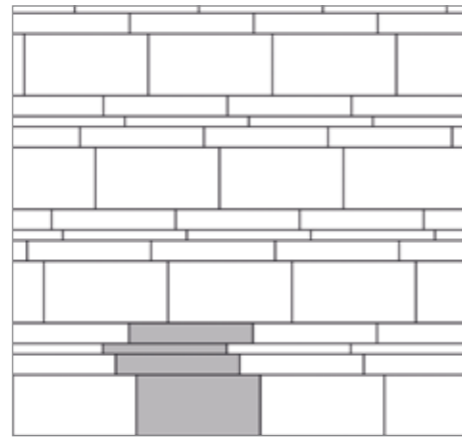

PRODUCTS
 CEMENTI White 5x60 cm - 10x60 cm - 30x60 cm
 CEMENTI Grey 5x60 cm - 10x60 cm - 30x60 cm
 CEMENTI Fog 5x60 cm - 10x60 cm - 30x60 cm

SCHEMA DADO 11
 9%/mq 5x60 cm
 36%/mq 10x60 cm
 55%/mq 30x60 cm

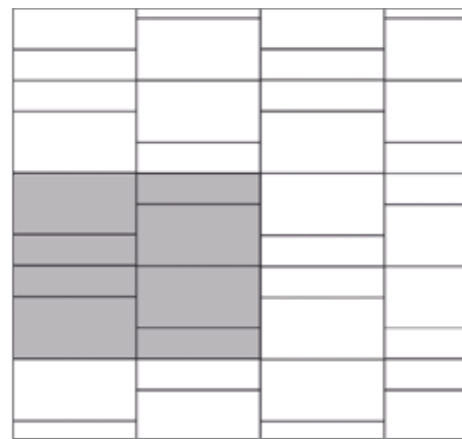

PRODUCTS
 CEMENTI Beige 15x60 cm - 30x60 cm
 CEMENTI Sand 15x60 cm - 30x60 cm
 CEMENTI Taupe 15x60 cm - 30x60 cm
 CEMENTI Mud 15x60 cm - 30x60 cm
 CEMENTI White 15x60 cm - 30x60 cm
 CEMENTI Grey 15x60 cm - 30x60 cm
 CEMENTI Fog 15x60 cm - 30x60 cm
 CEMENTI Black 15x60 cm - 30x60 cm

SCHEMA DADO 12
 33%/mq 15x60 cm
 67%/mq 30x60 cm

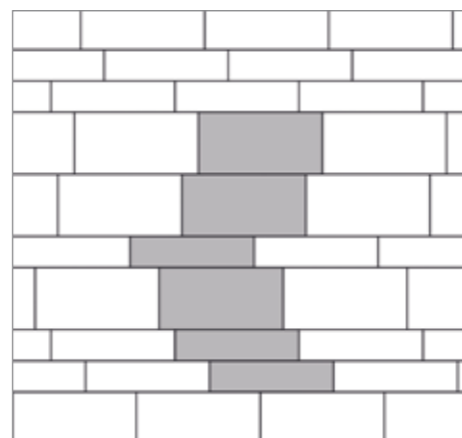

PRODUCTS
 CEMENTI Sand 15x60 cm - 30x60 cm
 CEMENTI Taupe 15x60 cm - 30x60 cm
 CEMENTI Mud 15x60 cm - 30x60 cm

SCHEMA DADO 13
 33%/mq 15x60 cm
 67%/mq 30x60 cm

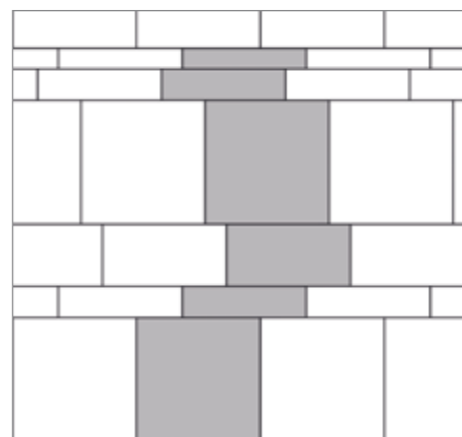

PRODUCTS
 CEMENTI
 Fog 10x60 cm - 15x60 cm - 30x60 cm - 60x60 cm

SCHEMA DADO 14
 5%/mq 10x60 cm
 16%/mq 15x60 cm
 16%/mq 30x60 cm
 63%/mq 60x60 cm

note / notes / notes / anmerkungen

Nella realizzazione di tutti gli schemi mix&match è indispensabile utilizzare una fuga di 1,5 mm per mantenere la continuità della posa con altri formati.
 When creating all types of mix&match laying schemes joints of at least 1.5 mm must be used in order to maintain continuity with other laying formats.

Schemi di posa / Laying patterns / Schémas de pose / Verlegungsschemen

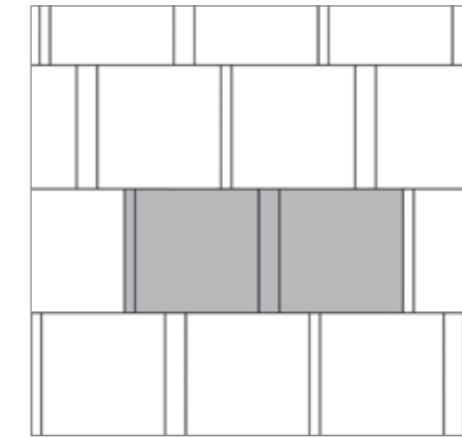
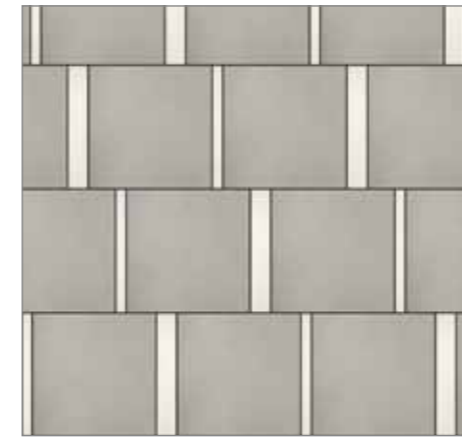

PRODUCTS
 CEMENTI White 5x60 cm - 10x60 cm
 CEMENTI Grey 60x60 cm

SCHEMA DADO 15
 4%/mq 5x60 cm
 7%/mq 10x60 cm
 89%/mq 60x60 cm

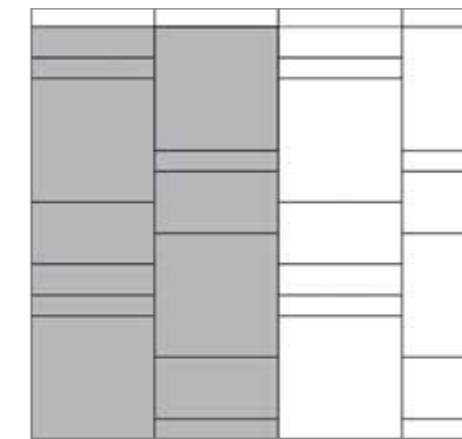

PRODUCTS
 CEMENTI
 White 10x60 cm - 15x60 cm - 30x60 cm - 60x60 cm
 Grey 10x60 cm - 15x60 cm - 30x60 cm - 60x60 cm
 Fog 10x60 cm - 15x60 cm - 30x60 cm - 60x60 cm
 Black 10x60 cm - 15x60 cm - 30x60 cm - 60x60 cm

SCHEMA DADO 16
 10%/mq 10x60 cm
 7%/mq 15x60 cm
 23%/mq 30x60 cm
 60%/mq 60x60 cm

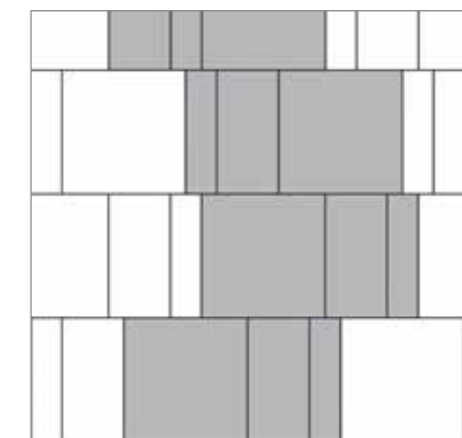
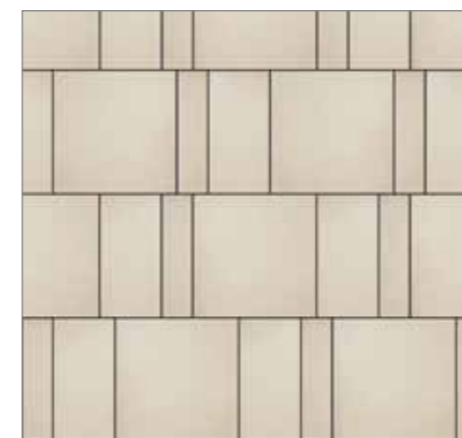

PRODUCTS
 CEMENTI Taupe 15x60 cm - 30x60 cm - 60x60 cm

SCHEMA DADO 17
 16%/mq 15x60 cm
 28%/mq 30x60 cm
 56%/mq 60x60 cm

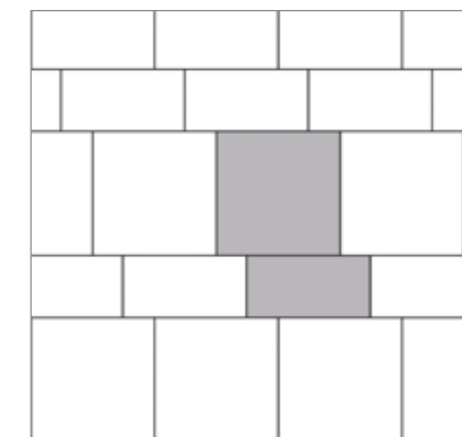

PRODUCTS
 CEMENTI White 30x60 cm - 60x60 cm
 CEMENTI Grey 30x60 cm - 60x60 cm
 CEMENTI Fog 30x60 cm - 60x60 cm
 CEMENTI Black 30x60 cm - 60x60 cm

SCHEMA DADO 18
 33%/mq 30x60 cm
 67%/mq 60x60 cm

note / notes / notes / anmerkungen

Pour réaliser tous les schémas mix et match il est indispensable de faire un joint de 1,5 mm afin de garder une continuité de pose avec les autres formats.
 In der Umsetzung aller Maßnahmen "Mix & Match" ist es notwendig eine 1,5 mm breite Fuge zu benutzen damit die Kontinuität der Verlegung mit den anderen Formaten eingehalten werden kann.

Colori / Colour / Couleurs / Farben

Beige

Sand

Taupe

Mud

White

Grey

Fog

Black

Fondi / Base tiles / Fonds / Grundfliesen

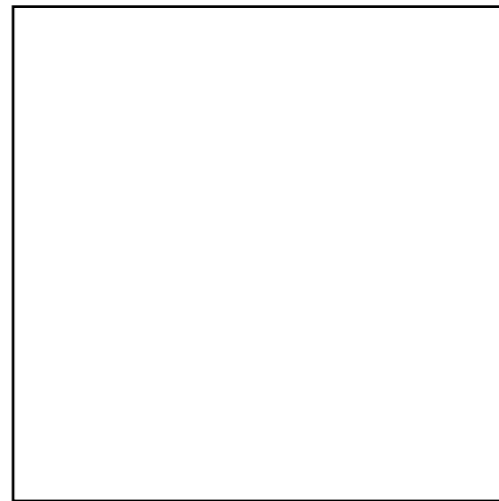

Cementi 62x62 Naturale	4
302549/31 Beige	13
302550/31 Sand	13
302551/31 Taupe	13
302552/34 Mud	61
302553/31 White	13
302554/31 Grey	13
302555/34 Fog	61
302556/34 Black	61
Cementi 60x60 Rettificato	4
302557/40 Beige	78
302558/40 Sand	78
302559/40 Taupe	78
302560/43 Mud	102
302561/40 White	78
302562/40 Grey	78
302563/43 Fog	102
302564/43 Black	102

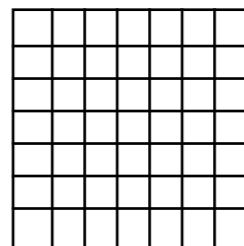

Cementi Mosaico 5x5 su rete 30x30	12
302631/117 Beige	104
302632/117 Sand	104
302633/117 Taupe	104
302636/120 Mud	105
302629/117 White	104
302630/117 Grey	104
302634/120 Fog	105
302635/120 Black	105

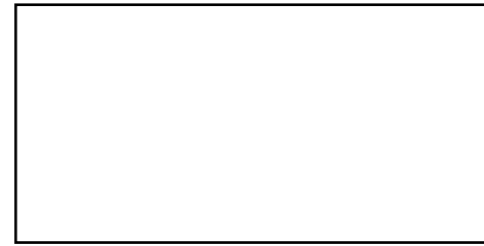

Cementi 30x60 Rettificato	6
302597/47 Beige	112
302598/47 Sand	112
302599/47 Taupe	112
302600/50 Mud	80
302601/47 White	112
302602/47 Grey	112
302603/50 Fog	80
302604/50 Black	80

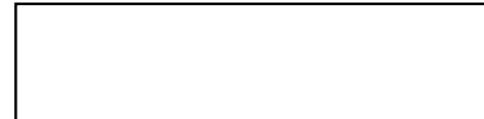

Cementi 15x60 Rettificato	14
302605/50 Beige	80
302606/50 Sand	80
302607/50 Taupe	80
302608/53 Mud	106
302609/50 White	80
302610/50 Grey	80
302611/53 Fog	106
302612/53 Black	106

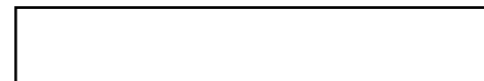

Cementi 10x60 Rettificato	15
302613/61 Beige	95
302614/61 Sand	95
302615/61 Taupe	95
302616/64 Mud	98
302617/61 White	95
302618/61 Grey	95
302619/64 Fog	98
302620/64 Black	98

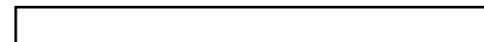

Cementi 5x60 Rettificato	30
302621/70 Beige	113
302622/70 Sand	113
302623/70 Taupe	113
302624/73 Mud	103
302625/70 White	113
302626/70 Grey	113
302627/73 Fog	103
302628/73 Black	103

Accessori / Accessories / Accessoires / Zubehörteile

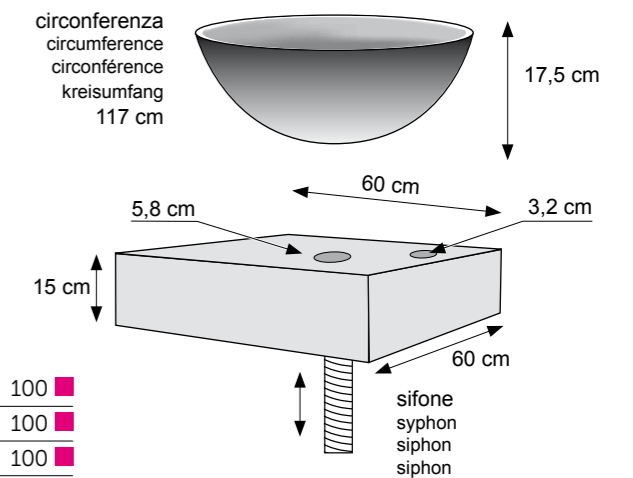

001230/1920 Set Lavabo Cementi Beige	100
001223/1920 Set Lavabo Cementi Sand	100
001224/1920 Set Lavabo Cementi Taupe	100
001225/1920 Set Lavabo Cementi Mud	100
001226/1920 Set Lavabo Cementi White	100
001227/1920 Set Lavabo Cementi Grey	100
001228/1920 Set Lavabo Cementi Fog	100
001229/1920 Set Lavabo Cementi Black	100

Lavabo, piano e rubinetteria
Wash basin, wash basin base, water tap
Lavabo, plan et robinetterie
Waschbecken, Oberfläche und Armaturen

Cementi 42,5x85 Naturale	3
302565/40 Beige	78
302566/40 Sand	78
302567/40 Taupe	78
302568/43 Mud	102
302569/40 White	78
302570/40 Grey	78
302571/43 Fog	102
302572/43 Black	102

Cementi 41,5x83 Rettificato	3
302573/51 Beige	92
302574/51 Sand	92
302575/51 Taupe	92
302576/55 Mud	97
302577/51 White	92
302578/51 Grey	92
302579/55 Fog	97
302580/55 Black	97

Pezzi speciali / Special trims / Pièces spéciales / Spezielle Teile

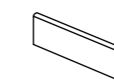

Battiscopa 7,2x62	20
...../07 Naturale	23

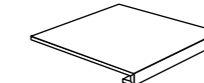

Gradino Frontale 62x62	1
...../94 Naturale	84

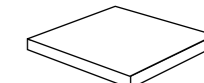

Gradino Angolare 62x62	1
...../157 Naturale	68

Battiscopa 7x60	20
...../09 Rettificato	26

Gradino Frontale 60x60	1
...../113 Rettificato	71

Gradino Angolare 60x60	1
...../186 Rettificato	73

pesi e misure / weight and sizes / poids et mesures / Gewichte und Verpackungen	spessore thickness épaisseur stärke	pz/collo pcs/box pc/boite stk/ktn	mq/collo sqm/box m/boite qm/ktn	kg/collo kg/box kg/boite kg/ktn	colli/europal box/europal boites/europal ktn/europal	mq/europal sqm/europal m/europal qm/europal	kg/europal kg/europal kg/europal kg/europal
Fondo 62x62 Nat.	9,5 mm	5	1,922	36,20	24	46,128	890
Fondo 60x60 Rett.	9,5 mm	5	1,800	33,90	24	43,20	835
Fondo 30x60 Rett.	9,5 mm	7	1,260	26,25	40	50,40	1120
Fondo 15x60 Rett.	9,5 mm	14	1,260	27,09	40	50,40	1109
Fondo 10x60 Rett.	9,5 mm	16	0,960	20,64	50	48,00	1057
Fondo 5x60 Rett.	9,5 mm	32	0,960	20,64	50	48,00	1057
Fondo 42,5x85 Nat.	10 mm	4	1,445	28,40	48	69,36	1385
Fondo 41,5x83	10 mm	4	1,378	27,08	42	57,88	1160
Mosaico 5x5 su rete 30x30	9,5 mm	12	1,0800	23,22	63	68,04	1487
Battiscopa 7,2x62	9 mm	20	12,40 ml/collo	17,00			
Battiscopa 7x60	9 mm	20	12,40 ml/collo	17,00			

Decori / Decorations / Décorations / Dekors



302773/32 66 ■
 Lambada Mix Sand
 20x33,3 18



302772/32 66 ■
 Lambada Mix Grey
 20x33,3 18



001220/40 78 ■
 Vogue Arancio
 30x60 4



001221/40 78 ■
 Vogue Lilla
 30x60 4

201653/55 97 ■
 Profilo in Alluminio anodizzato lucido
 1,2x1,2x200 10

201389/16 51 ■
 Bacchetta Diamante Oro
 1,5x60 12

201387/16 51 ■
 Bacchetta Diamante Argento
 1,5x60 12

201652/40 15 ■
 Profilo in Alluminio anodizzato satinato
 1,2x1,2x200 10

201390/16 51 ■
 Bacchetta Diamante Bronzo
 1,5x60 12

201388/16 51 ■
 Bacchetta Diamante Lilla
 1,5x60 12



note / notes / notes / anmerkungen

PROFILO IN ALLUMINIO idoneo ad ospitare il lato della piastrella sagomata con la funzione di coprifilo per l'unione di 2 formati diversi tra loro
 Aluminium section suitable for containing the edge of the shaped tile, acting as a cover for joining two different tile sizes / PROFILÉ EN ALUMINIUM pouvant recevoir le côté profilé du carreau, avec fonction de baguette pour la jonction de 2 formats différents / ALUMINIUMPROFIL, in das die Seitenkante der geformten Fliese eingefügt werden kann und das als Kantenschutz für die Verbindung von 2 untereinander verschiedenen Formaten dient.



000925/186 la Comp. 73 ■
 Comp. Cromatica
 14 listelli (6,5x20)





TT0961 Espositore serie Cementi
 cm 62x115 1
 Pannelli cm 62x83 e Pannelli cm 49x87 12



TTE240 Pannello mix&match
 cm 62x95

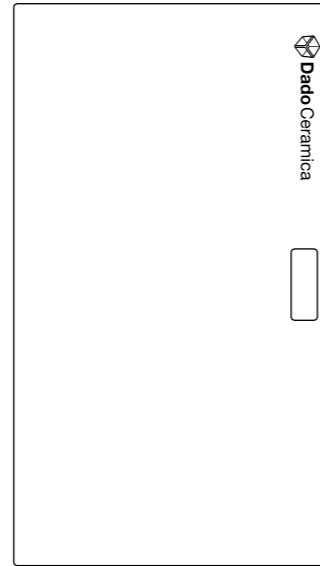

Faesite serie Cementi
 cm 49x87



TT0962 Tozzettario serie Cementi
 cm 80x33 aperto - cm 25x33 chiuso

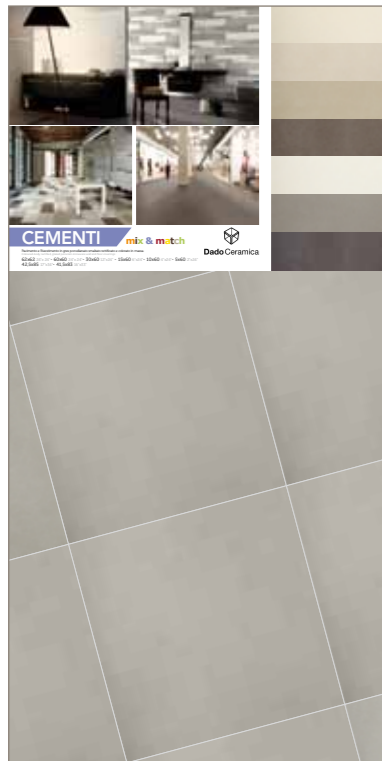

TTP078 Pannello Sinottico serie Cementi
 cm 100x200

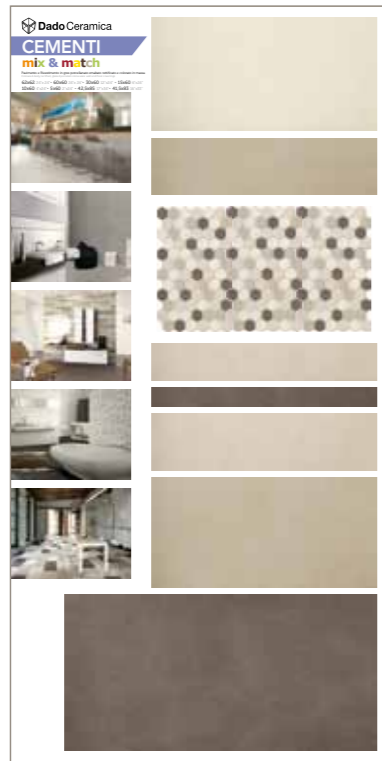

TTP079 Pannello Sinottico serie Cementi
 cm 100x200

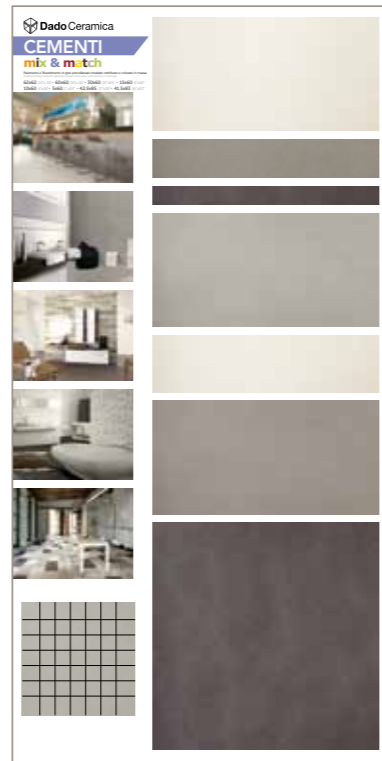

TTP080 Pannello Sinottico serie Cementi
 cm 100x200



Prodotto con leggera variazione cromatica.
 Light to moderate shade / Produit à légère variation chromatique / Produkt mit leichter Farbnuance.

loft

Pavimento e Rivestimento in gres porcellanato smaltato rettificato e colorato in massa
 Coloured-body rectified, glazed porcelain stoneware wall and floor coverings
 Revêtement et sol en grès cérame émaillé rectifié pleine masse
 Verkleidung und Fußboden aus glasiertem, geschliffenem, Gefärbte Masse Feinsteinzeug

30x60 - 60x60 - 62x62 - 42,5x85 - 41,5x83
12"x24" - 24"x24" - 24"x24" - 17"x34" - 16"x33"



Colori / Colour / Couleurs / Farben

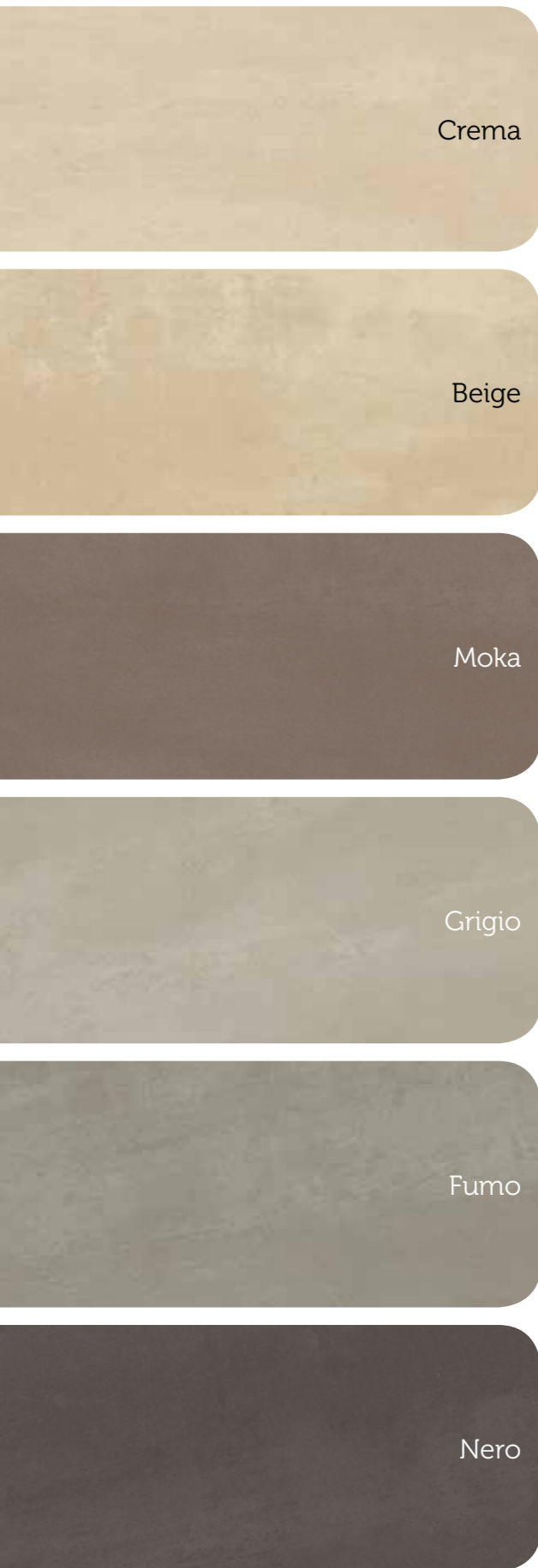

Fondi / Base tiles / Fonds / Grundfliesen

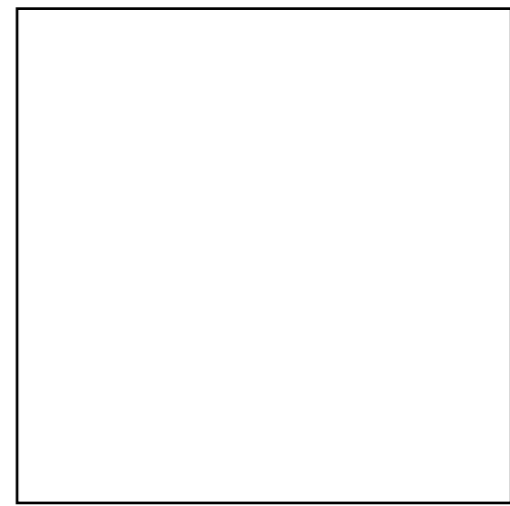

Loft 62x62 Naturale	4
302720/31 Crema	13
302721/31 Beige	13
302717/31 Moka	13
302716/31 Grigio	13
302719/31 Fumo	13
302718/31 Nero	13
Loft 60x60 Rettificato	4
302726/40 Crema	78
302729/40 Beige	78
302728/40 Moka	78
302731/40 Grigio	78
302730/40 Fumo	78
302727/40 Nero	78



Loft 30x60 Rettificato	6
302732/47 Crema	112
302733/47 Beige	112
302734/47 Moka	112

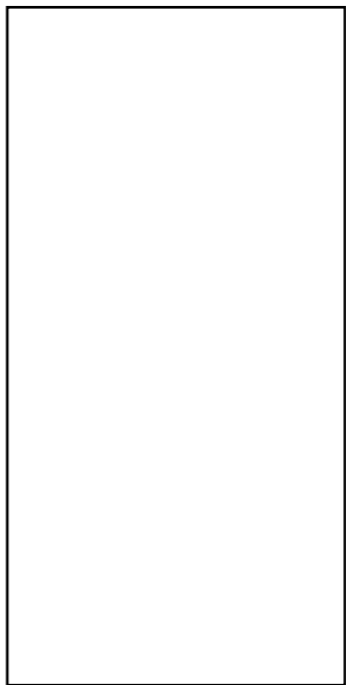

Loft 42,5x85 Naturale	3
302771/40 Crema	78
302765/40 Beige	78
302769/40 Moka	78
302768/43 Grigio	102
302767/40 Fumo	78
302770/40 Nero	78
Loft 41,5x83 Rettificato	3
302783/51 Crema	92
302778/51 Beige	92
302781/51 Moka	92
302780/55 Grigio	97
302779/51 Fumo	92
302782/51 Nero	92

Loft 30x60 Rettificato	6
302735/47 Grigio	112
302736/47 Fumo	112
302737/47 Nero	112

Pezzi speciali / Special trims / Pièces spéciales / Spezielle Teile

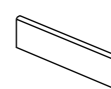

Battiscopa 7,2x62	20
...../07 Naturale	23
Battiscopa 7x60	20
...../09 Rettificato	26

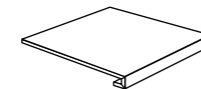

Gradino Frontale 62x62	1
...../94 Naturale	84
Gradino Frontale 60x60	1
...../113 Rettificato	71

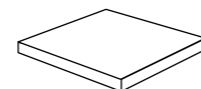

Gradino Angolare 62x62	1
...../157 Naturale	68
Gradino Angolare 60x60	1
...../186 Rettificato	73

Decori / Decorations / Décorations / Dekors



201389/16	51
Bacchetta Diamante Oro	12
1,5x60	
201390/16	51
Bacchetta Diamante Bronzo	12
1,5x60	
201387/16	51
Bacchetta Diamante Argento	12
1,5x60	
201388/16	51
Bacchetta Diamante Lilla	12
1,5x60	
R02359/12	35
Bacchetta Tribeca	10
2,1x60	



302773/32	66
Lambada Mix Sand	18
20x33,3	



302772/32	66
Lambada Mix Grey	18
20x33,3	

201653/55	97
Profilo in Alluminio anodizzato lucido	10
1,2x1,2x200	

201652/40	15
Profilo in Alluminio anodizzato satinato	10
1,2x1,2x200	

note / notes
notes / anmerkungen

PROFILO IN ALLUMINIO idoneo ad ospitare il lato della piastrela sagomata con la funzione di coprilo per l'unione di 2 formati diversi tra loro
Aluminium section suitable for containing the edge of the shaped tile, acting as a cover for joining two different tile sizes / PROFILÉ EN ALUMINIUM pouvant recevoir le côté profilé du carreau, avec fonction de baguette pour la jonction de 2 formats différents / ALUMINIUMPROFIL, in das die Seitenkante der geformten Fliese eingefügt werden kann und das als Kantenschutz für die Verbindung von 2 untereinander verschiedenen Formaten dient.

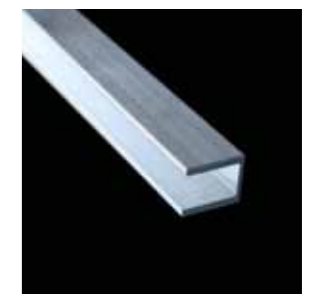

000925/186 la Comp. 73

Comp. Cromatica

14 listelli (6,5x20)

Accessori / Accessories / Accessoires / Zubehörteile

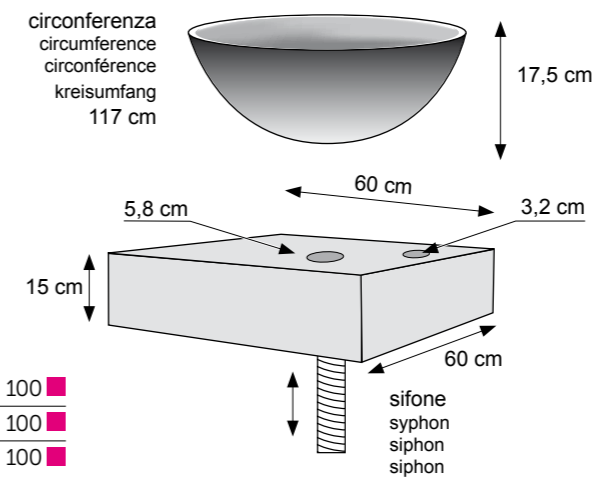

001231/1920 Set Lavabo Loft Crema	100
001232/1920 Set Lavabo Loft Beige	100
001233/1920 Set Lavabo Loft Moka	100
001234/1920 Set Lavabo Loft Grigio	100
001235/1920 Set Lavabo Loft Fumo	100
001236/1920 Set Lavabo Loft Nero	100

Lavabo, piano e rubinetteria
Wash basin, wash basin base, water tap
Lavabo, plan et robinetterie
Waschbecken, Oberfläche und Armaturen



pesi e misure / weight and sizes / poids et mesures / Gewichte und Verpackungen

dimensioni sizes dimensions abmessungen	spessore thickness épaisseur stärke	pz/collo pcs/box pc/boite stk/ktn	mq/collo sqm/box m/boite qm/ktn	kg/collo kg/box kg/boite kg/ktn	colli/europal box/europal boites/europal qm/europal	mq/europal sqm/europal m/europal qm/europal	kg/europal kg/europal kg/europal kg/europal
Fondo 62x62 Nat.	9,5 mm	5	1,922	36,20	24	46,128	890
Fondo 60x60 Rett.	9,5 mm	5	1,800	33,90	24	43,20	835
Fondo 30x60 Rett.	9,5 mm	7	1,260	26,25	40	50,40	1120
Fondo 42,5x85 Nat.	10 mm	4	1,445	28,40	48	69,36	1385
Fondo 41,5x83	10 mm	4	1,378	27,08	42	57,88	1160
Battiscopa 7,2x62	9 mm	20	12,40 ml/collo	17,00			
Battiscopa 7x60	9 mm	20	12,40 ml/collo	17,00			



TT0964 Espositore serie Loft

cm 62x115

1

Pannelli cm 62x83 e Pannelli cm 49x87

12

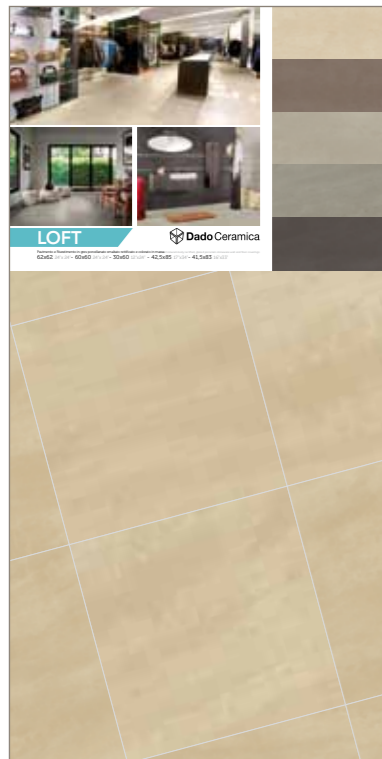

TTP081 Pannello Sinottico serie Loft

cm 100x200



Faesite serie Loft

cm 62x95

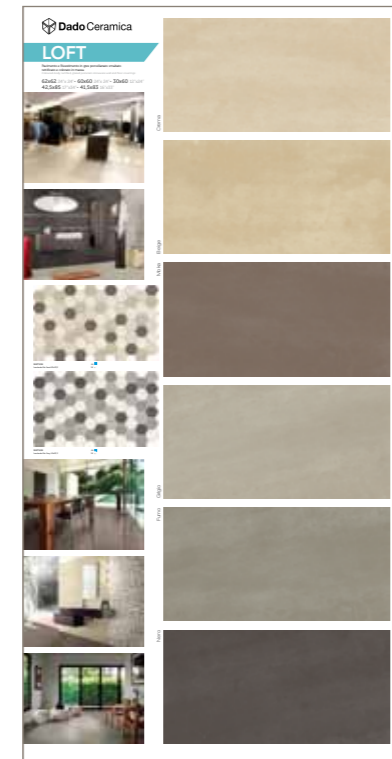

TTP082 Pannello Sinottico serie Loft

cm 100x200

merchandising

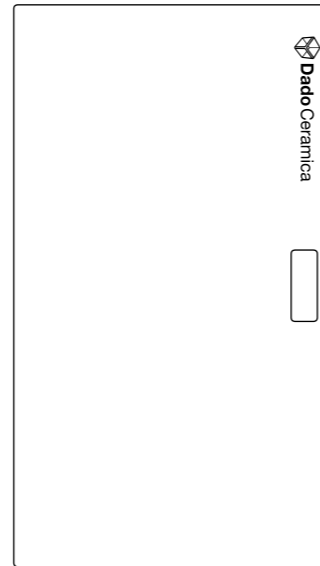

Faesite serie Loft

cm 49x87



TT0963 Tozzettario serie Loft

cm 80x33 aperto - cm 25x33 chiuso

digital technology **fullHD**

V2

Prodotto con leggera variazione cromatica.
Light to moderate shade / Produit à légère variation
chromatique / Produkt mit leichter Farbnuance.

marmi nobili

Gres porcellanato smaltato naturale e gres porcellanato smaltato lappato antiacido e antimacchia

Natural porcelain stoneware and acid-resistant, stain-resistant, lapped, glazed porcelain stoneware
Grès cérame naturel et grès cérame émaillé, rodé, anti-acide et anti-tache

Natürliches Feinsteinzeug und glasiertes, geläpptes, säure- und fleckenbeständiges Feinsteinzeug

30x30 - 31x62 - 30x60 - 44,25x44,25 - 45x45 - 40x80 - 42,5x85 - 60x60 - 62x62 - 12"x12" - 12"x24" - 12"x24" - 17"x17" - 17"x17" - 16"x31,5" - 16,7"x33" - 24"x24" - 24,5"x24,5"

Rivestimento in bicottura

Double-fired wall tiles
Revêtement biccuisson
Zweibrandverfahren Wandfliese

20x40
8"x16"



Rosa Portogallo



Crema Marfil



Bianco Carrara



Breccia Beige



Biancone



Rosa Perlino



Calacatta





Marmo Latte

Breccia Grigio

Rosa Portogallo



302436/31 PEI IV 13
Rosa Portogallo Naturale
62x62 5

302541/62 PEI V 99
Rosa Portogallo Rett. Lapp.
60x60 5



301338/27 PEI IV 07
Rosa Portogallo Naturale
31x62 7

301349/55 PEI III 97
Rosa Portogallo Rett. Lapp.
30x60 7



001131/40 78
Mosaico Righe Rosa Portogallo
30x60 (su rete) 4

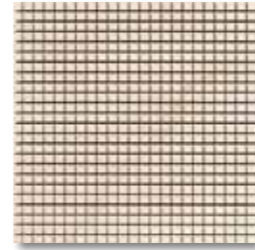

001123/26 06
Mosaico 1x1 Rosa Portogallo
29,6x28,5 (su rete) 6

201477/03 16
Tozzetto Star Brown
7x7 12



302434/40 PEI IV 78
Rosa Portogallo Naturale
42,5x85 4

302537/70 PEI V 101
Rosa Portogallo Rett. Lapp.
40x80 4



301401/27 PEI IV 07
Rosa Portogallo Naturale
45x45 7

301408/55 PEI III 97
Rosa Portogallo Rett. Lapp.
44,25x44,25 7



301373/57 PEI III 94
Rosa Portogallo Rett. Lapp.
30x30 14

301461/70 PEI V 101
Rosa Portogallo Rett. Lapp. Dur.
44,25x44,25 7

note / notes / notes / anmerkungen **Fuga consigliata vedi pag. 63** / Recommended joint size - see page 63 / Joint conseillé voir page 63 / Empfohlene Fugenmaße siehe S. 63

pesi e misure / weight and sizes / poids et mesures / Gewichte und Verpackungen

dimensioni sizes dimensions abmessungen	spessore thickness épaisseur stärke	pz/collo pcs/box pc/boite stk/ktn	mq/collo sqm/box m/boite qm/ktn	kg/collo kg/box kg/boite kg/ktn	colli/europal box/europal boites/europal ktn/europal	mq/europal sqm/europal m/europal qm/europal	kg/europal kg/europal kg/europal kg/europal
Fondo 31x62 Naturale	9 mm	7	1,35	22,00	60	81	1340
Fondo 30x60 Rett. Lapp.	9 mm	7	1,26	22,30	60	75,60	1363
Pavimento 30x30 Rett. Lapp.	9 mm	14	1,26	20,40	60	75,60	1250
Pavimento 45x45 Naturale	9 mm	7	1,4175	25,50	52	73,71	1345
Pavimento 44,25x44,25 Rett. Lapp.	9 mm	7	1,371	25,00	52	71,29	1320
Pavimento 44,25x44,25 Rett. Lapp. Dur.	9 mm	7	1,371	25,00	52	71,29	1320
Fondo 42,5x85 Naturale	10 mm	4	1,445	28,40	42	60,69	1210
Fondo 40x80 Rett. Lapp.	10 mm	4	1,28	27,52	42	53,76	1180
Pavimento 62x62 Naturale	9,5 mm	5	1,922	36,20	24	46,128	890
Fondo 60x60 Rett. Lapp.	9,5 mm	5	1,800	33,90	24	43,20	835



001103/16 51
Rosa Portogallo 30x60
Rett. Lapp. Taglio 5x5
4

201451/19 44
Toz. Greca Rosa Portogallo
5x5 4

201464/23 48
Greca Rosa Portogallo
4,5x30 12

201623/37 54
Listello Boheme Rosa Portogallo
7x40 5



201627/50 80
Provenzale Rosa Portogallo
34,5x40 4



001120/48 56
Kashmir Rosa Portogallo
30x60 12

201474/20 45
Fascia Kashmir Rosa Portogallo
11x30 6



201630/73 103
Fascia Boheme Rosa Portogallo
20x80 4



201472/16 51
Bacchetta Aurelia
3x60 12

800171/16 60
Raccordo Jolly Rosa Portogallo 1,5x30
12

800167/15 39
Tor. London Rosa Portogallo
5,5x30 4

800168/31 13
Battistraccio Rosa Portogallo
15x30 4

801017/19 53
Tor. London Rosa Portogallo
5,5x40 4

801016/26 65
Battistraccio con sguscia Rosa Portogallo
15x40 4



001105/70 89
Mosaico Topkapy
30x60 4

800172/18 40
Spig. Est. London
5,5x2 4

800207/22 42
Spigolo Est. Battistraccio
15x2 4

801034/18 40
Spig. Est. London
5,5x2 4

801036/22 42
Spigolo Est. Battistraccio
15x2 4



201478/16 51
Bacchetta Alluminium
1,5x60 15

800173/18 40
Ang. Int. London
5,5x2 4

800208/22 42
Ang. Int. Battistraccio
15x2 4

801035/18 40
Ang. Int. London
5,5x2 4

801037/22 42
Ang. Int. Battistraccio
15x2 4

Crema Marfil



302432/31 PEI IV 13
Crema Marfil Naturale
62x62 5

302542/62 PEI V 99
Crema Marfil Rett. Lapp.
60x60 5



301340/27 PEI IV 07
Crema Marfil Naturale
31x62 7

301342/55 PEI III 97
Crema Marfil Rett. Lapp.
30x60 7



001133/40 78
Mosaico Righe
Crema Marfil
30x60 (su rete) 4

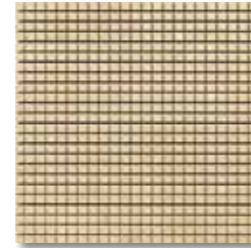

001121/26 06
Mosaico 1x1 Crema Marfil
29,6x28,5 (su rete) 6

201477/03 16
Tozzetto Star Brown
7x7 12

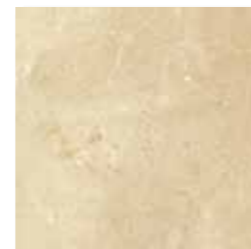

301357/57 PEI III 94
Crema Marfil Rett. Lapp.
30x30 14



302430/40 PEI IV 78
Crema Marfil Naturale
42,5x85 4

302538/70 PEI V 101
Crema Marfil Rett. Lapp.
40x80 4



301398/27 PEI IV 07
Crema Marfil Naturale
45x45 7

301405/55 PEI III 97
Crema Marfil Rett. Lapp.
44,25x44,25 7

301465/70 PEI V 101
Crema Marfil Rett. Lapp. Dur.
44,25x44,25 7

note / notes / notes / anmerkungen / Fuga consigliata vedi pag. 63 / Recommended joint size - see page 63 / Joint conseillé voir page 63 / Empfohlene Fugenmaße siehe S. 63

pesi e misure / weight and sizes / poids et mesures / Gewichte und Verpackungen

dimensioni sizes dimensions abmessungen	spessore thickness épaisseur stärke	pz/collo pc/boite stk/ctn	mq/collo sqm/box m/boite qm/ctn	kg/collo kg/box kg/boite kg/ctn	colli/euopal box/euopal boites/euopal ktn/euopal	mq/euopal sqm/euopal m/euopal qm/euopal	kg/euopal kg/euopal kg/euopal kg/euopal
Fondo 31x62 Naturale	9 mm	7	1,35	22,00	60	81	1340
Fondo 30x60 Rett. Lapp.	9 mm	7	1,26	22,30	60	75,60	1363
Pavimento 30x30 Rett. Lapp.	9 mm	14	1,26	20,40	60	75,60	1250
Pavimento 45x45 Naturale	9 mm	7	1,4175	25,50	52	73,71	1345
Pavimento 44,25x44,25 Rett. Lapp.	9 mm	7	1,371	25,00	52	71,29	1320
Pavimento 44,25x44,25 Rett. Lapp. Dur.	9 mm	7	1,371	25,00	52	71,29	1320
Fondo 42,5x85 Naturale	10 mm	4	1,445	28,40	42	60,69	1210
Fondo 40x80 Rett. Lapp.	10 mm	4	1,28	27,52	42	53,76	1180
Pavimento 62x62 Naturale	9,5 mm	5	1,922	36,20	24	46,128	890
Fondo 60x60 Rett. Lapp.	9,5 mm	5	1,800	33,90	24	43,20	835



001113/37 54
Bristol Crema Marfil
30x60 4



001112/40 15
Florenzia Crema Marfil
30x60 4



201472/16 51
Bacchetta Aurelia
3x60 12



001105/70 89
Mosaico Topkapy
30x60 4



201478/16 51
Bacchetta Alluminium
1,5x60 15



001101/70 89
Amelie Crema Marfil
30x30 2

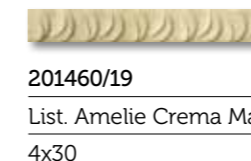

201460/19 44
List. Amelie Crema Marfil
4x30 10



201488/13 37
Listello Princess
5,5x30 6



800176/16 60
Raccordo Jolly Crema Marfil 1,5x30 12



800174/15 39
Tor. London Crema Marfil
5,5x30 4



800177/18 40
Spig. Est. London
5,5x2 4



800178/18 40
Ang. Int. London
5,5x2 4



201622/37 54
Listello Boheme Crema Marfil
7x40 5

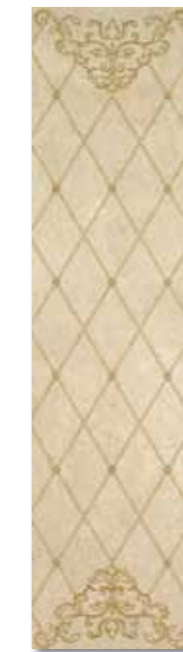

201631/73 103
Fascia Boheme Crema Marfil
20x80 4



201628/50 80
Provenzale Crema Marfil
34,5x40 4



800175/31 13
Battistraccio Crema Marfil
15x30 4



800209/22 42
Spigolo Est. Battistraccio
15x2 4



800210/22 42
Ang. Int. Battistraccio
15x2 4



801015/19 53
Tor. London Crema Marfil
5,5x40 4



801038/18 40
Spigolo Est. London
5,5x2 4



801039/18 40
Ang. Int. London
5,5x2 4



801014/26 65
Battistraccio con sguscia Crema Marfil
15x40 4



801040/22 42
Spigolo Est. Battistraccio
15x2 4



801041/22 42
Angolo Int. Battistraccio
15x2 4

Bianco Carrara



302424/31 PEI IV 13 ■
Bianco Carrara Naturale
62x62 5

302540/62 PEI V 99 ■
Bianco Carrara Rett. Lapp.
60x60 5



301339/27 PEI IV 07 ■
Bianco Carrara Naturale
31x62 7

301352/55 PEI III 97 ■
Bianco Carrara Rett. Pat.
30x60 7



001132/40 78 ■
Mosaico Righe
Bianco Carrara
30x60 (su rete) 4

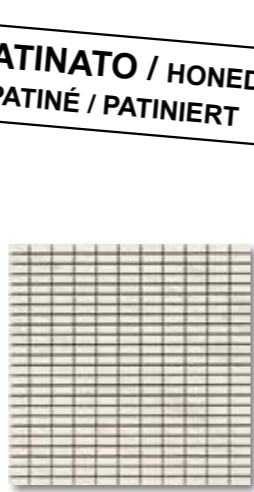

001124/25 05 ■
Mosaico Brick
Bianco Carrara
29,6x27,2 (su rete) 6

**PATINATO / HONED
PATINÉ / PATINIERT**



302422/40 PEI IV 78 ■
Bianco Carrara Naturale
42,5x85 4

302536/70 PEI V 101 ■
Bianco Carrara Rett. Lapp.
40x80 4



301395/27 PEI IV 07 ■
Bianco Carrara Naturale
45x45 7

301402/55 PEI III 97 ■
Bianco Carrara Rett. Pat.
44,25x44,25 7



201476/03 16 ■
Tozzetto Star Black
7x7 12

301377/57 PEI III 94 ■
Bianco Carrara Rett. Pat.
30x30 14

301467/70 PEI V 101 ■
Bianco Carrara Rett. Dur.
44,25x44,25 7

note / notes / notes / anmerkungen **Fuga consigliata vedi pag. 63** / Recommended joint size - see page 63 / Joint conseillé voir page 63 / Empfohlene Fugenmaße siehe S. 63

pesi e misure / weight and sizes / poids et mesures / Gewichte und Verpackungen							
dimensioni sizes dimensions abmessungen	spessore thickness épaisseur stärke	pz/collo pcs/box pc/boite stk/ktn	mq/collo sqm/box m/boite qm/ktn	kg/collo kg/box kg/boite kg/ktn	colli/europal box/europal boites/europal ktn/europal	mq/europal sqm/europal m/europal qm/europal	kg/europal kg/europal kg/europal kg/europal
Fondo 31x62 Naturale	9 mm	7	1,35	22,00	60	81	1340
Fondo 30x60 Rett. Lapp.	9 mm	7	1,26	22,30	60	75,60	1363
Pavimento 30x30 Rett. Lapp.	9 mm	14	1,26	20,40	60	75,60	1250
Pavimento 45x45 Naturale	9 mm	7	1,4175	25,50	52	73,71	1345
Pavimento 44,25x44,25 Rett. Lapp.	9 mm	7	1,371	25,00	52	71,29	1320
Pavimento 44,25x44,25 Rett. Lapp. Dur.	9 mm	7	1,371	25,00	52	71,29	1320
Fondo 42,5x85 Naturale	10 mm	4	1,445	28,40	42	60,69	1210
Fondo 40x80 Rett. Lapp.	10 mm	4	1,28	27,52	42	53,76	1180
Pavimento 62x62 Naturale	9,5 mm	5	1,922	36,20	24	46,128	890
Fondo 60x60 Rett. Lapp.	9,5 mm	5	1,800	33,90	24	43,20	835



001116/37 54 ■
Chantal Bianco Carrara
30x60 4



201467/18 40 ■
Listello Flavia
9,5x30 12



201462/33 55 ■
Listello Luminor
3x30 12



201624/37 54 ■
Listello Bohème Bianco Carrara
7x40 5



201629/50 80 ■
Provenzale Bianco Carrara
34,5x40 4



001104/16 51 ■
Bianco Carrara 30x60
Rett. Lapp. Taglio 5x5
4

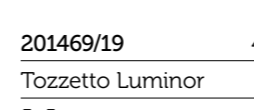

201469/19 44 ■
Tozzetto Luminor
5x5 4

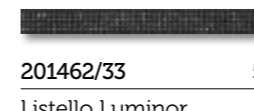

201462/33 55 ■
Listello Luminor
3x30 12



201633/73 103 ■
Fascia Bohème
Bianco Carrara
20x80 4



001105/70 89 ■
Mosaico Topkapy
30x60 4



800184/16 60 ■
Raccordo Jolly Bianco Carrara 1,5x30
12

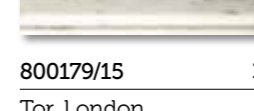

800179/15 39 ■
Tor. London
Bianco Carrara
5,5x30 4



800180/31 13 ■
Battistraccio Bianco
Carrara
15x30 4



801011/19 53 ■
Tor. London Bianco Carrara
5,5x40 4



801010/26 65 ■
Battistraccio con sguscia
Bianco Carrara
15x40 4



800182/18 40 ■
Spig. Est.
London
5,5x2 4



800185/22 42 ■
Spigolo Est.
Battistraccio
15x2 4



801030/18 40 ■
Spig. Est.
London
5,5x2 4



801032/22 42 ■
Spigolo Est.
Battistraccio
15x2 4



800183/18 40 ■
Ang. Int.
London
5,5x2 4



800186/22 42 ■
Ang. Int.
Battistraccio
15x2 4



801031/18 40 ■
Ang. Int.
London
5,5x2 4



801033/22 42 ■
Angolo Int.
Battistraccio
15x2 4

Breccia Beige



302428/31 PEI IV 13

Breccia Beige Naturale
62x62 5

302543/62 PEI V 99

Breccia Beige Rett. Lapp.
60x60 5



301457/27 PEI IV 07

Breccia Beige Naturale
31x62 7

301487/55 PEI III 97

Breccia Beige Rett. Lapp.
30x60 7



001178/40 78

Mosaico Righe Breccia Beige
30x60 (su rete) 4



001180/25 05

Mosaico Brick Breccia Beige
29,6x27,2 (su rete) 6

201477/03 16

Tozzetto Star Brown
7x7 12



302426/40 PEI IV 78

Breccia Beige Naturale
42,5x85 4

302539/70 PEI V 101

Breccia Beige Rett. Lapp.
40x80 4



301448/27 PEI IV 07

Breccia Beige Naturale
45x45 7

301451/55 PEI III 97

Breccia Beige Rett. Lapp.
44,25x44,25 7

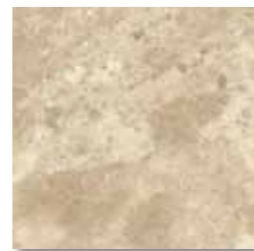

301460/57 PEI III 94

Breccia Beige Rett. Lapp.
30x30 14

301468/70 PEI V 101

Breccia Beige Rett. Lapp. Dur.
44,25x44,25 7

note / notes / notes / anmerkungen Fuga consigliata vedi pag. 63 / Recommended joint size - see page 63 / Joint conseillé voir page 63 / Empfohlene Fugenmaße siehe S. 63

pesi e misure / weight and sizes / poids et mesures / Gewichte und Verpackungen

dimensioni sizes dimensions abmessungen	spessore thickness épaisseur stärke	pz/collo pcs/box pc/boite stk/ktn	mq/collo sqm/box m/boite qm/ktn	kg/collo kg/box kg/boite kg/ktn	colli/euopal box/euopal boites/euopal ktn/euopal	mq/euopal sqm/euopal m/euopal qm/euopal	kg/euopal kg/euopal kg/euopal kg/euopal
Fondo 31x62 Naturale	9 mm	7	1,35	22,00	60	81	1340
Fondo 30x60 Rett. Lapp.	9 mm	7	1,26	22,30	60	75,60	1363
Pavimento 30x30 Rett. Lapp.	9 mm	14	1,26	20,40	60	75,60	1250
Pavimento 45x45 Naturale	9 mm	7	1,4175	25,50	52	73,71	1345
Pavimento 44,25x44,25 Rett. Lapp.	9 mm	7	1,371	25,00	52	71,29	1320
Pavimento 44,25x44,25 Rett. Lapp. Dur.	9 mm	7	1,371	25,00	52	71,29	1320
Fondo 42,5x85 Naturale	10 mm	4	1,445	28,40	42	60,69	1210
Fondo 40x80 Rett. Lapp.	10 mm	4	1,28	27,52	42	53,76	1180
Pavimento 62x62 Naturale	9,5 mm	5	1,922	36,20	24	46,128	890
Fondo 60x60 Rett. Lapp.	9,5 mm	5	1,800	33,90	24	43,20	835



201621/37 54

Listello Boheme Breccia Beige
7x40 5



201625/50 80

Provenzale Breccia Beige
34,5x40 4



201632/73 103

Fascia Boheme Breccia Beige
20x80 4



800901/15 39

Tor. London Breccia Beige
5,5x30 4



800907/31 13

Battistraccio Breccia Beige
15x30 4



801016/19 53

Tor. London Breccia Beige
5,5x40 4



801012/26 65

Battistraccio con sguscia Breccia Beige
15x40 4



800903/18 40

Spig. Est. London
5,5x2 4



800909/22 42

Spigolo Est. Battistraccio
15x2 4



801042/18 40

Spig. Est. London
5,5x2 4



801044/22 42

Spigolo Est. Battistraccio
15x2 4



800905/18 40

Ang. Int. London
5,5x2 4



800911/22 42

Ang. Int. Battistraccio
15x2 4



801043/18 40

Ang. Int. London
5,5x2 4



801045/22 42

Angolo Int. Battistraccio
15x2 4



201478/16 51

Bacchetta Alluminium
1,5x60 15



800899/16 60

Raccordo Jolly Breccia Beige
1,5x30 12

Rosa Perlino



301353/27 PEI IV 07

Rosa Perlino Naturale
31x62 7

301355/55 PEI III 97

Rosa Perlino Rett. Lapp.
30x60 7



001128/40 78

Mosaico Righe Rosa Perlino
30x60 (su rete) 4

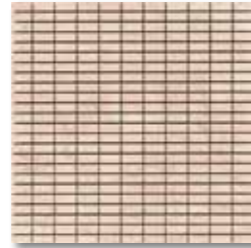

001126/25 05

Mosaico Brick Rosa Perlino
29,6x27,2 (su rete) 6



301400/27 PEI IV 07

Rosa Perlino Naturale
45x45 7

301407/55 PEI III 97

Rosa Perlino Rett. Lapp.
44,25x44,25 7



201487/03 16

Tozzetto Rosa Perlino
7x7 12



201486/03 16

Tozzetto Biancone
7x7 12



301376/57 PEI III 94

Rosa Perlino Rett. Lapp.
30x30 14

301462/70 PEI V 101

Rosa Perlino Rett. Lapp. Dur.
44,25x44,25 7

note / notes / notes / anmerkungen

Fuga consigliata almeno 2 mm per rettificati e 3 mm per naturale

We also recommend a 2 mm joint when fixing rectified tiles and a 3 mm joint when fixing non rectified tiles / Il est conseillé de garder un joint d'au moins 2 mm entre deux carreaux pour les produits rectifiés et de 3 mm pour les produits bruts / Es ist ratsam, bei den geschliffenen Fliesen eine Fuge von mindestens 2 mm zwischen den Fliese zu belassen, bei naturbelassenen, ungeschliffenen Fliesen wird eine Fugenbreite von 3 mm empfohlen.

pesi e misure / weight and sizes / poids et mesures / Gewichte und Verpackungen

dimensioni sizes dimensions abmessungen	spessore thickness épaisseur stärke	pz/collo pcs/box pc/boite stk/ktn	mq/collo sqm/box m/boite qm/ktn	kg/collo kg/box kg/boite kg/ktn	colli/europal box/europal boites/europal ktn/europal	mq/europal sqm/europal m/europal qm/europal	kg/europal kg/europal kg/europal kg/europal
Fondo 31x62 Naturale	9 mm	7	1,35	22,00	60	81	1340
Fondo 30x60 Rett. Lapp.	9 mm	7	1,26	22,30	60	75,60	1363
Pavimento 30x30 Rett. Lapp.	9 mm	14	1,26	20,40	60	75,60	1250
Pavimento 45x45 Naturale	9 mm	7	1,4175	25,50	52	73,71	1345
Pavimento 44,25x44,25 Rett. Lapp.	9 mm	7	1,371	25,00	52	71,29	1320
Pavimento 44,25x44,25 Rett. Lapp. Dur.	9 mm	7	1,371	25,00	52	71,29	1320



001106/33 55

Focus Rosa Perlino
30x60 4



001119/16 51

Fascia Priscilla
30x60 (su rete) 4



001105/70 89

Mosaico Topkapy
30x60 4



201478/16 51

Bacchetta Alluminium
1,5x60 15



800199/16 60

Raccordo Jolly Rosa Perlino
1,5x30 12



201473/23 48

Greca Pompea
10x30 10



800197/15 39

Tor. London Rosa Perlino
5,5x30 4



800200/18 40

Spig. Est. London
5,5x2 4



800201/18 40

Ang. Int. London
5,5x2 4



800198/31 13

Battistraccio Rosa Perlino
15x30 4



800215/22 42

Spigolo Est. Battistraccio
15x2 4



800216/22 42

Ang. Int. Battistraccio
15x2 4

Biancone

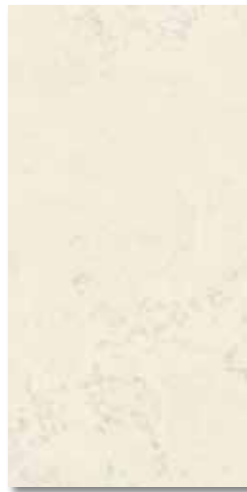

301354/27 PEI IV 07

Biancone Naturale

31x62 7

301356/55 PEI III 97

Biancone Rett. Lapp.

30x60 7



001129/40 78

Mosaico Righe Biancone

30x60 (su rete) 4

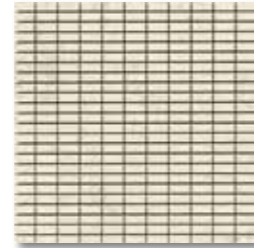

001127/25 05

Mosaico Brick Biancone

29,6x27,2 (su rete) 6



201487/03 16

Tozzetto Rosa Perlino

7x7 12



201486/03 16

Tozzetto Biancone

7x7 12

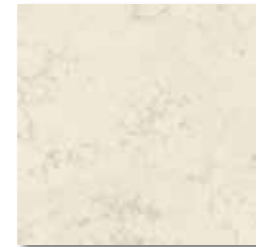

301375/57 PEI III 94

Biancone Rett. Lapp.

30x30 14

note / notes / notes / anmerkungen

Fuga consigliata almeno 2 mm per rettificati e 3 mm per naturale

We also recommend a 2 mm joint when fixing rectified tiles and a 3 mm joint when fixing non rectified tiles / Il est conseillé de garder un joint d'au moins 2 mm entre deux carreaux pour les produits rectifiés et de 3 mm pour les produits bruts / Es ist ratsam, bei den geschliffenen Fliesen eine Fuge von mindestens 2 mm zwischen den Fliese zu belassen, bei naturbelassenen, ungeschliffenen Fliesen wird eine Fugenbreite von 3 mm empfohlen.

301396/27 PEI IV 07

Biancone Naturale

45x45 7

301403/55 PEI III 97

Biancone Rett. Lapp.

44,25x44,25 7

301463/70 PEI V 101

Biancone Rett. Lapp. Dur.

44,25x44,25 7

pesi e misure / weight and sizes / poids et mesures / Gewichte und Verpackungen

dimensioni sizes dimensions abmessungen	spessore thickness épaisseur stärke	pz/collo pcs/box pc/boite stk/ktn	mq/collo sqm/box m/boite qm/ktn	kg/collo kg/box kg/boite kg/ktn	colli/europal box/europal boites/europal ktn/europal	mq/europal sqm/europal m/europal qm/europal	kg/europal kg/europal kg/europal kg/europal
Fondo 31x62 Naturale	9 mm	7	1,35	22,00	60	81	1340
Fondo 30x60 Rett. Lapp.	9 mm	7	1,26	22,30	60	75,60	1363
Pavimento 30x30 Rett. Lapp.	9 mm	14	1,26	20,40	60	75,60	1250
Pavimento 45x45 Naturale	9 mm	7	1,4175	25,50	52	73,71	1345
Pavimento 44,25x44,25 Rett. Lapp.	9 mm	7	1,371	25,00	52	71,29	1320
Pavimento 44,25x44,25 Rett. Lapp. Dur.	9 mm	7	1,371	25,00	52	71,29	1320



001176/40 15

Florenzia Biancone

30x60 4



001119/16 51

Fascia Priscilla

30x60 (su rete) 4



201472/16 51

Bacchetta Aurelia

3x60 12



001105/70 89

Mosaico Topkapy

30x60 4



201478/16 51

Bacchetta Alluminium

1,5x60 15



800194/16 60

Raccordo Jolly Biancone

1,5x30 12



201473/23 48

Greca Pompea

10x30 10



800192/15 39

Tor. London Biancone

5,5x30 4



800195/18 40

Spig. Est. London

5,5x2 4



800196/18 40

Ang. Int. London

5,5x2 4



800193/31 13

Battistraccio Biancone

15x30 4



800213/22 42

Spigolo Est. Battistraccio

15x2 4



800214/22 42

Ang. Int. Battistraccio

15x2 4

Calacatta



301347/27 PEI IV 07

Calacatta Naturale

31x62 7

301351/55 PEI III 97

Calacatta Rett. Lapp.

30x60 7



001130/40 78

Mosaico Righe Calacatta

30x60 (su rete) 4

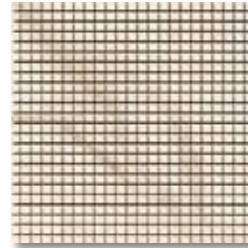

001122/26 06

Mosaico 1x1 Calacatta

29,6x28,5 (su rete) 6



301397/27 PEI IV 07

Calacatta Naturale

45x45 7

301404/55 PEI III 97

Calacatta Rett. Lapp.

44,25x44,25 7



201477/03 16

Tozzetto Star Brown

7x7 12

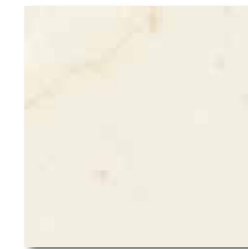

301315/57 PEI III 94

Calacatta Rett. Lapp.

30x30 14

note / notes / notes / anmerkungen

Fuga consigliata almeno 2 mm per rettificati e 3 mm per naturale

We also recommend a 2 mm joint when fixing rectified tiles and a 3 mm joint when fixing non rectified tiles / Il est conseillé de garder un joint d'au moins 2 mm entre deux carreaux pour les produits rectifiés et de 3 mm pour les produits bruts / Es ist ratsam, bei den geschliffenen Fliesen eine Fuge von mindestens 2 mm zwischen den Fliese zu belassen, bei naturbelassenen, ungeschliffenen Fliesen wird eine Fugenbreite von 3 mm empfohlen.

pesi e misure / weight and sizes / poids et mesures / Gewichte und Verpackungen

dimensioni sizes dimensions abmessungen	spessore thickness épaisseur stärke	pz/collo pcs/box pc/boite stk/ktn	mq/collo sqm/box m/boite qm/ktn	kg/collo kg/box kg/boite kg/ktn	colli/europal boxes/europal ktn/europal	mq/europal sqm/europal m/europal qm/europal	kg/europal kg/europal kg/europal kg/europal
Fondo 31x62 Naturale	9 mm	7	1,35	22,00	60	81	1340
Fondo 30x60 Rett. Lapp.	9 mm	7	1,26	22,30	60	75,60	1363
Pavimento 30x30 Rett. Lapp.	9 mm	14	1,26	20,40	60	75,60	1250
Pavimento 45x45 Naturale	9 mm	7	1,4175	25,50	52	73,71	1345
Pavimento 44,25x44,25 Rett. Lapp.	9 mm	7	1,371	25,00	52	71,29	1320
Pavimento 44,25x44,25 Rett. Lapp. Dur.	9 mm	7	1,371	25,00	52	71,29	1320



001117/37 54

Chantal Calacatta

30x60 4



001102/16 51

Calacatta 30x60 Rett. Lapp. Taglio 5x5

4



201472/16 51

Bacchetta Aurelia

3x60 12



001105/70 89

Mosaico Topkapy

30x60 4



201478/16 51

Bacchetta Alluminium

1,5x60 15



800189/16 60

Raccordo Jolly Calacatta

1,5x30 12



201463/23 48

Greca Calacatta

4,5x30 12



800187/15 39

Tor. London Calacatta

5,5x30 4

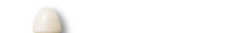

800190/18 40

Spig. Est. London

5,5x2 4



800191/18 40

Ang. Int. London

5,5x2 4



800188/31 13

Battistraccio Calacatta

15x30 4



800211/22 42

Spigolo Est. Battistraccio

15x2 4



800212/22 42

Ang. Int. Battistraccio

15x2 4

Marmo Latte



301341/27 PEI IV 07

Marmo Latte Naturale
31x62 7

301350/55 PEI III 97

Marmo Latte Rett. Lapp.
30x60 7



001134/40 78

Mosaico Righe Marmo Latte
30x60 (su rete) 4

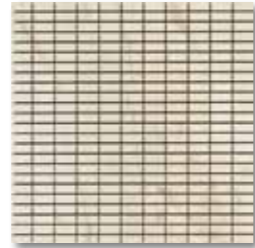

001125/25 05

Mosaico Brick Marmo Latte
29,6x27,2 (su rete) 6



301399/27 PEI IV 07

Marmo Latte Naturale
45x45 7

301406/55 PEI III 97

Marmo Latte Rett. Lapp.
44,25x44,25 7



201477/03 16

Tozzetto Star Brown
7x7 12



301374/57 PEI III 94

Marmo Latte Rett. Lapp.
30x30 14

301466/70 PEI V 101

Marmo Latte Rett. Lapp. Dur.
44,25x44,25 7

note / notes / notes / anmerkungen

Fuga consigliata almeno 2 mm per rettificati e 3 mm per naturale

We also recommend a 2 mm joint when fixing rectified tiles and a 3 mm joint when fixing non rectified tiles / Il est conseillé de garder un joint d'au moins 2 mm entre deux carreaux pour les produits rectifiés et de 3 mm pour les produits bruts / Es ist ratsam, bei den geschliffenen Fliesen eine Fuge von mindestens 2 mm zwischen den Fliese zu belassen, bei naturbelassenen, ungeschliffenen Fliesen wird eine Fugenbreite von 3 mm empfohlen.

pesi e misure / weight and sizes / poids et mesures / Gewichte und Verpackungen

dimensioni sizes dimensions abmessungen	spessore thickness épaisseur stärke	pz/collo pcs/box pc/boite stk/ktn	mq/collo sqm/box m/boite qm/ktn	kg/collo kg/box kg/boite kg/ktn	colli/europal box/europal boites/europal ktn/europal	mq/europal sqm/europal m/europal qm/europal	kg/europal kg/europal kg/europal kg/europal
Fondo 31x62 Naturale	9 mm	7	1,35	22,00	60	81	1340
Fondo 30x60 Rett. Lapp.	9 mm	7	1,26	22,30	60	75,60	1363
Pavimento 30x30 Rett. Lapp.	9 mm	14	1,26	20,40	60	75,60	1250
Pavimento 45x45 Naturale	9 mm	7	1,4175	25,50	52	73,71	1345
Pavimento 44,25x44,25 Rett. Lapp.	9 mm	7	1,371	25,00	52	71,29	1320
Pavimento 44,25x44,25 Rett. Lapp. Dur.	9 mm	7	1,371	25,00	52	71,29	1320



001118/37 54

Chantal Marmo Latte
30x60 4



201472/16 51

Bacchetta Aurelia
3x60 12



001105/70 89

Mosaico Topkapy
30x60 4



201478/16 51

Bacchetta Alluminium
1,5x60 15



800204/16 60

Raccordo Jolly Marmo Latte 1,5x30 12



800202/15 39

Tor. London Marmo Latte
5,5x30 4



800205/18 40

Spig. Est. London
5,5x2 4



800206/18 40

Ang. Int. London
5,5x2 4



001100/70 89

Amelie Marmo Latte
30x30 2



800203/31 13

Battistraccio Marmo Latte
15x30 4



800217/22 42

Spigolo Est. Battistraccio
15x2 4



800218/22 42

Ang. Int. Battistraccio
15x2 4



201461/19 44

List. Amelie Marmo Latte
4x30 10

Breccia Grigio



301458/27 PEI IV 07
Breccia Grigio Naturale
31x62 7

301488/55 PEI III 97
Breccia Grigio Rett. Lapp.
30x60 7



001177/40 78
Mosaico Righe Breccia Grigio
30x60 (su rete) 4



201476/03 16
Tozzetto Star Black
7x7 12

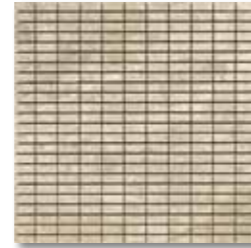

001179/25 05
Mosaico Brick Breccia Grigio
29,6x27,2 (su rete) 6

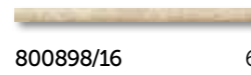

800898/16 60
Raccordo Jolly Breccia Grigio
1,5x30 12



201478/16 51
Bacchetta Alluminium
1,5x60 15



800900/15 39
Tor. London Breccia Grigio
5,5x30 4



800902/18 40
Spig. Est. London
5,5x2 4



800904/18 40
Ang. Int. London
5,5x2 4



301449/27 PEI IV 07
Breccia Grigio Naturale
45x45 7

301450/55 PEI III 97
Breccia Grigio Rett. Lapp.
44,25x44,25 7



301459/57 PEI III 94
Breccia Grigio Rett. Lapp.
30x30 14

301469/70 PEI V 101
Breccia Grigio Rett. Lapp. Dur.
44,25x44,25 7



800906/31 13
Battistraccio Breccia Grigio
15x30 4



800908/22 42
Spigolo Est. Battistraccio
15x2 4



800910/22 42
Ang. Int. Battistraccio
15x2 4

note / notes / notes / anmerkungen

Fuga consigliata vedi pag. 63
Recommended joint size - see page 63 / Joint conseillé voir page 63 / Empfohlene Fugenmaße siehe S. 63

pesi e misure / weight and sizes / poids et mesures / Gewichte und Verpackungen

dimensioni sizes dimensions abmessungen	spessore thickness épaisseur stärke	pz/collo pcs/box pc/boite stk/ktn	mq/collo sqm/box m ² /boite qm/ktn	kg/collo kg/box kg/boite kg/ktn	colli/europal box/europal boites/europal ktn/europal	mq/europal sqm/europal m ² /europal qm/europal	kg/europal kg/europal kg/europal kg/europal
Fondo 31x62 Naturale	9 mm	7	1,35	22,00	60	81	1340
Fondo 30x60 Rett. Lapp.	9 mm	7	1,26	22,30	60	75,60	1363
Pavimento 30x30 Rett. Lapp.	9 mm	14	1,26	20,40	60	75,60	1250
Pavimento 45x45 Naturale	9 mm	7	1,4175	25,50	52	73,71	1345
Pavimento 44,25x44,25 Rett. Lapp.	9 mm	7	1,371	25,00	52	71,29	1320
Pavimento 44,25x44,25 Rett. Lapp. Dur.	9 mm	7	1,371	25,00	52	71,29	1320

Decori / Decorations / Décorations / Dekors

800354/05 17
Diagonale Rovere Antico SX
7,5x44,25 28

800353/05 17
Diagonale Rovere Antico DX
7,5x44,25 28

800984/05 17
List. Rovere Antico
7,5x44,25 28

note / notes / notes / anmerkungen

Si consiglia una posa della diagonale con almeno 2 mm di fuga. Da posare solo con prodotti rettificati.
We recommend a 2 mm joint when laying the diagonal tile. To lay down only with rectified products / Il est conseillé de procéder à une pose de la diagonale avec un joint d'au moins 2 mm. A poses uniquement avec des produits rectifiés / Es wird eine Verlegung der Diagonale mit mindestens 2 mm Fugenbreite empfohlen. Nur mit rektifizierte Produkte Verlegung.

Pezzi speciali / Special trims / Pièces spéciales / Spezielle Teile

Battiscopa 8,5x45 20
800873/06 Rosa Portogallo Nat. 18
800881/06 Rosa Perlino Naturale 18
800883/06 Biancone Naturale 18
800871/06 Calacatta Naturale 18
800877/06 Crema Marfil Naturale 18
800879/06 Marmo Latte Naturale 18
800875/06 Bianco Carrara Naturale 18
800887/06 Breccia Grigio Naturale 18
800889/06 Breccia Beige Naturale 18

Battiscopa 8,5x44,25 20
800874/07 Rosa Portogallo Rett. Lapp. 22
800882/07 Rosa Perlino Rett. Lapp. 22
800884/07 Biancone Rett. Lapp. 22
800872/07 Calacatta Rett. Lapp. 22
800878/07 Crema Marfil Rett. Lapp. 22
800880/07 Marmo Latte Rett. Lapp. 22
800876/07 Bianco Carrara Rett. Pat. 22
800888/07 Breccia Grigio Rett. Lapp. 22
800890/07 Breccia Beige Rett. Lapp. 22

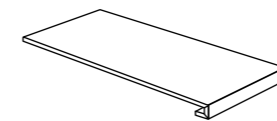

Gradino Frontale
31x62/42 1
Naturale 85

Gradino Frontale
30x60/56 1
Lappato 93

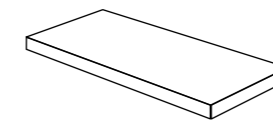

Gradino Angolare
DX 31x62/113 1
Naturale 71

Gradino Angolare
SX 31x62/113 1
Naturale 71

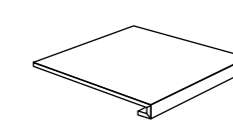

Gradino Frontale
45x45/51 1
Naturale 92

Gradino Frontale
44,25x44,25/62 1
Lappato 99

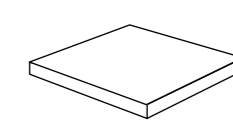

Gradino Angolare
45x45/117 1
Naturale 104

Gradino Angolare
44,25x44,25/117 1
Lappato 104

Schemi di posa / Laying patterns / Schémas de pose / Verlegungsschemen

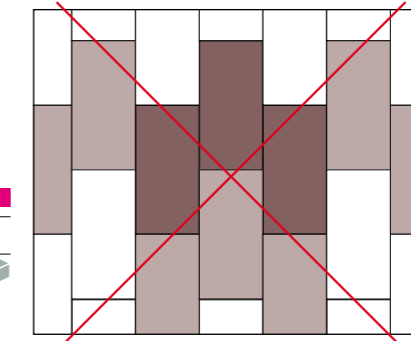

Non è consigliabile posare il materiale falsato di 1/2 (30-30,5 cm).

We do not recommend laying the material in a 1/2 (30-30,5 cm) staggered pattern.
Il est déconseillé de poser le matériau avec un décalage de 1/2 (30-30,5 cm)
Es ist nicht empfehlenswert, das Material 1/2 (30-30,5 cm) versetzt zu verlegen.

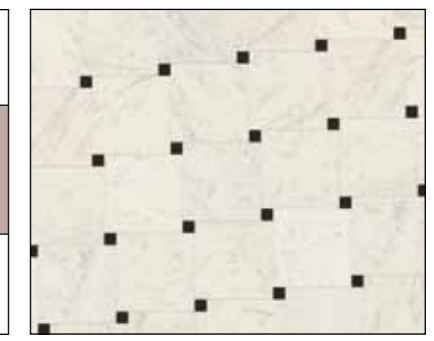

formati sizes	pz/modulo	%/mq	pz/mq
44,25x44,25	1	97,56	4,98
7x7	1	2,44	4,98
45x45	1	97,64	4,82
7x7	1	2,36	4,82



formati sizes	pz/modulo	%/mq	pz/mq
44,25x44,25	4	84,986	4,34
7,5x44,25 SX	1	3,906	1,085
7,5x44,25 DX	1	3,906	1,085
7,5x44,25	2	7,202	2,17

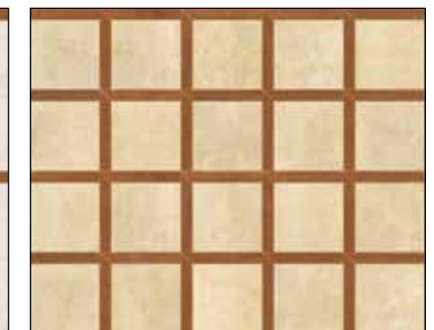

formati sizes	pz/modulo	%/mq	pz/mq
44,25x44,25	1	73,12	3,73
7,5x44,25 SX	1	13,44	3,73
7,5x44,25 DX	1	13,44	3,73

note / notes / notes / anmerkungen

Fuga consigliata almeno 2 mm per rettificati e 3 mm per naturale
We also recommend a 2 mm joint when fixing rectified tiles and a 3 mm joint when fixing non rectified tiles / Il est conseillé de garder un joint d'au moins 2 mm entre deux carreaux pour les produits rectifiés et de 3 mm pour les produits bruts / Es ist ratsam, bei den geschliffenen Fliesen eine Fuge von mindestens 2 mm zwischen den Fliese zu belassen, bei naturbelassenen, ungeschliffenen Fliesen wird eine Fugenbreite von 3 mm empfohlen.



Crema Marfil



Rosa Portogallo



Marmo Latte



Biancone

Rosa Portogallo



302528/20 45 ■
Rosa Portogallo
20x40

800171/16 60 ■
Raccordo Jolly Rosa Portogallo 1,5x30 12 ■

800167/15 39 ■ 800172/18 40 ■ 800173/18 40 ■
Tor. London Rosa Portogallo Spig. Est. London Ang. Int. London
5,5x30 4 ■ 5,5x2 4 ■ 5,5x2 4 ■

800168/31 13 ■ 800207/22 42 ■ 800208/22 42 ■
Battistraccio Rosa Portogallo Spigolo Est. Battistraccio Ang. Int. Battistraccio
15x30 4 ■ 15x2 4 ■ 15x2 4 ■

Crema Marfil



302526/20 45 ■
Crema Marfil
20x40

800176/16 60 ■
Raccordo Jolly Crema Marfil 1,5x30 12 ■

800174/15 39 ■ 800177/18 40 ■ 800178/18 40 ■
Tor. London Crema Marfil Spig. Est. London Ang. Int. London
5,5x30 4 ■ 5,5x2 4 ■ 5,5x2 4 ■

800175/31 13 ■ 800209/22 42 ■ 800210/22 42 ■
Battistraccio Crema Marfil Spigolo Est. Battistraccio Ang. Int. Battistraccio
15x30 4 ■ 15x2 4 ■ 15x2 4 ■

Biancone



302527/20 45 ■
Biancone
20x40

800194/16 60 ■
Raccordo Jolly Biancone 1,5x30 12 ■

800192/15 39 ■ 800195/18 40 ■ 800196/18 40 ■
Tor. London Biancone Spig. Est. London Ang. Int. London
5,5x30 4 ■ 5,5x2 4 ■ 5,5x2 4 ■

800193/31 13 ■ 800213/22 42 ■ 800214/22 42 ■
Battistraccio Biancone Spigolo Est. Battistraccio Ang. Int. Battistraccio
15x30 4 ■ 15x2 4 ■ 15x2 4 ■

Marmo Latte



302524/20 45 ■
Marmo Latte
20x40

800204/16 60 ■
Raccordo Jolly Marmo Latte 1,5x30 12 ■

800202/15 39 ■ 800205/18 40 ■ 800206/18 40 ■
Tor. London Marmo Latte Spig. Est. London Ang. Int. London
5,5x30 4 ■ 5,5x2 4 ■ 5,5x2 4 ■

800203/31 13 ■ 800217/22 42 ■ 800218/22 42 ■
Battistraccio Marmo Latte Spigolo Est. Battistraccio Ang. Int. Battistraccio
15x30 4 ■ 15x2 4 ■ 15x2 4 ■

Decorati / Decorations / Décorations / Dekors



302534/132 90 ■
Mosaico Marmi Grigio
20x40 13 ■

201577/06 19 ■
Listello Marmi Grigio
2,5x40 24 ■



302535/132 90 ■
Mosaico Marmi Beige
20x40 13 ■

201578/06 19 ■
Listello Marmi Beige
2,5x40 24 ■



001203/19 44 ■
Decoro Ondus
20x40 6 ■

201576/10 30 ■
Listello Ondus
2,5x40 18 ■

pesi e misure / weight and sizes / poids et mesures / Gewichte und Verpackungen

dimensioni sizes dimensions abmessungen	spessore thickness épaisseur stärke	pz/collo pcs/box pc/boite stk/ktn	mq/collo sqm/box m/boite qm/ktn	kg/collo kg/box kg/boite kg/ktn	colli/euopal box/euopal boites/euopal ktn/euopal	mq/euopal sqm/euopal m/euopal qm/euopal	kg/euopal kg/euopal kg/euopal kg/euopal
Fondo 20x40	7 mm	19	1,52	19	64	97,28	1240
Mosaico 20x40	7 mm	13	1,04	13,00			





TTP058 Pannello Sinottico serie Marmi Nobili Riassuntivo

cm 100x200



TTP048 Pannello Sinottico serie Marmi Nobili Rosa Portogallo

cm 100x200



TTP049 Pannello Sinottico serie Marmi Nobili Rosa Perlino

cm 100x200



TTP050 Pannello Sinottico serie Marmi Nobili Biancone

cm 100x200



TTP051 Pannello Sinottico serie Marmi Nobili Calacatta

cm 100x200



TTP052 Pannello Sinottico serie Marmi Nobili Crema Marfil

cm 100x200



TTP053 Pannello Sinottico serie Marmi Nobili Marmo Latte

cm 100x200



TTP054 Pannello Sinottico serie Marmi Nobili Bianco Carrara

cm 100x200



TTP055 Pannello Sinottico serie Marmi Nobili Breccia Grigio

cm 100x200



TTP056 Pannello Sinottico serie Marmi Nobili Breccia Beige

cm 100x200

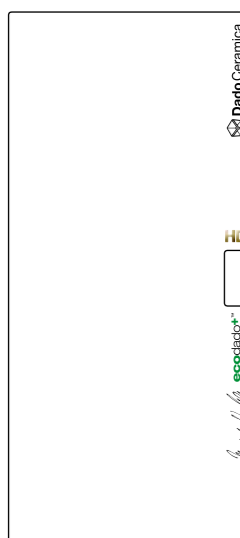

Faesite serie Marmi Nobili

cm 49x106

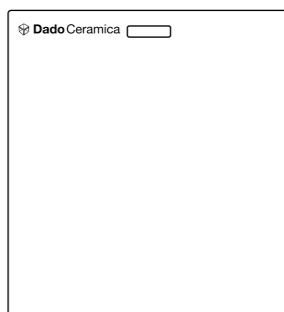

Faesite serie Marmi Nobili

cm 62x68



Prodotto con marcata variazione cromatica.
High shade texture variation within each carton.
Produit à variation chromatique accentuée.
Produkt mit ausgeprägter Farbnuance.

graniti

Rivestimento in gres porcellanato
smaltato rettificato lappato

Rectified, lapped porcelain stoneware wall tiles
Revêtement en grès cérame rectifié et poli
Verkleidung aus geläpftem rektifiziertem Feinsteinzeug

30x60
12"x24"



Colori / Colour / Couleurs / Farben



302529/47 112 ■
Granito Carrara Rett. Lapp. PEI III
30x60 7



302531/47 112 ■
Granito Grigio Rett. Lapp. PEI III
30x60 7



302533/47 112 ■
Granito Nero Rett. Lapp. PEI III
30x60 7



302530/47 112 ■
Granito Beige Rett. Lapp. PEI III
30x60 7



302532/47 112 ■
Granito Marrone Rett. Lapp. PEI III
30x60 7

pesi e misure / weight and sizes / poids et mesures / Gewichte und Verpackungen

dimensioni sizes dimensions abmessungen	spessore thickness épaisseur stärke	pz/collo pcs/box pc/boite stk/ktn	mq/collo sqm/box m/boite qm/ktn	kg/collo kg/box kg/boite kg/ktn	colli/euopal box/euopal boites/euopal ktn/euopal	mq/euopal sqm/euopal m/euopal qm/euopal	kg/euopal kg/euopal kg/euopal kg/euopal
Fondo 30x60	9 mm	7	1,26	22,30	60	75,60	1363

merchandising

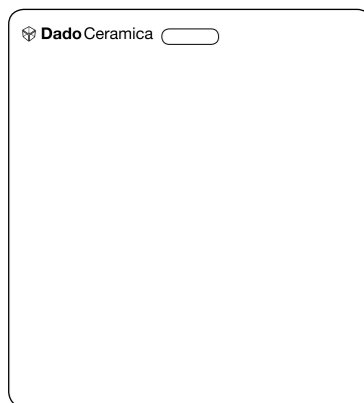

Faesite serie Graniti
cm 62x68



TTP099 Pannello Sinottico
serie Graniti
cm 100x200



Prodotto con leggera variazione cromatica.
Light to moderate shade / Produit à légère variation
chromatique / Produkt mit leichter Farbnuance.

stardust

Rivestimento e pavimento in gres porcellanato
smaltato rettificato lappato antiacido e antimacchia
Rectified, lapped, acid-resistant, stain-resistant glazed porcelain
stoneware wall and floor tiles
Revêtement et sol en grès cérame émaillé rectifié, rodé, anti-aci-
de, anti-tache
Verkleidung und Boden aus glasiertem Feinsteinzeug, geschliff.,
geläppt, säurefest, fleckenabweisend

30x60 - 15x60 - 30x30 - 33,3x33,3 - 44,25x44,25
12"x24" - 6"x24" - 12"x12" - 13"x13" - 18"x18"





White

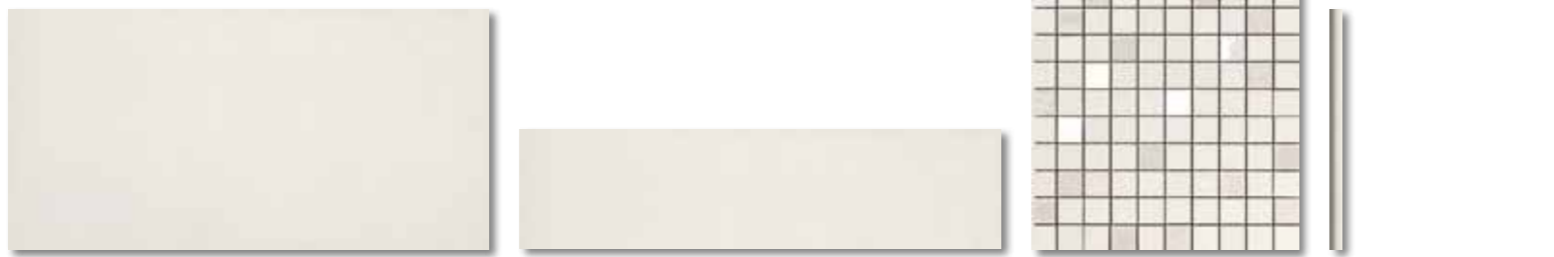

301199/55	97	301213/57	94	301240/186	73	201408/16	60
Star White Rett. Lapp.	PEI III	Star White Rett. Lapp.	PEI III	Mosaico Star White		Raccordo Star White	
30x60	7	15x60	14	33,3x33,3 (su rete)	9	1,5x30	12

Black



301198/55	97	301211/57	94	301236/186	73	201411/16	60
Star Black Rett. Lapp.	PEI III	Star Black Rett. Lapp.	PEI III	Mosaico Star Black		Raccordo Star Black	
30x60	7	15x60	14	33,3x33,3 (su rete)	9	1,5x30	12

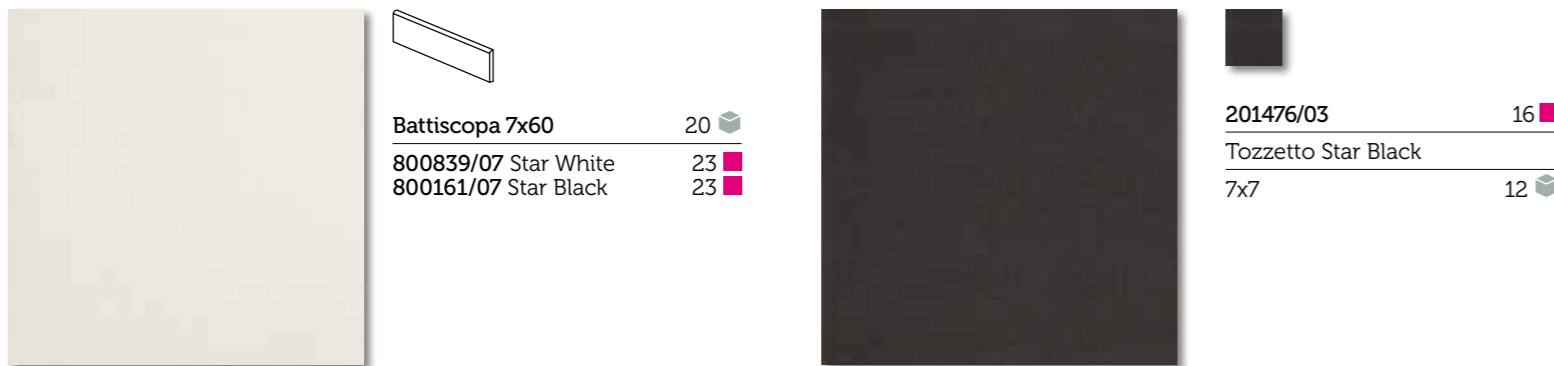

301430/55	97	301221/57	94	301431/55	97	301219/57	94
Star White Rett. Lapp.	PEI III	Star White Rett. Lapp.	PEI III	Star Black Rett. Lapp.	PEI III	Star Black Rett. Lapp.	PEI III
44,25x44,25	7	30x30	14	44,25x44,25	7	30x30	14

pesi e misure / weight and sizes / poids et mesures / Gewichte und Verpackungen							
dimensioni sizes dimensions abmessungen	spessore thickness épaisseur stärke	pz/collo pcs/box pc/boite stk/ktn	mq/collo sqm/box m/boite qm/ktn	kg/collo kg/box kg/boite kg/ktn	colli/europal box/europal boites/europal ktn/europal	mq/europal sqm/europal m/europal qm/europal	kg/europal kg/europal kg/europal kg/europal
Fondo 15x60	9	14	1,26	24,8	40	50,4	1017
Fondo 30x60	9	7	1,26	25,1	60	75,6	1531
Mosaico 33,3x33,3	9	9	1	18,0			
Fondo 30x30	9	14	1,26	24,9	60	76,5	1519
Fondo 44,25x44,25	9	7	1,3706	25,0	52	71,29	1320

Decori / Decorations / Décorations / Dekors



201377/38	49	201374/38	49	001058/15	39
Laser White		Prisma White		Modus Star White	
30x60	4	30x60	4	30x60	6

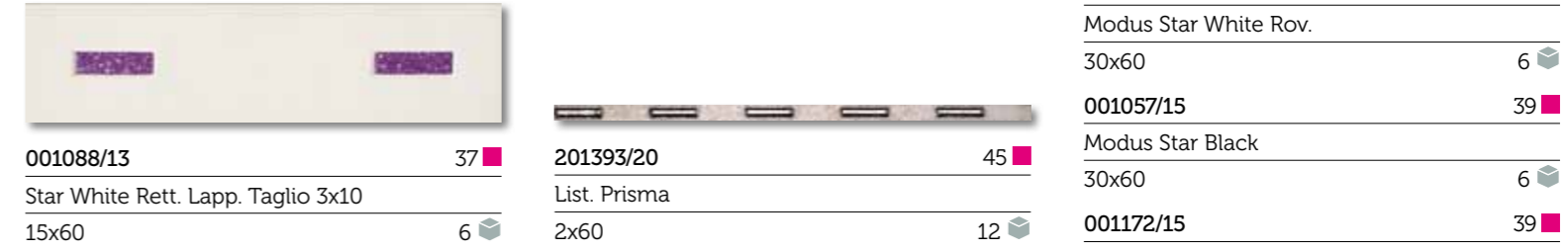

001088/13	37	201393/20	45	001174/15	39
Star White Rett. Lapp. Taglio 3x10		List. Prisma		Modus Star White Rov.	
15x60	6	2x60	12	30x60	6

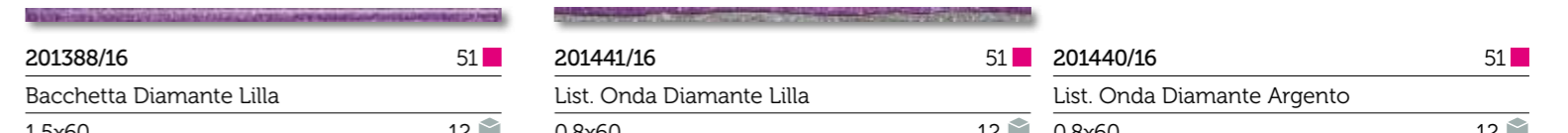

001086/10	31	201388/16	51	201441/16	51	201440/16	51
Tozzetto Diamante Lilla		Bacchetta Diamante Lilla		List. Onda Diamante Lilla		List. Onda Diamante Argento	
3x10	12	1,5x60	12	0,8x60	12	0,8x60	12

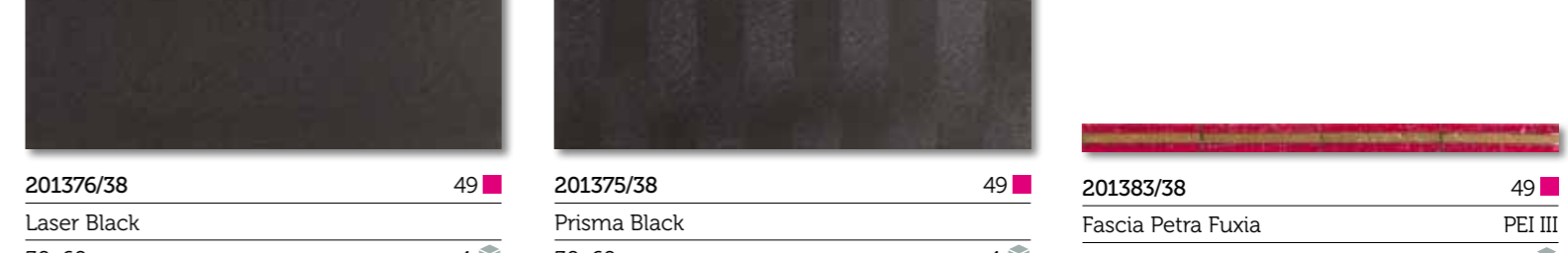

201376/38	49	201375/38	49	201383/38	49
Laser Black		Prisma Black		Fascia Petra Fuxia	PEI III
30x60	4	30x60	4	3,5x60	6

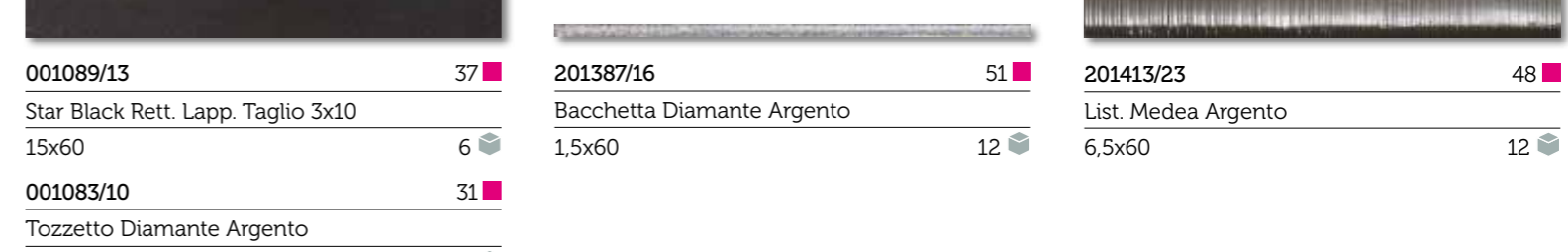

001089/13	37	201387/16	51	201413/23	48
Star Black Rett. Lapp. Taglio 3x10		Bacchetta Diamante Argento		List. Medea Argento	
15x60	6	1,5x60	12	6,5x60	12

Beige

	97 ■		94 ■		73 ■		60 ■
301200/55		301210/57		201239/186		201406/16	
Star Beige Rett. Lapp.	PEI III	Star Beige Rett. Lapp.	PEI III	Mosaico Star Beige		Raccordo Star Beige	
30x60	7	15x60	14	33,3x33,3 (su rete)	9	1,5x30	12

Brown

	97 ■		94 ■		73 ■		60 ■
301201/55		301212/57		201233/186		201409/16	
Star Brown Rett. Lapp.	PEI III	Star Brown Rett. Lapp.	PEI III	Mosaico Star Brown		Raccordo Star Brown	
30x60	7	15x60	14	33,3x33,3 (su rete)	9	1,5x30	12

	20		16
800886/07 Star Beige	23	201477/03	
800885/07 Star Brown	23	Tozzetto Star Brown	
		7x7	12

	97 ■		94 ■		97 ■		94 ■
301429/55		301218/57		301428/55		301220/57	
Star Beige Rett. Lapp.	PEI III	Star Beige Rett. Lapp.	PEI III	Star Brown Rett. Lapp.	PEI III	Star Brown Rett. Lapp.	PEI III
44,25x44,25	7	30x30	14	44,25x44,25	7	30x30	14

pesi e misure / weight and sizes / poids et mesures / Gewichte und Verpackungen	spessore thickness épaisseur stärke	pz/collo pcs/box pc/boite stk/ktn	mq/collo sqm/box m/boite qm/ktn	kg/collo kg/box kg/boite kg/ktn	colli/euopal box/euopal boites/euopal ktn/euopal	mq/euopal sqm/euopal m/euopal qm/euopal	kg/euopal kg/euopal kg/euopal kg/euopal
Fondo 15x60	9	14	1,26	24,8	40	50,4	1017
Fondo 30x60	9	7	1,26	25,1	60	75,6	1531
Mosaico 33,3x33,3	9	9	1	18,0			
Fondo 30x30	9	14	1,26	24,9	60	76,5	1519
Fondo 44,25x44,25	9	7	1,3706	25,0	52	71,29	1320

Decori / Decorations / Décorations / Dekors

	80 ■		75 ■		39 ■
201401/50		201385/91 *		001060/15	
Brix Beige		Brillance A		Modus Star Brown	
30x60	4	30x60	4	30x60	6
	37 ■		81 ■		39 ■
001087/13		201386/55 *		001173/15	
Star Beige Rett. Lapp. Taglio 3x10		Brillance B		Modus Star Brown Rov.	
15x60	6	30x60	4	30x60	6
	31 ■		51 ■		39 ■
001084/10		201390/16		001059/15	
Tozzetto Diamante Bronzo		Bacchetta Diamante Bronzo		Modus Star Beige	
3x10	12	1,5x60	12	30x60	6
	51 ■		51 ■		39 ■
201390/16		201442/16		001171/15	
List. Onda Diamante Bronzo		List. Onda Diamante Bronzo		Modus Star Beige Rov.	
0,8x60	12	0,8x60	12	30x60	6
	51 ■		49 ■		48 ■
201443/16		201384/38		201415/23	
List. Onda Diamante Oro		Fascia Petra Arancio	PEI III	List. Medea Rame	
0,8x60	12	3,5x60	6	6,5x60	12
	37 ■		51 ■		31 ■
001090/13		201389/16		001082/10	
Star Brown Rett. Lapp. Taglio 3x10		Bacchetta Diamante Oro		Tozzetto Diamante Oro	
15x60	6	1,5x60	12	3x10	12

note / notes / notes / anmerkungen

* È possibile abbinare questo decoro con fondo Star Beige Rett. Lapp. e Star White Rett. Lapp.
This decoration can be combined with a Star Beige Rett. Lapp. and a Star White Rett. Lapp. base tile /
Il est possible de combiner ce décor à un fond Star Beige Rett. Lapp. et Star White Rett. Lapp. /
Dieses Dekorelement kann mit der Grundfliese Star Beige Rett. Lapp. und Star White Rett. Lapp. kombiniert werden.



Prodotto con leggera variazione cromatica.
Light to moderate shade / Produit à légère variation chromatique / Produkt mit leichter Farbnuance.

quarzite



TT0855 Espositore serie Stardust

cm 64x115x162 1
Pannelli cm 64x137 5



TTP035 Pannello Sinottico serie Stardust
cm 100x200

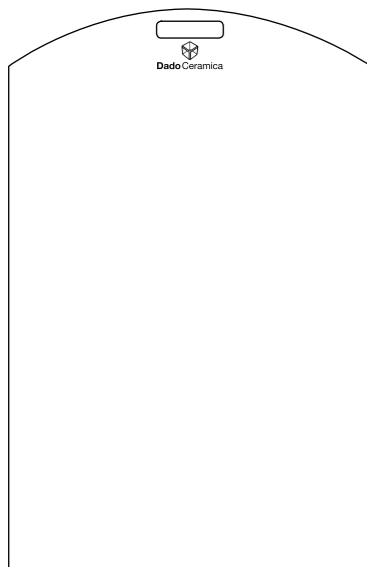

Faesite serie Stardust
cm 65x87

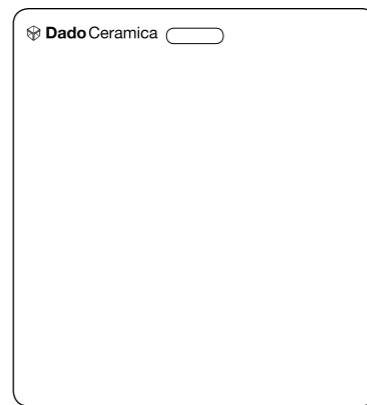

Faesite serie Stardust
cm 62x68



TTP033 Pannello Sinottico serie Stardust
cm 100x200

Rivestimento e pavimento in gres porcellanato rettificato lappato antiacido, antimacchia
Rectified, lapped, acid-resistant, stain-resistant porcelain stoneware wall and floor tiles
Revêtement et sol en grès cérame rectifié, rodé, anti-acide, anti-tache
Verkleidung und Boden aus Feinsteinzeug, geschliff., geläpft, säurefest, fleckenabweisend

30x60 - 15x60 - 30x30 - 44,25x44,25
12"x24" - 6"x24" - 12"x12" - 18"x18"



Beige



301194/55 97 ■
Quarzite Beige Rett. Lapp. PEI III
30x60 7



301206/57 94 ■
Quarzite Beige Rett. Lapp. PEI III
15x60 14

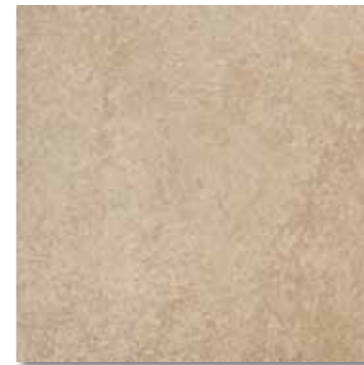

301434/55 97 ■
Quarzite Beige Rett. Lapp. PEI III
44,25x44,25 7



301214/57 PEI III 94 ■
Quarzite Beige Rett. Lapp.
30x30 14



201405/16 60 ■
Raccordo Quarzite Beige
1,5x30 12

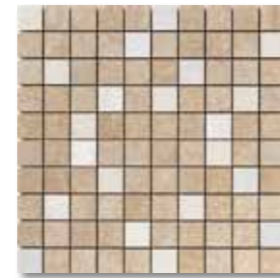

301238/186 73 ■
Mosaico Quarzite Beige
33,3x33,3 (su rete) 9

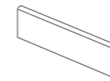

Battiscopa 7x60 20
DA2364/07 Quarzite Beige 23 ■

Marrone



301196/55 97 ■
Quarzite Marrone Rett. Lapp. PEI III
30x60 7



301208/57 94 ■
Quarzite Marrone Rett. Lapp. PEI III
15x60 14

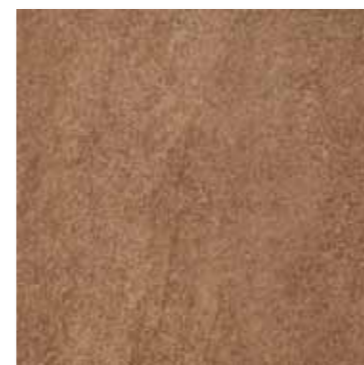

301443/55 97 ■
Quarzite Marrone Rett. Lapp. PEI III
44,25x44,25 7



301216/57 PEI III 94 ■
Quarzite Marrone Rett. Lapp.
30x30 14



201410/16 60 ■
Raccordo Quarzite Marrone
1,5x30 12



301235/186 73 ■
Mosaico Quarzite Marrone
33,3x33,3 (su rete) 9

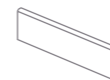

Battiscopa 7x60 20
DA2363/07 Quarzite Marrone 23 ■

Decor / Decorations / Décorations / Dekors



201380/55 81 ■
Intreccio Beige
30x60 4



001063/15 39 ■
Modus Quarzite Marrone
30x60 6



201379/55 81 ■
Intreccio Marrone
30x60 4

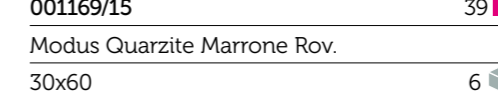

001169/15 39 ■
Modus Quarzite Marrone Rov.
30x60 6



001061/15 39 ■
Modus Quarzite Beige
30x60 6



001175/15 39 ■
Modus Quarzite Beige Rov.
30x60 6



201415/23 48 ■
List. Medea Rame
6,5x60 12



201384/38 49 ■
Fascia Petra Arancio PEI III
3,5x60 6



201389/16 51 ■
Bacchetta Diamante Oro
1,5x60 12



201390/16 51 ■
Bacchetta Diamante Bronzo
1,5x60 12



201442/16 51 ■
Listello Onda Diamante Bronzo
0,8x60 12



201443/16 51 ■
Listello Onda Diamante Oro
0,8x60 12

pesi e misure / weight and sizes / poids et mesures / Gewichte und Verpackungen							
dimensioni sizes dimensions abmessungen	spessore thickness épaisseur stärke	pz/collo pcs/box pc/boite stk/ktn	mq/collo sqm/box m/boite qm/ktn	kg/collo kg/box kg/boite kg/ktn	colli/europal box/europal boites/europal ktn/europal	mq/europal sqm/europal m/europal qm/europal	kg/europal kg/europal kg/europal kg/europal
Fondo 30x30	9 mm	14	1,26	24,9	60	75,6	1519
Fondo 15x60	9 mm	14	1,26	24,8	40	50,4	1017
Fondo 30x60	9 mm	7	1,26	25,1	60	75,6	1531
Mosaico 33,3x33,3	9 mm	9	1	18			
Fondo 44,25x44,25	9 mm	7	1,371	25	52	71,29	1320

Sabbia



301197/55 97 ■
Quarzite Sabbia Rett. Lapp. PEI III
30x60 7



301209/57 94 ■
Quarzite Sabbia Rett. Lapp. PEI III
15x60 14



301433/55 97 ■
Quarzite Sabbia Rett. Lapp. PEI III
44,25x44,25 7



301217/57 PEI III 94 ■
Quarzite Sabbia Rett. Lapp.
30x30 14



201407/16 60 ■
Raccordo Quarzite Sabbia
1,5x30 12

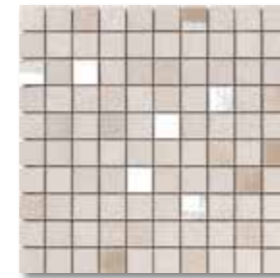

301237/186 73 ■
Mosaico Quarzite Sabbia
33,3x33,3 (su rete) 9

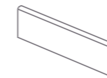

Battiscopa 7x60 20
DA2476/07 Quarzite Sabbia 23 ■

Grigio



301195/55 97 ■
Quarzite Grigio Rett. Lapp. PEI III
30x60 7



301207/57 94 ■
Quarzite Grigio Rett. Lapp. PEI III
15x60 14



301432/55 97 ■
Quarzite Grigio Rett. Lapp. PEI III
44,25x44,25 7



301215/57 PEI III 94 ■
Quarzite Grigio Rett. Lapp.
30x30 14



201404/16 60 ■
Raccordo Quarzite Grigio
1,5x30 12

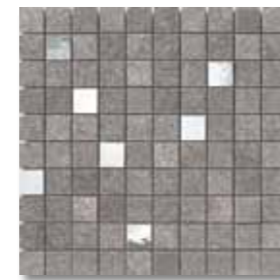

301234/186 73 ■
Mosaico Quarzite Grigio
33,3x33,3 (su rete) 9

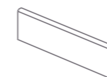

Battiscopa 7x60 20
DA2358/07 Quarzite Grigio 23 ■

Decor / Decorations / Décorations / Dekors



201381/55 81 ■
Intreccio Sabbia
30x60 4



001062/15 39 ■
Modus Quarzite Grigio
30x60 6



201382/55 81 ■
Intreccio Grigio
30x60 4



001168/15 39 ■
Modus Quarzite Grigio Rov.
30x60 6

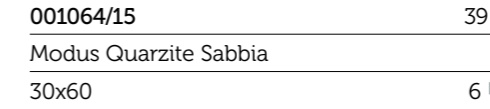

001064/15 39 ■
Modus Quarzite Sabbia
30x60 6

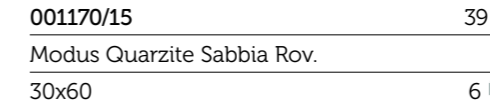

001170/15 39 ■
Modus Quarzite Sabbia Rov.
30x60 6



201413/23 48 ■
List. Medea Argento
6,5x60 12



201383/38 49 ■
Fascia Petra Fuxia PEI III
3,5x60 6



R02359/16 51 ■
Bacchetta Tribeca
2,1x60 10



201387/16 51 ■
Bacchetta Diamante Argento
1,5x60 12



201388/16 51 ■
Bacchetta Diamante Lilla
1,5x60 12



201440/16 51 ■
Listello Onda Diamante Argento
0,8x60 12

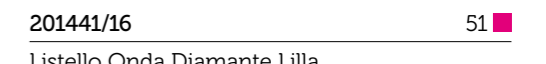

201441/16 51 ■
Listello Onda Diamante Lilla
0,8x60 12

pesi e misure / weight and sizes / poids et mesures / Gewichte und Verpackungen								
dimensioni sizes dimensions abmessungen	spessore thickness épaisseur stärke	pz/collo pcs/box pc/boite stk/ktn	mq/collo sqm/box m/boite qm/ktn	kg/collo kg/box kg/boite kg/ktn	colli/europal box/europal boites/europal ktn/europal	mq/europal sqm/europal m/europal qm/europal	kg/europal kg/europal kg/europal kg/europal	
Fondo 30x30	9 mm	14	1,26	24,9	60	75,6	1519	
Fondo 15x60	9 mm	14	1,26	24,8	40	50,4	1017	
Fondo 30x60	9 mm	7	1,26	25,1	60	75,6	1531	
Mosaico 33,3x33,3	9 mm	9	1	18				
Fondo 44,25x44,25	9 mm	7	1,371	25	52	71,29	1320	



TT0856 Espositore serie Quarzite

cm 64x115x162	1
Pannelli cm 64x137	6

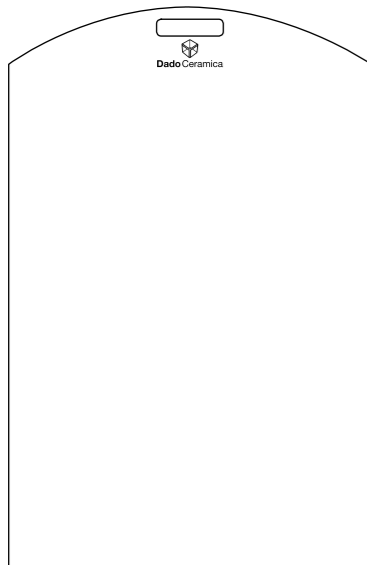

Faesite serie Quarzite

cm 65x87

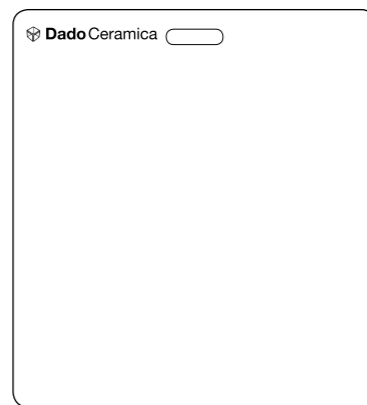

Faesite serie Quarzite

cm 62x68



TTP034 Pannello Sinottico serie Quarzite

cm 100x200

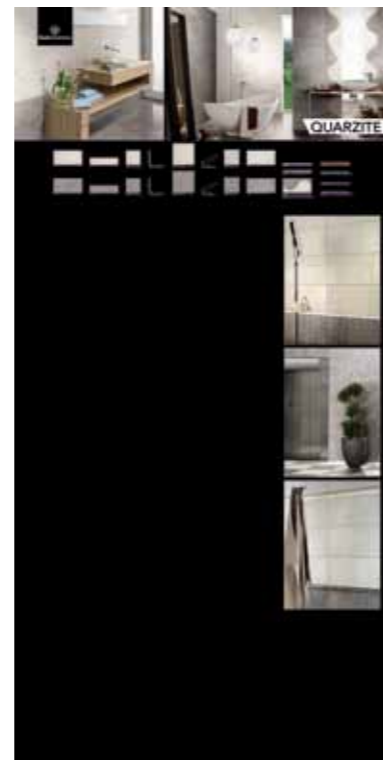

TTP037 Pannello Sinottico serie Quarzite

cm 100x200



Prodotto con leggera variazione cromatica.
 Light to moderate shade / Produit à légère variation chromatique / Produkt mit leichter Farbnuance.

the big apple

Rivestimento e pavimento in gres porcellanato smaltato rettificato a tutta massa

Full-body rectified, glazed porcelain stoneware wall and floor coverings

Revêtement et sol en grès cérame émaillé rectifié pleine masse
 Verkleidung und Fußboden aus glasiertem, geschliffenem, vollgemischtem Feinsteinzeug

60x60 - 30x60
24"x24" - 12"x24"



Rivestimento e pavimento in gres porcellanato smaltato
rettificato a tutta massa
Full-body rectified, glazed porcelain stoneware wall and floor coverings

Bronx



R02340/56 93 ■
Bronx Rett. PEI IV R9
60x60 4



R02341/61 95 ■
Bronx Rett. PEI IV R9
30x60 6

Queens



R02338/51 92 ■
Queens Rett. PEI IV R9
60x60 4



R02339/57 94 ■
Queens Rett. PEI IV R9
30x60 6

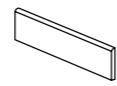

Battiscopa 8,5x60 20 ■
R02374/07 Bronx 22 ■
R02373/07 Queens 22 ■
R02371/07 Manhattan 22 ■
R02424/07 Staten Island 22 ■
R02372/07 Brooklyn 22 ■

Manhattan



R02334/56 93 ■
Manhattan Rett. PEI IV R9
60x60 4



R02335/61 95 ■
Manhattan Rett. PEI IV R9
30x60 6



R301224/64 98 ■
Manhattan Rett. 10x60
10x60 15

State Island



R02403/51 92 ■
Staten Island Rett. PEI IV R9
60x60 4



R02404/57 94 ■
Staten Island Rett. PEI IV R9
30x60 6

Brooklyn

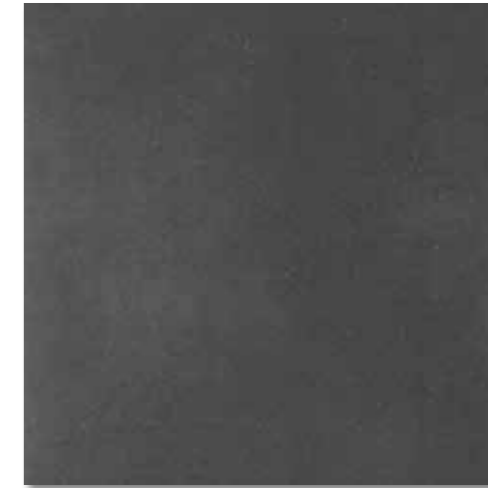

R02336/56 93 ■
Brooklyn Rett. PEI IV R9
60x60 4



R02337/61 95 ■
Brooklyn Rett. PEI IV R9
30x60 6



R301223/64 98 ■
Brooklyn Rett.
10x60 15

Decori / Decorations / Décorations / Dekors



R201368/113 71 ■
Lincoln Brown
30x60 4



R201366/32 66 ■
Fascia Lexington Oro
7x60 6



R201363/45 87 ■
Broadway Beige
30x60 4



R201362/59 57 ■
Madison Brown
30x60 4

note / notes / notes / anmerkungen

Fondi Rettificati 60x60 vendibili a multipli di colli 3
60x60 rectified tile sold by 3 boxes bound together, i.e. 3 and multiples of 3 / fonds rectifiés 60x60 vendables par multiples de 3 colis / geschliffene Grundfliesen 60x60, in 3er-Pack verkäuflich

Fondi Rettificati 30x60 vendibili a multipli di colli 2
30x60 rectified tile sold by 2 boxes bound together, i.e. 2 and multiples of 2 / fonds rectifiés 30x60 vendables par multiples de 2 colis / geschliffene Grundfliesen 30x60, in 2er-Pack verkäuflich

pesi e misure / weight and sizes / poids et mesures / Gewichte und Verpackungen

dimensioni sizes dimensions abmessungen	spessore thickness épaisseur stärke	pz/collo pcs/box pc/boite stk/ktn	mq/collo sqm/box m/boite qm/ktn	kg/collo kg/box kg/boite kg/ktn	colli/euopal box/euopal boites/euopal ktn/euopal	mq/euopal sqm/euopal m/euopal qm/euopal	kg/euopal kg/euopal kg/euopal kg/euopal
Fondo 10x60 Rett.	9,5 mm	15	0,90	20,50	60	54,00	1250
Fondo 30x60 Rett.	9,5 mm	7	1,26	26,00	40	50,40	1065
Fondo 60x60 Rett.	9,5 mm	5	1,80	36,25	24	43,20	890

Manhattan



R02334/56 93 ■
Manhattan Rett. PEI IV R9
60x60 4



R02335/61 95 ■
Manhattan Rett. PEI IV R9
30x60 6



R301224/64 98 ■
Manhattan Rett. 10x60
10x60 15

Decori / Decorations / Décorations / Dekors



R201367/113 71 ■
Lincoln Antracite
30x60 4



R201365/32 66 ■
Fascia Lexington Argento
7x60 6



R201364/45 87 ■
Broadway Grigio
30x60 4



R02359/12 35 ■
Fascia Tribeca
2,1x60 10

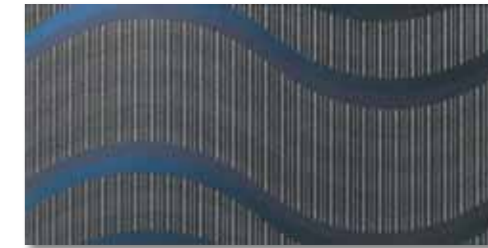

R201361/59 57 ■
Madison Antracite
30x60 4



TT0817 Espositore serie The Big Apple

cm 64x115x162 1
Pannelli cm 64x137 6

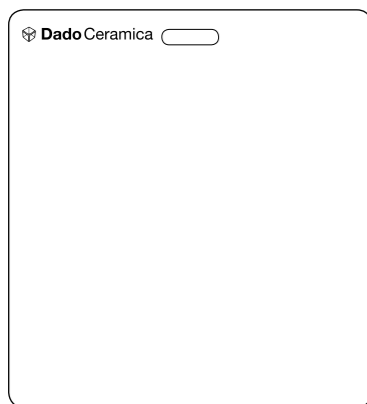

Faesite serie The Big Apple

cm 62x68

merchandising

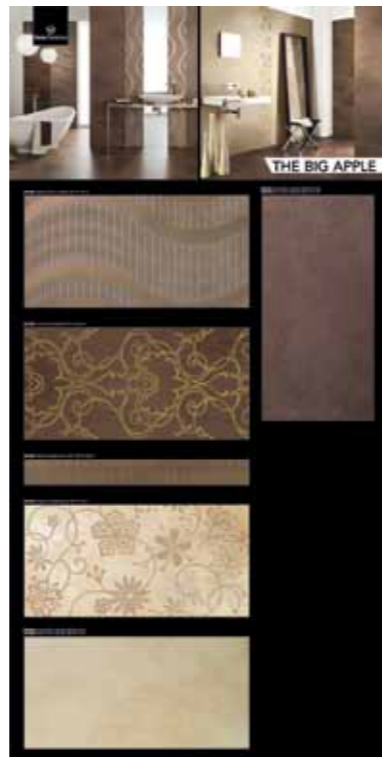

TTP032 Pannello Sinottico serie The Big Apple

cm 100x200

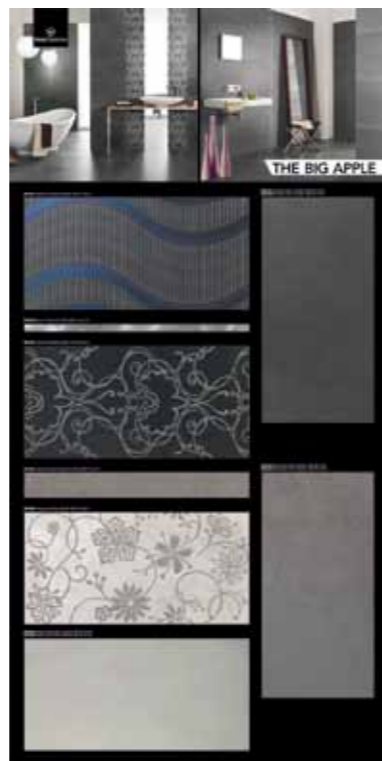

TTP031 Pannello Sinottico serie The Big Apple

cm 100x200



Prodotto con marcata variazione cromatica.
High shade texture variation within each carton.
Produit à variation chromatique accentuée.
Produkt mit ausgeprägter Farbnuance.

rovere
rovere out

89 - 106

rovere

Gres porcellanato smaltato

Glazed porcelain stoneware

Grès cérame émaillé

Glasiertes Feinsteinzeug

20,5x83 - 13,5x83 - 31x62 - 15x60,6 - 7,5x60,6
8"x32,6" - 5"x32,6" - 12"x24" - 6"x24" - 3"x24"

rovere out

Gres porcellanato smaltato

Glazed porcelain stoneware

Grès cérame émaillé

Glasiertes Feinsteinzeug

31x62 - 15,5x62
12"x24" - 6"x24"



Rovere Biondo



Rovere Antico



Rovere Blanchis



Rovere Biondo



Rovere Moka





Rovere Grigio



Rovere Bianco

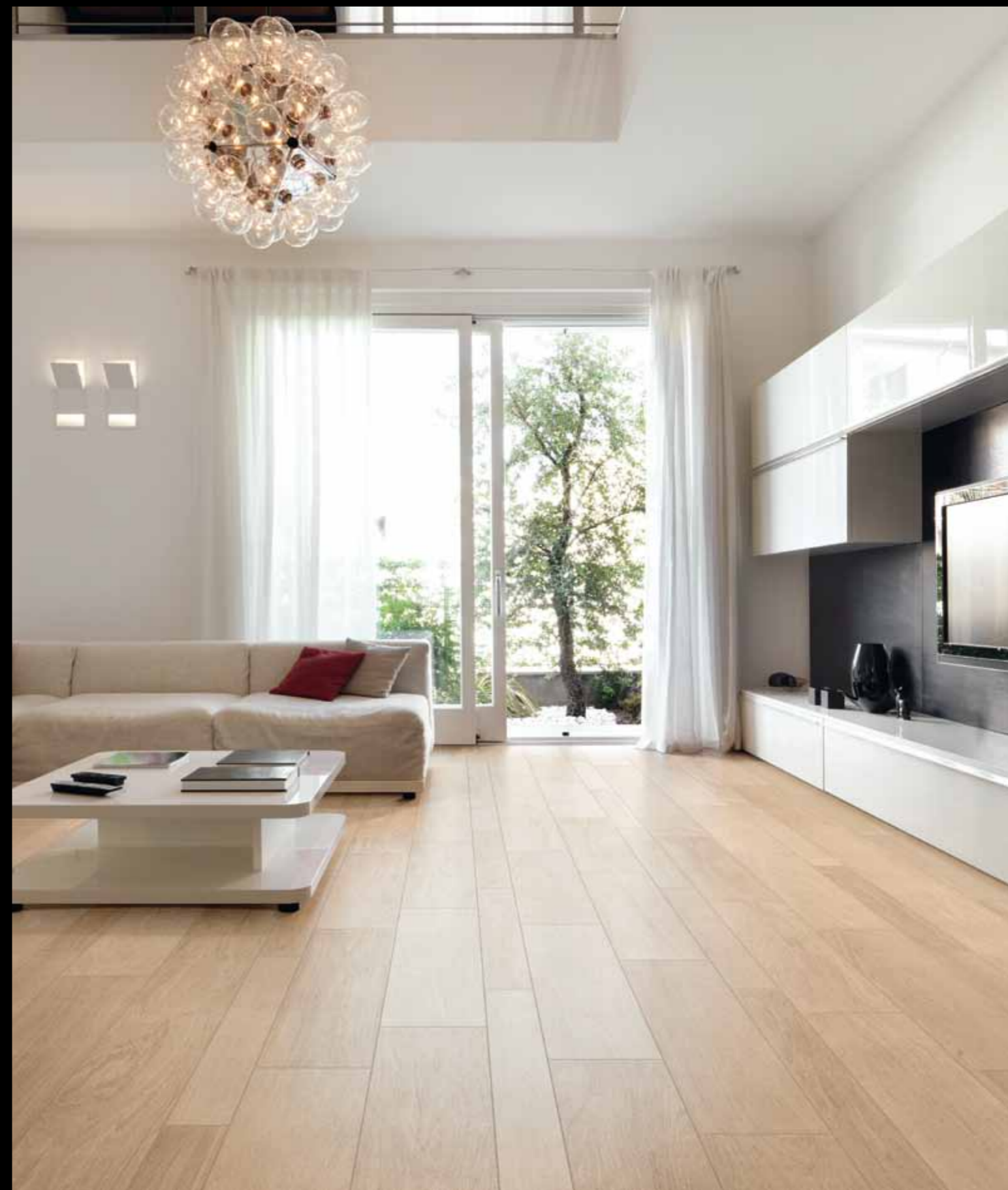

Rovere Naturale



Rovere Bianco



Blanchis



301513/27 07 ■
Rovere Blanchis Nat. PEI IV
31x62 7



301515/40 15 ■
Rovere Blanchis Rett. PEI IV
15x60,6 14



301516/56 93 ■
Rovere Blanchis Rett. PEI IV
7,5x60,6 28



302440/55 97 ■
Rovere Blanchis Rett. PEI IV
20,5x83 6



302439/61 95 ■
Rovere Blanchis Rett. PEI IV
13,5x83 7



301517/113 71 ■
Mosaico Riga Rovere Blanchis PEI IV
30x60 (su rete) 7



301518/157 68 ■
Mosaico Stuoia Rovere Blanchis PEI IV
30x30 (su rete) 11

Pezzi speciali / Special trims / Pièces spéciales / Spezielle Teile

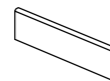

Battiscopa 7,2x62 20
800391/06 Blanchis 22

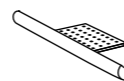

Toro Luna Lineare 30 8
800993/20 Blanchis 45

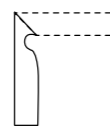

Battiscala 7,2 4
800987/20 Blanchis DX 45
800988/20 Blanchis SX 45

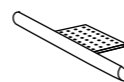

Toro Luna Lineare 60 4
800994/40 Blanchis 15

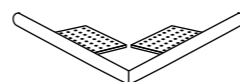

Angolare Toro Luna 4
800999/40 Blanchis x30 15
801000/80 Blanchis x60 70



Gradino Monolitico Elemento a Elle 2
801003/45 Blanchis 76
62x16x4,5

note / notes / notes / notes

⚡ **Attenzione!! Consultare l'istruzione per la posa contenuta all'interno della scatola del prodotto.**
Please note!! Refer to the installation instructions contained in the product packaging. /
Attention!! Consulter le mode d'emploi pour la pose, contenu dans la boîte du produit. /
Achtung!! Die Verlegeanleitungen in der Verpackung beachten.

pesi e misure / weight and sizes / poids et mesures / Gewichte und Verpackungen

dimensioni sizes dimensions abmessungen	spessore thickness épaisseur stärke	pz/collo pcs/box pc/boite stk/ktn	mq/collo sqm/box m/boite qm/ktn	kg/collo kg/box kg/boite kg/ktn	colli/eurolal box/eurolal boites/eurolal ktn/eurolal	mq/eurolal sqm/eurolal m/eurolal qm/eurolal	kg/eurolal kg/eurolal kg/eurolal kg/eurolal
Fondo Rovere 7,5x60,6	9 mm	28	1,273	22,50	40	50,92	915
Fondo Rovere 15x60,6	9 mm	14	1,273	22,50	40	50,92	920
Fondo Rovere 31x62	9 mm	7	1,35	23,00	60	81,00	1405
Fondo Rovere 20,5x83	10 mm	6	1,03	21,95	64	65,92	1420
Fondo Rovere 13,5x83	10 mm	10	1,13	24,08	50	56,50	1220
Mosaico Stuoia 30x30	9 mm	11	1,00	16,50	35	44,10	602
Mosaico Riga 30x60	9 mm	7	1,26	21,50	36	36,00	799

Grigio



301361/27 07 ■
Rovere Grigio Nat. PEI IV
31x62 7



301365/40 15 ■
Rovere Grigio Rett. PEI IV
15x60,6 14

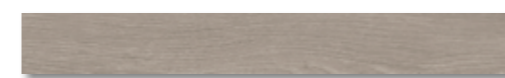

301386/56 93 ■
Rovere Grigio Rett. PEI IV
7,5x60,6 28



302443/55 97 ■
Rovere Grigio Rett. PEI IV
20,5x83 6



302442/61 95 ■
Rovere Grigio Rett. PEI IV
13,5x83 7



301411/113 71 ■
Mosaico Riga Rovere Grigio PEI IV
30x60 (su rete) 7



301415/157 68 ■
Mosaico Stuoia Rovere Grigio PEI IV
30x30 (su rete) 11

Pezzi speciali / Special trims / Pièces spéciales / Spezielle Teile

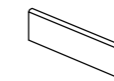

Battiscopa 7,2x62 20
800169/06 Grigio 22

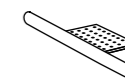

Toro Luna Lineare 30 8
800853/20 Grigio 45

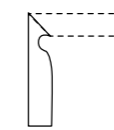

Battiscala 7,2 4
800867/20 Grigio DX 45
800868/20 Grigio SX 45

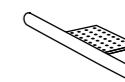

Toro Luna Lineare 60 4
800849/40 Grigio 15



Gradino Monolitico Elemento a Elle 2
801004/45 Grigio 76
62x16x4,5

note / notes / notes / notes

⚡ **Attenzione!! Consultare l'istruzione per la posa contenuta all'interno della scatola del prodotto.**
Please note!! Refer to the installation instructions contained in the product packaging. /
Attention!! Consulter le mode d'emploi pour la pose, contenu dans la boîte du produit. /
Achtung!! Die Verlegeanleitungen in der Verpackung beachten.

pesi e misure / weight and sizes / poids et mesures / Gewichte und Verpackungen

dimensioni sizes dimensions abmessungen	spessore thickness épaisseur stärke	pz/collo pcs/box pc/boite stk/ktn	mq/collo sqm/box m/boite qm/ktn	kg/collo kg/box kg/boite kg/ktn	colli/eurolal box/eurolal boites/eurolal ktn/eurolal	mq/eurolal sqm/eurolal m/eurolal qm/eurolal	kg/eurolal kg/eurolal kg/eurolal kg/eurolal
Fondo Rovere 7,5x60,6	9 mm	28	1,273	22,50	40	50,92	915
Fondo Rovere 15x60,6	9 mm	14	1,273	22,50	40	50,92	920
Fondo Rovere 31x62	9 mm	7	1,35	23,00	60	81,00	1405
Fondo Rovere 20,5x83	10 mm	6	1,03	21,95	64	65,92	1420
Fondo Rovere 13,5x83	10 mm	10	1,13	24,08	50	56,50	1220
Mosaico Stuoia 30x30	9 mm	11	1,00	16,50	35	44,10	602
Mosaico Riga 30x60	9 mm	7	1,26	21,50	36	36,00	799

Antico



301362/27 07 ■
Rovere Antico Nat. PEI IV
31x62 7



301366/40 15 ■
Rovere Antico Rett. PEI IV
15x60,6 14



301384/56 93 ■
Rovere Antico Rett. PEI IV
7,5x60,6 28



302446/55 97 ■
Rovere Antico Rett. PEI IV
20,5x83 6



302445/61 95 ■
Rovere Antico Rett. PEI IV
13,5x83 7



301412/113 71 ■
Mosaico Riga Rovere Antico PEI IV
30x60 (su rete) 7



301416/157 68 ■
Mosaico Stuoia Rovere Antico PEI IV
30x30 (su rete) 11

Pezzi speciali / Special trims / Pièces spéciales / Spezielle Teile

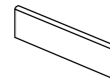

Battiscopa 7,2x62 20
800170/06 Antico 22

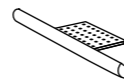

Toro Luna Lineare 30 8
800854/20 Antico 45

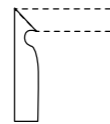

Battiscala 7,2 4
800869/20 Antico DX 45
800870/20 Antico SX 45

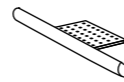

Toro Luna Lineare 60 4
800850/40 Antico 15

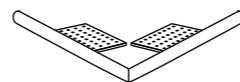

Angolare Toro Luna 4
800858/40 Antico x30 15
800862/80 Antico x60 70



Gradino Monolitico Elemento a Elle 2
801005/45 Antico 76
62x16x4,5

note / notes / notes / notes

⚡ **Attenzione!! Consultare l'istruzione per la posa contenuta all'interno della scatola del prodotto.**
Please note!! Refer to the installation instructions contained in the product packaging. /
Attention!! Consulter le mode d'emploi pour la pose, contenu dans la boîte du produit. /
Achtung!! Die Verlegeanleitungen in der Verpackung beachten.

pesi e misure / weight and sizes / poids et mesures / Gewichte und Verpackungen

dimensioni sizes dimensions abmessungen	spessore thickness épaisseur stärke	pz/collo pcs/box pc/boite stk/ktn	mq/collo sqm/box m/boite qm/ktn	kg/collo kg/box kg/boite kg/ktn	colli/eurolal box/eurolal boites/eurolal ktn/eurolal	mq/eurolal sqm/eurolal m/eurolal qm/eurolal	kg/eurolal kg/eurolal kg/eurolal kg/eurolal
Fondo Rovere 7,5x60,6	9 mm	28	1,273	22,50	40	50,92	915
Fondo Rovere 15x60,6	9 mm	14	1,273	22,50	40	50,92	920
Fondo Rovere 31x62	9 mm	7	1,35	23,00	60	81,00	1405
Fondo Rovere 20,5x83	10 mm	6	1,03	21,95	64	65,92	1420
Fondo Rovere 13,5x83	10 mm	10	1,13	24,08	50	56,50	1220
Mosaico Stuoia 30x30	9 mm	11	1,00	16,50	35	44,10	602
Mosaico Riga 30x60	9 mm	7	1,26	21,50	36	36,00	799

Bianco



301359/27 07 ■
Rovere Bianco Nat. PEI IV
31x62 7



301363/40 15 ■
Rovere Bianco Rett. PEI IV
15x60,6 14



301385/56 93 ■
Rovere Bianco Rett. PEI IV
7,5x60,6 28



302449/55 97 ■
Rovere Bianco Rett. PEI IV
20,5x83 6



302448/61 95 ■
Rovere Bianco Rett. PEI IV
13,5x83 7



301410/113 71 ■
Mosaico Riga Rovere Bianco PEI IV
30x60 (su rete) 7



301414/157 68 ■
Mosaico Stuoia Rovere Bianco PEI IV
30x30 (su rete) 11

Pezzi speciali / Special trims / Pièces spéciales / Spezielle Teile

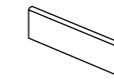

Battiscopa 7,2x62 20
800166/06 Bianco 22

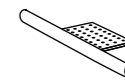

Toro Luna Lineare 30 8
800852/20 Bianco 45

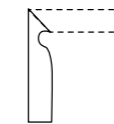

Battiscala 7,2 4
800865/20 Bianco DX 45
800866/20 Bianco SX 45

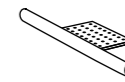

Toro Luna Lineare 60 4
800848/40 Bianco 15



Gradino Monolitico Elemento a Elle 2
801006/45 Bianco 76
62x16x4,5

note / notes / notes / notes

⚡ **Attenzione!! Consultare l'istruzione per la posa contenuta all'interno della scatola del prodotto.**
Please note!! Refer to the installation instructions contained in the product packaging. /
Attention!! Consulter le mode d'emploi pour la pose, contenu dans la boîte du produit. /
Achtung!! Die Verlegeanleitungen in der Verpackung beachten.

pesi e misure / weight and sizes / poids et mesures / Gewichte und Verpackungen

dimensioni sizes dimensions abmessungen	spessore thickness épaisseur stärke	pz/collo pcs/box pc/boite stk/ktn	mq/collo sqm/box m/boite qm/ktn	kg/collo kg/box kg/boite kg/ktn	colli/eurolal box/eurolal boites/eurolal ktn/eurolal	mq/eurolal sqm/eurolal m/eurolal qm/eurolal	kg/eurolal kg/eurolal kg/eurolal kg/eurolal
Fondo Rovere 7,5x60,6	9 mm	28	1,273	22,50	40	50,92	915
Fondo Rovere 15x60,6	9 mm	14	1,273	22,50	40	50,92	920
Fondo Rovere 31x62	9 mm	7	1,35	23,00	60	81,00	1405
Fondo Rovere 20,5x83	10 mm	6	1,03	21,95	64	65,92	1420
Fondo Rovere 13,5x83	10 mm	10	1,13	24,08	50	56,50	1220
Mosaico Stuoia 30x30	9 mm	11	1,00	16,50	35	44,10	602
Mosaico Riga 30x60	9 mm	7	1,26	21,50	36	36,00	799

Biondo



301360/27 07 ■
Rovere Biondo Nat. PEI IV
31x62 7



301364/40 15 ■
Rovere Biondo Rett. PEI IV
15x60,6 14

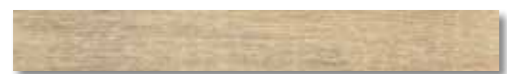

301380/56 93 ■
Rovere Biondo Rett. PEI IV
7,5x60,6 28



302452/55 97 ■
Rovere Biondo Rett. PEI IV
20,5x83 6



302451/61 95 ■
Rovere Biondo Rett. PEI IV
13,5x83 7



301409/113 71 ■
Mosaico Riga Rovere Biondo PEI IV
30x60 (su rete) 7



301413/157 68 ■
Mosaico Stuoia Rovere Biondo PEI IV
30x30 (su rete) 11

Pezzi speciali / Special trims / Pièces spéciales / Spezielle Teile

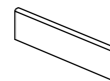

Battiscopa 7,2x62 20
800165/06 Biondo 22

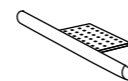

Toro Luna Lineare 30 8
800851/20 Biondo 45

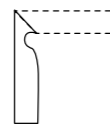

Battiscala 7,2 4
800863/20 Biondo DX 45
800864/20 Biondo SX 45

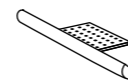

Toro Luna Lineare 60 4
800847/40 Biondo 15

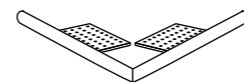

Angolare Toro Luna 4
800855/40 Biondo x30 15
800859/80 Biondo x60 70



Gradino Monolitico Elemento a Elle 2
801007/45 Biondo 76
62x16x4,5

note / notes / notes / notes

⚡ **Attenzione!!** Consultare l'istruzione per la posa contenuta all'interno della scatola del prodotto.
Please note!! Refer to the installation instructions contained in the product packaging. /
Attention!! Consulter le mode d'emploi pour la pose, contenu dans la boîte du produit. /
Achtung!! Die Verlegeanleitungen in der Verpackung beachten.

pesi e misure / weight and sizes / poids et mesures / Gewichte und Verpackungen

dimensioni sizes dimensions abmessungen	spessore thickness épaisseur stärke	pz/collo pcs/box pc/boite stk/ktn	mq/collo sqm/box m/boite qm/ktn	kg/collo kg/box kg/boite kg/ktn	colli/eurolal box/eurolal boites/eurolal ktn/eurolal	mq/eurolal sqm/eurolal m/eurolal qm/eurolal	kg/eurolal kg/eurolal kg/eurolal kg/eurolal
Fondo Rovere 7,5x60,6	9 mm	28	1,273	22,50	40	50,92	915
Fondo Rovere 15x60,6	9 mm	14	1,273	22,50	40	50,92	920
Fondo Rovere 31x62	9 mm	7	1,35	23,00	60	81,00	1405
Fondo Rovere 20,5x83	10 mm	6	1,03	21,95	64	65,92	1420
Fondo Rovere 13,5x83	10 mm	10	1,13	24,08	50	56,50	1220
Mosaico Stuoia 30x30	9 mm	11	1,00	16,50	35	44,10	602
Mosaico Riga 30x60	9 mm	7	1,26	21,50	36	36,00	799

Naturale



301489/27 07 ■
Rovere Naturale Nat. PEI IV
31x62 7



301494/40 15 ■
Rovere Naturale Rett. PEI IV
15x60,6 14



301497/56 93 ■
Rovere Naturale Rett. PEI IV
7,5x60,6 28



302458/55 97 ■
Rovere Naturale Rett. PEI IV
20,5x83 6



302457/61 95 ■
Rovere Naturale Rett. PEI IV
13,5x83 7



301498/113 71 ■
Mosaico Riga Rovere Naturale PEI IV
30x60 (su rete) 7



301499/157 68 ■
Mosaico Stuoia Rovere Naturale PEI IV
30x30 (su rete) 11

Pezzi speciali / Special trims / Pièces spéciales / Spezielle Teile

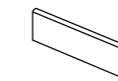

Battiscopa 7,2x62 20
800390/06 Naturale 22

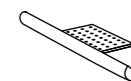

Toro Luna Lineare 30 8
800991/20 Naturale 45

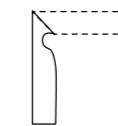

Battiscala 7,2 4
800985/20 Naturale DX 45
800986/20 Naturale SX 45

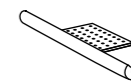

Toro Luna Lineare 60 4
800992/40 Naturale 15



Gradino Monolitico Elemento a Elle 2
801009/45 Naturale 76
62x16x4,5

note / notes / notes / notes

⚡ **Attenzione!!** Consultare l'istruzione per la posa contenuta all'interno della scatola del prodotto.
Please note!! Refer to the installation instructions contained in the product packaging. /
Attention!! Consulter le mode d'emploi pour la pose, contenu dans la boîte du produit. /
Achtung!! Die Verlegeanleitungen in der Verpackung beachten.

pesi e misure / weight and sizes / poids et mesures / Gewichte und Verpackungen

dimensioni sizes dimensions abmessungen	spessore thickness épaisseur stärke	pz/collo pcs/box pc/boite stk/ktn	mq/collo sqm/box m/boite qm/ktn	kg/collo kg/box kg/boite kg/ktn	colli/eurolal box/eurolal boites/eurolal ktn/eurolal	mq/eurolal sqm/eurolal m/eurolal qm/eurolal	kg/eurolal kg/eurolal kg/eurolal kg/eurolal
Fondo Rovere 7,5x60,6	9 mm	28	1,273	22,50	40	50,92	915
Fondo Rovere 15x60,6	9 mm	14	1,273	22,50	40	50,92	920
Fondo Rovere 31x62	9 mm	7	1,35	23,00	60	81,00	1405
Fondo Rovere 20,5x83	10 mm	6	1,03	21,95	64	65,92	1420
Fondo Rovere 13,5x83	10 mm	10	1,13	24,08	50	56,50	1220
Mosaico Stuoia 30x30	9 mm	11	1,00	16,50	35	44,10	602
Mosaico Riga 30x60	9 mm	7	1,26	21,50	36	36,00	799

Moka



301514/27 07 ■
Rovere Moka Nat. PEI IV
31x62 7

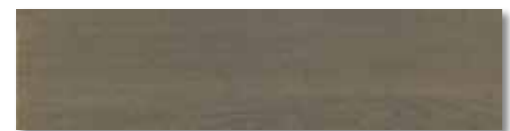

301519/40 15 ■
Rovere Moka Rett. PEI IV
15x60,6 14



301520/56 93 ■
Rovere Moka Rett. PEI IV
7,5x60,6 28



302455/55 97 ■
Rovere Moka Rett. PEI IV
20,5x83 6



302454/61 95 ■
Rovere Moka Rett. PEI IV
13,5x83 7



301521/113 71 ■
Mosaico Riga Rovere Moka PEI IV
30x60 (su rete) 7



301522/157 68 ■
Mosaico Stuoia Rovere Moka PEI IV
30x30 (su rete) 11

Pezzi speciali / Special trims / Pièces spéciales / Spezielle Teile

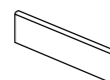

Battiscopa 7,2x62 20 ■
800392/06 Moka 22 ■

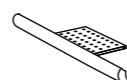

Toro Luna Lineare 30 8 ■
800995/20 Moka 45 ■

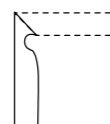

Battiscala 7,2 4 ■
800989/20 Moka DX 45 ■
800990/20 Moka SX 45 ■

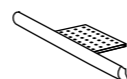

Toro Luna Lineare 60 4 ■
800996/40 Moka 15 ■

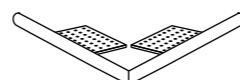

Angolare Toro Luna 4 ■
801001/40 Moka x30 15 ■
801002/80 Moka x60 70 ■



Gradino Monolitico Elemento a Elle 2 ■
801008/45 Moka 76 ■
62x16x4,5

note / notes / notes / notes

⚡ **Attenzione!! Consultare l'istruzione per la posa contenuta all'interno della scatola del prodotto.**
Please note!! Refer to the installation instructions contained in the product packaging. /
Attention!! Consulter le mode d'emploi pour la pose, contenu dans la boîte du produit. /
Achtung!! Die Verlegeanleitungen in der Verpackung beachten.

pesi e misure / weight and sizes / poids et mesures / Gewichte und Verpackungen							
dimensioni sizes dimensions abmessungen	spessore thickness épaisseur stärke	pz/collo pcs/box pc/boite stk/ktn	mq/collo sqm/box m/boite qm/ktn	kg/collo kg/box kg/boite kg/ktn	colli/eurolap box/eurolap boites/eurolap ktn/eurolap	mq/eurolap sqm/eurolap m/eurolap qm/eurolap	kg/eurolap kg/eurolap kg/eurolap kg/eurolap
Fondo Rovere 7,5x60,6	9 mm	28	1,273	22,50	40	50,92	915
Fondo Rovere 15x60,6	9 mm	14	1,273	22,50	40	50,92	920
Fondo Rovere 31x62	9 mm	7	1,35	23,00	60	81,00	1405
Fondo Rovere 20,5x83	10 mm	6	1,03	21,95	64	65,92	1420
Fondo Rovere 13,5x83	10 mm	10	1,13	24,08	50	56,50	1220
Mosaico Stuoia 30x30	9 mm	11	1,00	16,50	35	44,10	602
Mosaico Riga 30x60	9 mm	7	1,26	21,50	36	36,00	799

Schemi di posa / Laying patterns / Schémas de pose / Verlegungsschemen

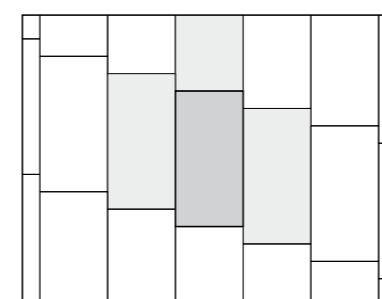

formati sizes	pz / modulo	% / mq	pz / mq
31x62	1	100	5,20

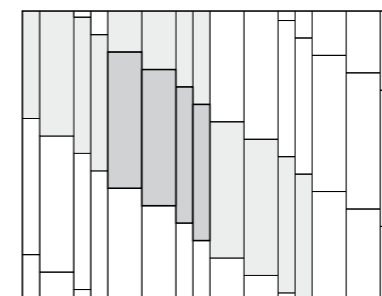

formati sizes	pz / modulo	% / mq	pz / mq
15x60,6	2	66,7	7,34
7,5x60,6	2	33,3	7,34

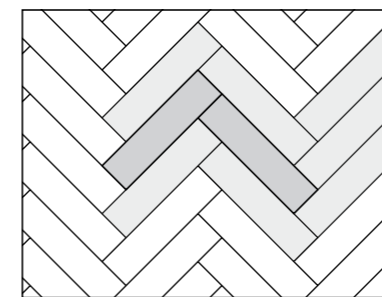

formati sizes	pz / modulo	% / mq	pz / mq
15x60,6	2	100	11,00

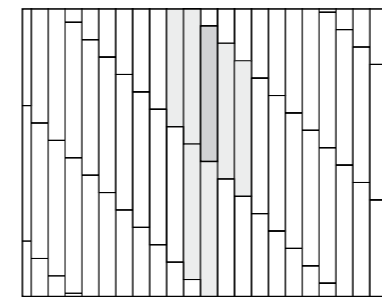

formati sizes	pz / modulo	% / mq	pz / mq
7,5x60,6	1	100	22

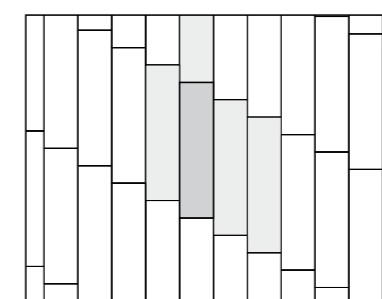
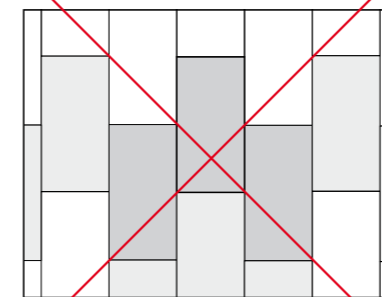

formati sizes	pz / modulo	% / mq	pz / mq
15x60,6	1	100	11

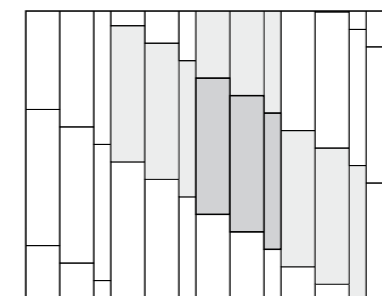

formati sizes	pz / modulo	% / mq	pz / mq
15x60,6	2	80	8,80
7,5x60,6	1	20	4,40

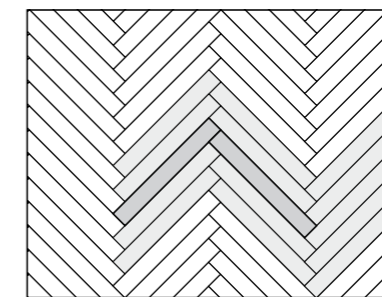

formati sizes	pz / modulo	% / mq	pz / mq
7,5x60,6	2	100	22,00

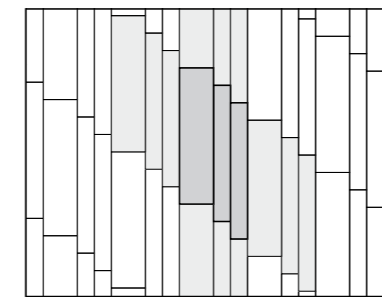

formati sizes	pz / modulo	% / mq	pz / mq
15x60,6	1	50	5,50
7,5x60,6	2	50	11,00

Non è consigliabile posare il materiale sfalsato di 1/2 (30-30,5 cm).

We do not recommend laying the material in a 1/2 (30-30.5 cm) staggered pattern.
Il est déconseillé de poser le matériau avec un décalage de 1/2 (30-30,5 cm).
Es ist nicht empfehlenswert, das Material 1/2 (30-30,5 cm) versetzt zu verlegen.

ecodado+™

risparmio energetico fino al 10% con il riscaldamento a pavimento

Rispetto al legno, che non è un buon conduttore (la resistenza termica di un pavimento in legno varia da 0,10 – 0,18 m² K/W), il nostro "legno" in gres porcellanato (la cui resistenza termica di un pavimento varia da 0,01 – 0,02 m² K/W) offre prestazioni di eccellenza, poiché favorisce l'ottimizzazione del sistema completo con temperature più basse dell'acqua di circa 5°C e di conseguenza il risparmio energetico dell'intero impianto che varia da un 8/10%.

up to 10% energy savings with underfloor heating

Compared to wood, a poor conductor of heat (the thermal resistance of a wooden floor is between 0.10 and 0.18 m² K/W), our porcelain stoneware "wood" floors (with a thermal resistance of between 0.01 and 0.02 m² K/W) offers excellent performance, because it helps optimise the whole system, with water temperatures of around 5°C lower and thus a total energy saving of between 8 and 10%.

économie énergétique allant jusqu'à 10% avec chauffage au sol

Par rapport au bois, qui n'est pas un bon conducteur (la résistance thermique d'un sol en bois varie de 0,10 à 0,18 m² K/W), notre "bois" en grès cérame (dont la résistance thermique d'un sol varie de 0,01 à 0,02 m² K/W) offre d'excellentes prestations dans la mesure où il favorise l'optimisation du système complet avec des températures plus basses que l'eau d'environ 5°C. Par conséquent, l'économie énergétique de l'ensemble de l'installation varie de 8 à 10%.

Energieeinsparung um bis zu 10% mit Fußbodenheizung

Im Vergleich zu Holz ist es kein guter Leiter (der Wärmewiderstand eines Holzbodens liegt zwischen 0,10 und 0,18 m² K/W), unser "Holz" aus Feinsteinzeug (bei dem der Wärmewiderstand eines Fußbodens zwischen 0,01 und 0,02 m² K/W liegt) bietet ausgezeichnete Leistungen, da es die Optimierung des kompletten Systems bei um ungefähr 5°C niedrigeren Wassertemperaturen und folglich eine Energieeinsparung der gesamten Anlage zwischen 8 und 10% fördert.



Rovere Naturale Out



Rovere Blanchis Out



Rovere Biondo Out



Rovere Grigio Out



Rovere Bianco Out

Biondo



301613/27 07 ■
Rovere Biondo OUT PEI IV
31x62 7



301605/32 66 ■
Rovere Biondo OUT PEI IV
15,5x62 14

Grigio



301611/27 07 ■
Rovere Grigio OUT PEI IV
31x62 7

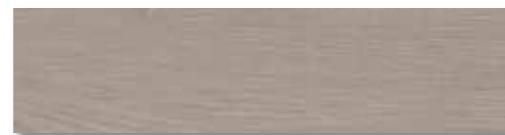

301608/32 66 ■
Rovere Grigio OUT PEI IV
15,5x62 14

Grigio



301610/27 07 ■
Rovere Blanchis OUT PEI IV
31x62 7



301607/32 66 ■
Rovere Blanchis OUT PEI IV
15,5x62 14

Bianco



301609/27 07 ■
Rovere Bianco OUT PEI IV
31x62 7



301604/32 66 ■
Rovere Bianco OUT PEI IV
15,5x62 14

Naturale



301612/27 07 ■
Rovere Naturale OUT PEI IV
31x62 7



301606/32 66 ■
Rovere Naturale OUT PEI IV
15,5x62 14

Schemi di posa / Laying patterns / Schémas de pose / Verlegungsschemen

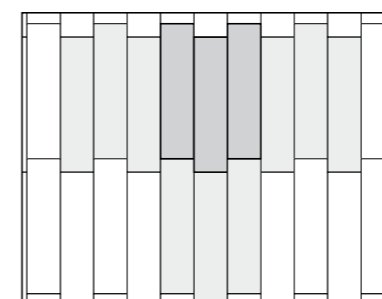

formati sizes	pz / modulo	% / mq	pz / mq
15,5x62	3	100	

Si consiglia di posare il materiale sfalsato di 1/10 (6,2 cm).
We recommend laying the material in a 1/10 (6,2 cm) staggered arrangement.
Il est conseillé de poser le matériau avec un décalage de 1/10 (6,2 cm).
Es wird empfohlen, das Material um 1/10 (6,2 cm) versetzt zu verlegen.

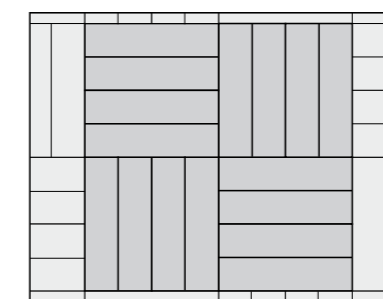

formati sizes	pz / modulo	% / mq	pz / mq
15,5x62	16	100	

Posati con fuga di circa 2 mm.
We recommend a 2 mm joint.
Posés avec un joint d'environ 2 mm.
Mit ungefähr 2 mm breiter Fuge verlegt.

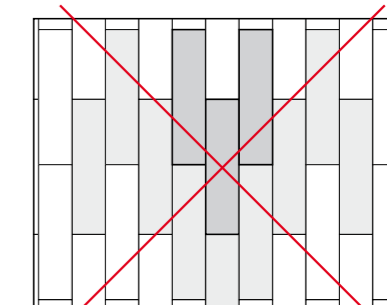

Non è consigliabile posare il materiale sfalsato di 1/2 (31 cm).
We do not recommend laying the material in a 1/2 (31 cm) staggered pattern.
Il est déconseillé de poser le matériau avec un décalage de 1/2 (31 cm).
Es ist nicht empfehlenswert, das Material 1/2 (31 cm) versetzt zu verlegen.

Pezzi speciali

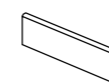

Battiscopa 7,2x62 20 ■
800391/07 Blanchis 22 ■
800169/07 Grigio 22 ■
800166/07 Bianco 22 ■
800165/07 Biondo 22 ■
800390/07 Naturale 22 ■

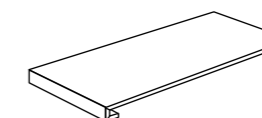

Gradino Frontale 1 ■
31x62/42 85 ■
Naturale

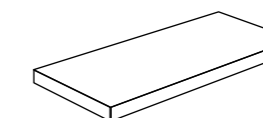

Gradino Angolare 1 ■
DX 31x62/113 71 ■
Naturale
Gradino Angolare 1 ■
SX 31x62/113 71 ■
Naturale

pesi e misure / weight and sizes / poids et mesures / Gewichte und Verpackungen							
dimensioni / sizes / dimensions / abmessungen	spessore / thickness / épaisseur / stärke	pz/collo / pcs/box / pc/boite / stk/ktn	mq/collo / sqm/box / m/boite / qm/ktn	kg/collo / kg/box / kg/boite / kg/ktn	colli/europal / boxes/europal / boites/europal / ktr/europal	mq/europal / sqm/europal / m/europal / qm/europal	kg/europal / kg/europal / kg/europal / kg/europal
Fondo 31x62	9 mm	7	1,35	23,00	60	81	1405
Fondo 15,5x62	9 mm	14	1,35	21,60	40	54	1340



TT0893 Espositore serie Rovere
 cm 60x68x170 1
 Pannelli cm 26x70 7
 Piatrelle 30x60 7
 Peso totale culla + 6 pannelli pastrellati + 6 pannelli piastrellati kg 62

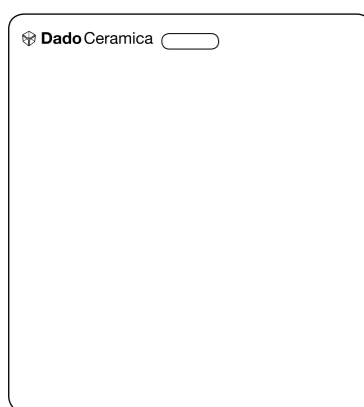

Faesite serie Rovere Out
 cm 62x68



Faesite serie Rovere
 cm 37x98

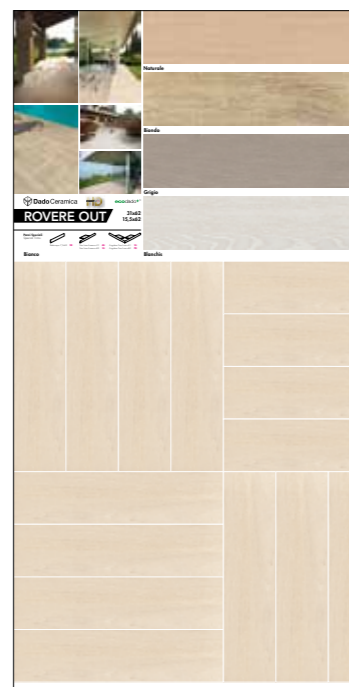

TTP095 Pannello Sinottico serie Rovere Out
 cm 100x200

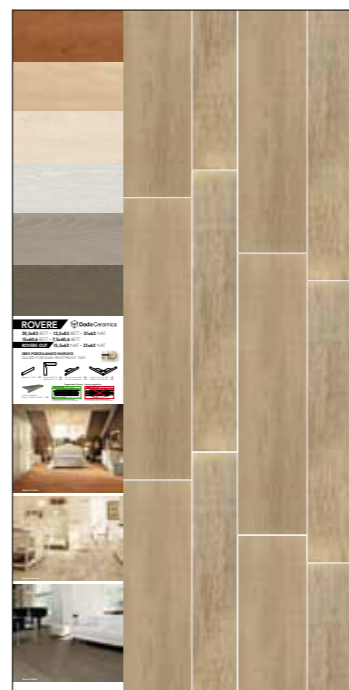

TTP069 Pannello Sinottico serie Rovere
 cm 100x200

note / notes / notes / notes
 Indicare articolo di riferimento per la posa, se diverso da quello in foto
 Indicate article for laying if different from photo / Indiquer article de référence pour la pose s'il est différent de celui sur la photo / Den Bezugsartikel für die Verlegung angeben, falls er von dem im Foto abweicht.

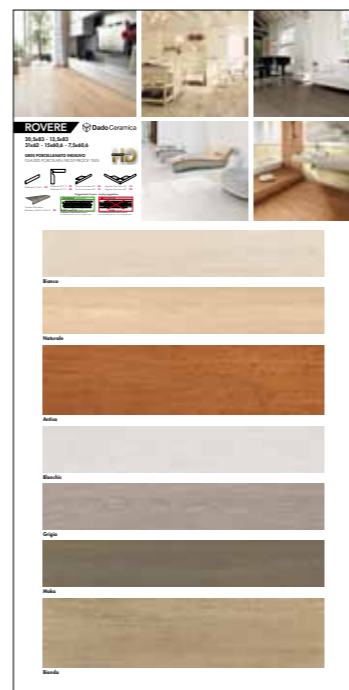

TTP094 Pannello Sinottico Riepilogativo serie Rovere
 cm 100x200



TT0968 Tozzettario serie Rovere
 cm 80x33 aperto - cm 25x33 chiuso

note / notes / notes / notes
 Indicare articolo di riferimento per la posa, se diverso da quello in foto
 Indicate article for laying if different from photo / Indiquer article de référence pour la pose s'il est différent de celui sur la photo / Den Bezugsartikel für die Verlegung angeben, falls er von dem im Foto abweicht.



Prodotto con marcata variazione cromatica.
 High shade texture variation within each carton.
 Produit à variation chromatique accentuée.
 Produkt mit ausgeprägter Farbnuance.

galana

Gres porcellanato ingelivo
 Frost resistant porcelain stoneware
 Grès cérame résistant au gel
 Frostbeständiges Feinsteinzeug

31x31 - 15,5x31 - 15,5x15,5
12"x12" - 6"x12" - 6"x6"



IN R10 PEI IV

Beige

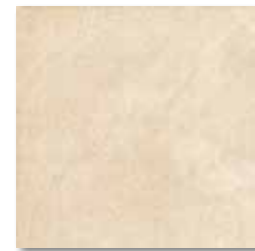
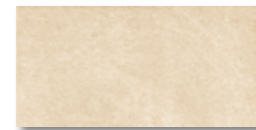
301329/23 48 ■
Galana Beige IN
31x31 14 📦302407/27 46 ■
Galana Beige IN
15,5x31 17 📦302410/31 13 ■
Galana Beige IN
15,5x15,5 34 📦

OUT R12 PEI V

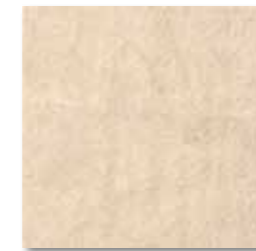
301310/23 48 ■
Galana Beige OUT
31x31 14 📦301313/27 46 ■
Galana Beige OUT
15,5x31 17 📦301334/31 13 ■
Galana Beige OUT
15,5x15,5 34 📦301343/113 71 ■
Mosaico Mattoncino
Galana Beige OUT
15,5x31 (su rete) 23 📦

IN R10 PEI IV

Melange

301330/23 48 ■
Galana Melange IN
31x31 14 📦302408/27 46 ■
Galana Melange IN
15,5x31 17 📦302411/31 13 ■
Galana Melange IN
15,5x15,5 34 📦

OUT R12 PEI V

301311/23 48 ■
Galana Melange OUT
31x31 14 📦301314/27 46 ■
Galana Melange OUT
15,5x31 17 📦301336/31 13 ■
Galana Melange OUT
15,5x15,5 34 📦301344/113 71 ■
Mosaico Mattoncino
Galana Melange OUT
15,5x31 (su rete) 23 📦

Cotto

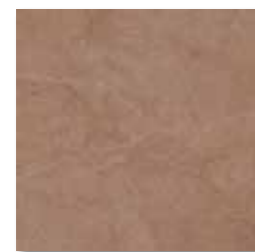
302413/23 48 ■
Galana Cotto IN
31x31 14 📦302418/27 46 ■
Galana Cotto IN
15,5x31 17 📦302419/31 13 ■
Galana Cotto IN
15,5x15,5 34 📦302414/23 48 ■
Galana Cotto OUT
31x31 14 📦302415/27 46 ■
Galana Cotto OUT
15,5x31 17 📦302416/31 13 ■
Galana Cotto OUT
15,5x15,5 34 📦

Grigio

301328/23 48 ■
Galana Grigio IN
31x31 14 📦302409/27 46 ■
Galana Grigio IN
15,5x31 17 📦302412/31 13 ■
Galana Grigio IN
15,5x15,5 34 📦301309/23 48 ■
Galana Grigio OUT
31x31 14 📦301312/27 46 ■
Galana Grigio OUT
15,5x31 17 📦301335/31 13 ■
Galana Grigio OUT
15,5x15,5 34 📦301345/113 71 ■
Mosaico Mattoncino
Galana Grigio OUT
15,5x31 (su rete) 23 📦

Pezzi speciali / Special trims / Pièces spéciales / Spezielle Teile

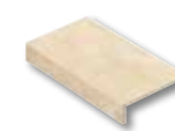
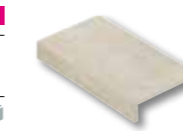
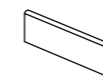
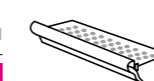
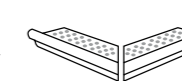
800155/16 51 ■
Elemento a Elle
Galana Beige OUT
31x16,5x6 8 📦800157/16 51 ■
Elemento a Elle
Galana Melange
OUT
31x16,5x6 8 📦800156/16 51 ■
Elemento a Elle
Galana Grigio OUT
31x16,5x6 8 📦800246/16 51 ■
Elemento a Elle
Galana Cotto OUT
31x16,5x6 8 📦Battiscopa 7,5x31 46 📦
800158/04 Galana Beige 47 ■
800247/04 Galana Cotto 47 ■
800160/04 Galana Melange 47 ■
800159/04 Galana Grigio 47 ■Torello 31 8 📦
800844/22 Galana Beige 42 ■
800248/22 Galana Cotto 42 ■
800845/22 Galana Melange 42 ■
800846/22 Galana Grigio 42 ■Torello Angolare 31 4 📦
800840/42 Galana Beige 79 ■
800249/42 Galana Cotto 79 ■
800842/42 Galana Melange 79 ■
800843/42 Galana Grigio 79 ■

pesi e misure / weight and sizes / poids et mesures / Gewichte und Verpackungen

dimensioni sizes dimensions abmessungen	spessore thickness épaisseur stärke	pz/collo pcs/box pc/boite stk/ktn	mq/collo sqm/box m/boite qm/ktn	kg/collo kg/box kg/boite kg/ktn	colli/euopal box/euopal boites/euopal ktn/euopal	mq/euopal sqm/euopal m/euopal qm/euopal	kg/euopal kg/euopal kg/euopal kg/euopal
Fondo 15,5x15,5 IN e OUT	8,5 mm	34	0,81685	13,50	85	69,43225	1167,50
Fondo 15,5x31 IN e OUT	8,5 mm	17	0,81685	13,94	85	69,43225	1205
Fondo 31x31 IN e OUT	8,5 mm	14	1,300	23,00	72	93,60	1686
Mosaico Mattoncino 15,5x31 OUT	8,5 mm	23	1,0663	18,87	36	38,38	679

Schemi di posa / Laying patterns / Schémas de pose / Verlegungsschemen

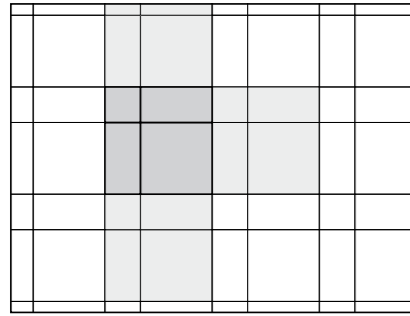

formati sizes	pz / modulo	% / mq	pz / mq
31x31	1	44,4	4,62
15,5x31	2	44,4	9,25
15,5x15,5	1	11,1	4,62

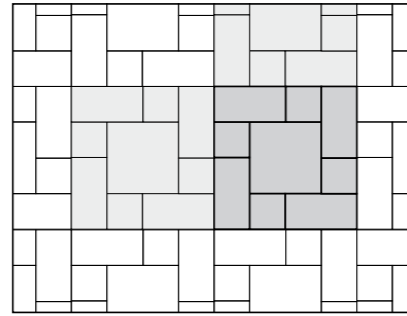

formati sizes	pz / modulo	% / mq	pz / mq
31x31	1	25,0	2,60
15,5x31	4	50,0	10,41
15,5x15,5	4	25,0	10,41

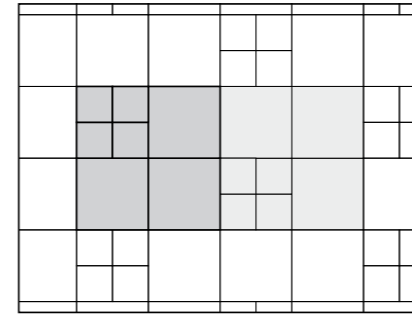

formati sizes	pz / modulo	% / mq	pz / mq
31x31	3	75,0	7,80
15,5x15,5	4	25,0	10,41

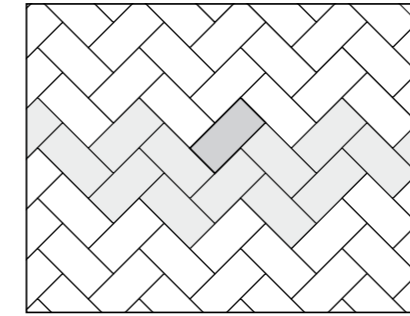

formati sizes	pz / modulo	% / mq	pz / mq
15,5x31	1	100	20,81

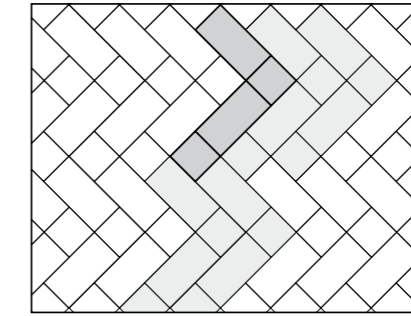

formati sizes	pz / modulo	% / mq	pz / mq
15,5x31	2	66,7	13,87
15,5x15,5	2	33,3	13,87

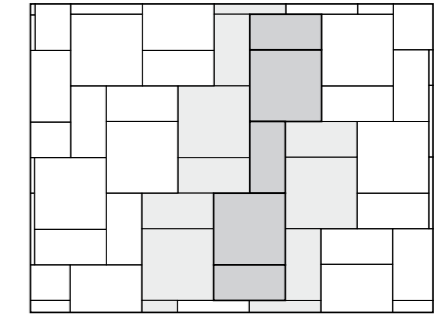

formati sizes	pz / modulo	% / mq	pz / mq
31x31	2	57,1	5,95
15,5x31	3	42,9	8,92

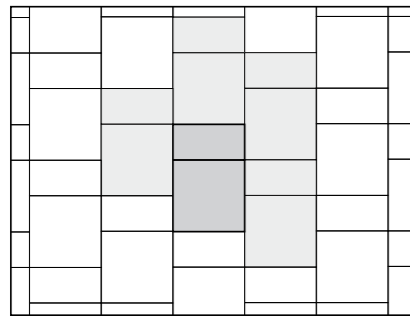

formati sizes	pz / modulo	% / mq	pz / mq
31x31	1	66,7	6,94
15,5x31	1	33,3	6,94

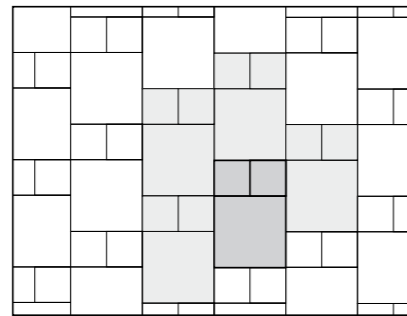

formati sizes	pz / modulo	% / mq	pz / mq
31x31	1	66,7	6,94
15,5x15,5	2	33,3	13,87

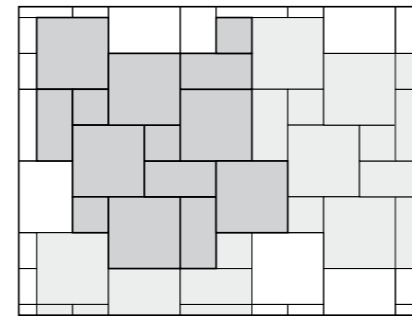

formati sizes	pz / modulo	% / mq	pz / mq
31x31	6	66,7	6,94
15,5x31	4	22,2	4,62
15,5x15,5	4	11,1	4,62

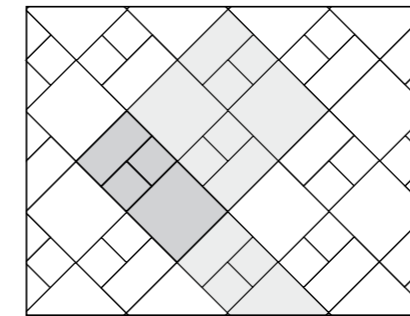

formati sizes	pz / modulo	% / mq	pz / mq
31x31	1	50,0	5,20
15,5x31	1	25,0	5,20
15,5x15,5	2	25,0	10,41

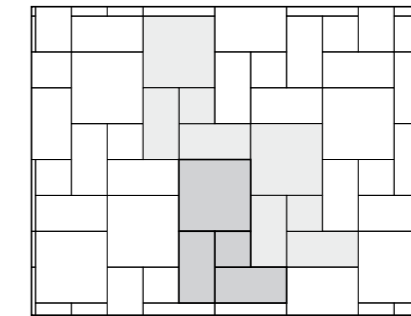

formati sizes	pz / modulo	% / mq	pz / mq
31x31	1	44,4	4,62
15,5x31	2	44,4	9,25
15,5x15,5	1	11,1	4,62

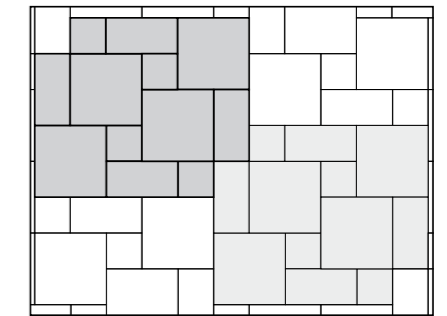

formati sizes	pz / modulo	% / mq	pz / mq
31x31	4	57,1	5,95
15,5x31	4	28,6	5,95
15,5x15,5	4	14,3	5,95

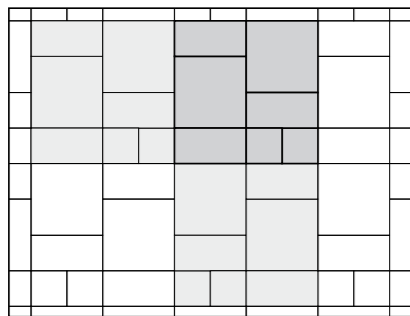

formati sizes	pz / modulo	% / mq	pz / mq
31x31	2	50,0	5,20
15,5x31	3	37,5	7,80
15,5x15,5	2	12,5	5,20

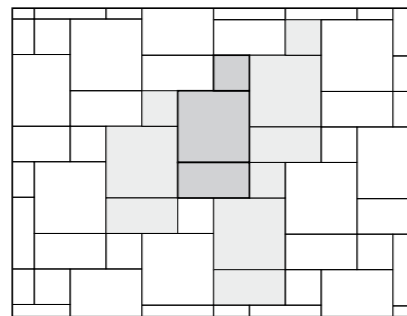

formati sizes	pz / modulo	% / mq	pz / mq
31x31	1	57,1	5,95
15,5x31	1	28,6	5,95
15,5x15,5	1	14,3	5,95

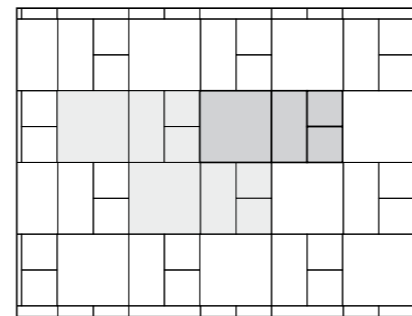

formati sizes	pz / modulo	% / mq	pz / mq
31x31	1	50,0	5,20
15,5x31	1	25,0	5,20
15,5x15,5	2	25,0	10,41

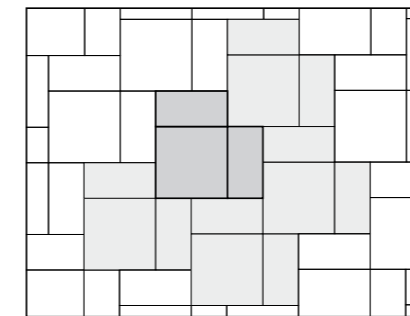

formati sizes	pz / modulo	% / mq	pz / mq
31x31	1	50,0	5,20
15,5x31	2	50,0	10,41



TTP039 Pannello Sinottico
serie Galana Beige
cm 100x200



TTP040 Pannello Sinottico
serie Galana Melange
cm 100x200

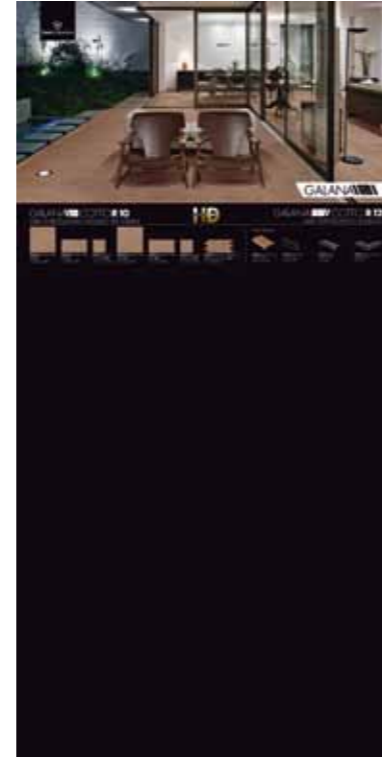

TTP065 Pannello Sinottico
serie Galana Cotto
cm 100x200



TTP041 Pannello Sinottico
serie Galana Grigio
cm 100x200



TTP038 Pannello Sinottico serie Galana
cm 100x200

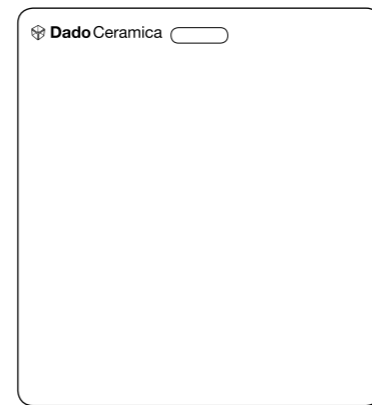

Faesite serie Galana
cm 62x68

wake up

Rivestimento in bicottura
Double-fired wall tiles
Revêtement bicuisson
Zweibrandverfahren Wandfliese

25x75
10"x29,5"

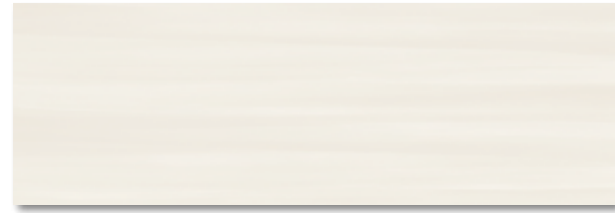
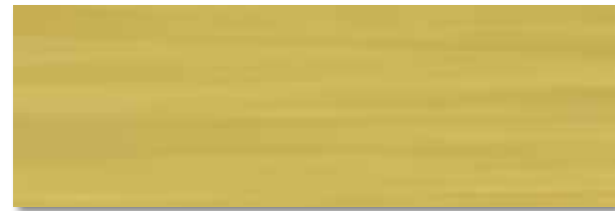

Colori / Colour / Couleurs / Farben

302582/34 61
Wake Bianco
25x75 8302586/37 54
Wake Moka
25x75 8201598/11 33
Bacchetta Wake Moka
3x75 12302583/37 54
Wake Lilla
25x75 8302584/37 54
Wake Arancio
25x75 8201595/11 33
Bacchetta Wake Lilla
3x75 12201596/11 33
Bacchetta Wake Arancio
3x75 12302585/37 54
Wake Senape
25x75 8302587/37 54
Wake Blue
25x75 8201597/11 33
Bacchetta Wake Senape
3x75 12201599/11 33
Bacchetta Wake Blue
3x75 12

pesi e misure / weight and sizes / poids et mesures / Gewichte und Verpackungen

dimensioni sizes dimensions abmessungen	spessore thickness épaisseur stärke	pz/collo pcs/box pc/boite stk/ktn	mq/collo sqm/box m/boite qm/ktn	kg/collo kg/box kg/boite kg/ktn	colli/euopal box/euopal boites/euopal ktn/euopal	mq/euopal sqm/euopal m/euopal qm/euopal	kg/euopal kg/euopal kg/euopal kg/euopal
Fondo Wake 25x75	9,5 mm	8	1,50	24	36	54,00	889

Decori / Decorations / Décorations / Dekors

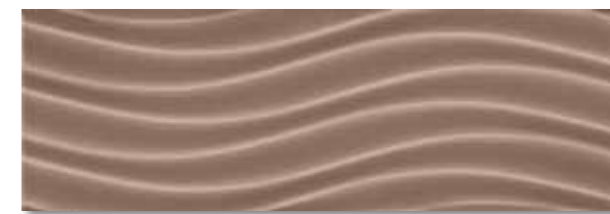
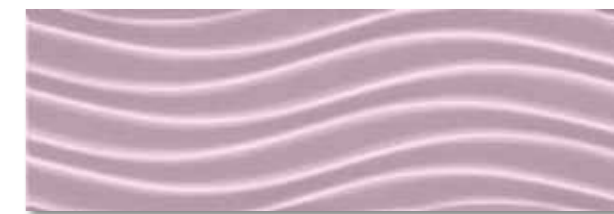
302640/45 76
Onda Wake Bianco
25x75 8302645/45 76
Onda Wake Blue
25x75 8302644/45 76
Onda Wake Moka
25x75 8302641/45 76
Onda Wake Lilla
25x75 8302642/45 76
Onda Wake Arancio
25x75 8302643/45 76
Onda Wake Senape
25x75 8Nuvola Wake 12,5x75 6
001210/14 Bianco 38
001211/14 Moka 38
001212/14 Lilla 38
001213/14 Arancio 38
001214/14 Senape 38
001215/14 Blue 38201603/43 102
Flowers Blue
25x75 4

note / notes / notes / anmerkungen

Pavimenti consigliati vedi serie Rovere pag. 89, 122

Recommended flooring - see Rovere series, page 89, 122 / Revêtements de sol conseillés voir série Rovere page 89, 122 / Empfohlene Bodenbeläge siehe Serie Rovere S. 89, 122

Pavimenti consigliati vedi serie Cementi pag. 13, 123

Recommended flooring - see Cementi series, page 13, 123 / Revêtements de sol conseillés voir série Cementi page 13, 123 / Empfohlene Bodenbeläge siehe Serie Cementi S. 13, 123

Decori / Decorations / Décorations / Dekors



201607/86 (a comp.) 107 ■
Composizione Symbol Arancio (2 pz.)
50x75 2 comp. 📦



201609/86 (a comp.) 107 ■
Composizione Symbol Senape (2 pz.)
50x75 2 comp. 📦



201608/86 (a comp.) 107 ■
Composizione Symbol Blue (2 pz.)
50x75 2 comp. 📦



201618/32 66 ■
Dandy Arancio
25x75 4 📦



201619/32 66 ■
Dandy Blue
25x75 4 📦



201620/32 66 ■
Dandy Senape
25x75 4 📦



201642/40 78 ■
Flirt
25x75 6 📦



201641/31 13 ■
Listelli Flirt (misti)
12x75 4 📦

Decori / Decorations / Décorations / Dekors



201635/70 (a comp.) 101 ■
Composizione Ikebana Blue (2 pz.)
50x75 2 comp. 📦



201636/70 (a comp.) 101 ■
Composizione Ikebana Senape (2 pz.)
50x75 2 comp. 📦



001208/235 (a comp.) 88 ■
Composizione Bluebell (3 pz.)
75x75 1 comp. 📦



201644/40 78 ■
Listelli Bluebell (misti)
4x75 6 📦



201600/61 95 ■
Cosmic Bianco A
25x75 (8 swarovski originali) 4 📦
201611/38 49 ■
Cosmic Bianco B
25x75 4 📦



201602/61 95 ■
Cosmic Moka A
25x75 (8 swarovski originali) 4 📦
201613/38 49 ■
Cosmic Moka B
25x75 4 📦

Fondi / Base tiles / Fonds / Grundfliesen

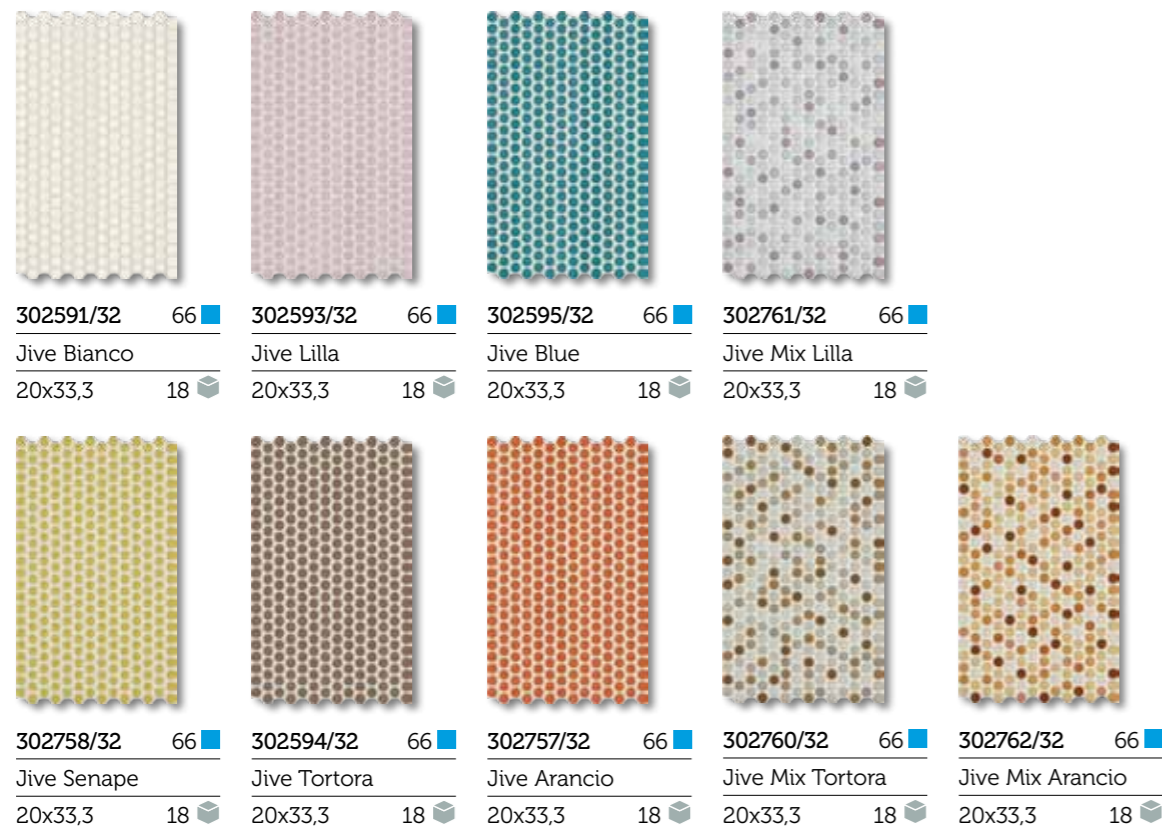

201653/55 97 ■
Profilo in Alluminio anodizzato lucido
1,2x1,2x200 10

201652/40 15 ■
Profilo in Alluminio anodizzato satinato
1,2x1,2x200 10

PROFILO IN ALLUMINIO idoneo ad ospitare il lato della piastrella sagomata con la funzione di coprifilo per l'unione di 2 formati diversi tra loro
Aluminium section suitable for containing the edge of the shaped tile, acting as a cover for joining two different tile sizes / PROFILÉ EN ALLUMINIUM pouvant recevoir le côté profilé du carreau, avec fonction de baguette pour la jonction de 2 formats différents / ALUMINIUMPROFIL, in das die Seitenkante der gerformten Fliese eingefügt werden kann und das als Kantenschutz für die Verbindung von 2 untereinander verschiedenen Formaten dient.

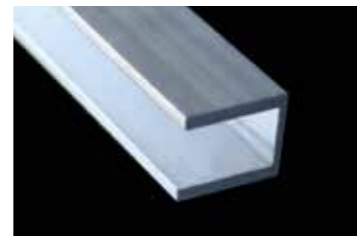

note / notes / notes / anmerkungen

Si consiglia di seguire le istruzioni per l'installazione presenti a pag. 201/206

We recommend to follow the laying instructions at page 201/206 / Il est conseillé de suivre les conseils de pose à la page 201/206 / Um eine korrekte Arbeit zu führen wird es empfohlen auf die Anweisungen der Seite 201/206 zu achten.

pesi e misure / weight and sizes / poids et mesures / Gewichte und Verpackungen

dimensioni sizes dimensions abmessungen	spessore thickness épaisseur stärke	pz/collo pcs/box pc/boite stk/ktn	mq/collo sqm/box m/boite qm/ktn	kg/collo kg/box kg/boite kg/ktn	colli/europal box/europal boites/europal ktn/europal	mq/europal sqm/europal m/europal qm/europal	kg/europal kg/europal kg/europal kg/europal
Fondo Jive 20x33,3	8 mm	18	1,20	14,50	51	61,20	760

Pavimenti consigliati / Recommended flooring / Carreaux pour sol coordonnés / Bodenfliesen-empfehlung

Rovere Gres porcellanato smaltato / Glazed porcelain stoneware / Grès cérame émaillé / Glasiertes Feinsteinzeug

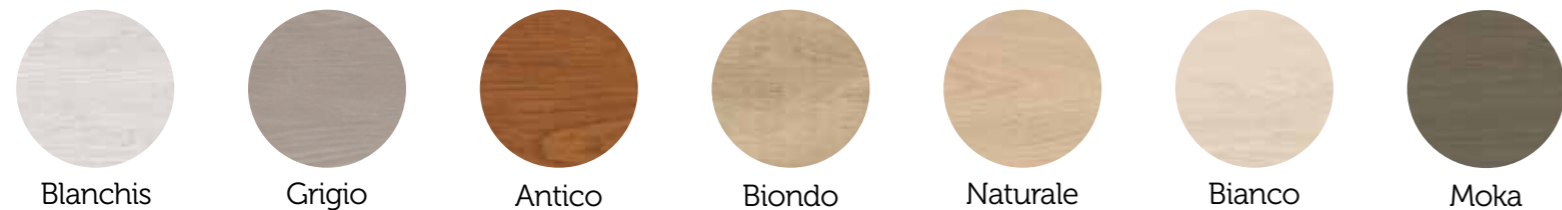

pesi e misure / weight and sizes / poids et mesures / Gewichte und Verpackungen

dimensioni sizes dimensions abmessungen	spessore thickness épaisseur stärke	pz/collo pcs/box pc/boite stk/ktn	mq/collo sqm/box m/boite qm/ktn	kg/collo kg/box kg/boite kg/ktn	colli/europal box/europal boites/europal ktn/europal	mq/europal sqm/europal m/europal qm/europal	kg/europal kg/europal kg/europal kg/europal
Fondo Rovere 75x60,6	9 mm	28	1,273	22,50	40	50,92	915
Fondo Rovere 15x60,6	9 mm	14	1,273	22,50	40	50,92	920
Fondo Rovere 31x62	9 mm	7	1,35	23,00	60	81,00	1405
Fondo Rovere 20,5x83	10 mm	6	1,03	21,95	64	65,92	1420
Fondo Rovere 13,5x83	10 mm	10	1,13	24,08	50	56,50	1220
Mosaico Stuoia 30x30	9 mm	11	1,00	16,50	35	44,10	602
Mosaico Riga 30x60	9 mm	7	1,26	21,50	36	36,00	799

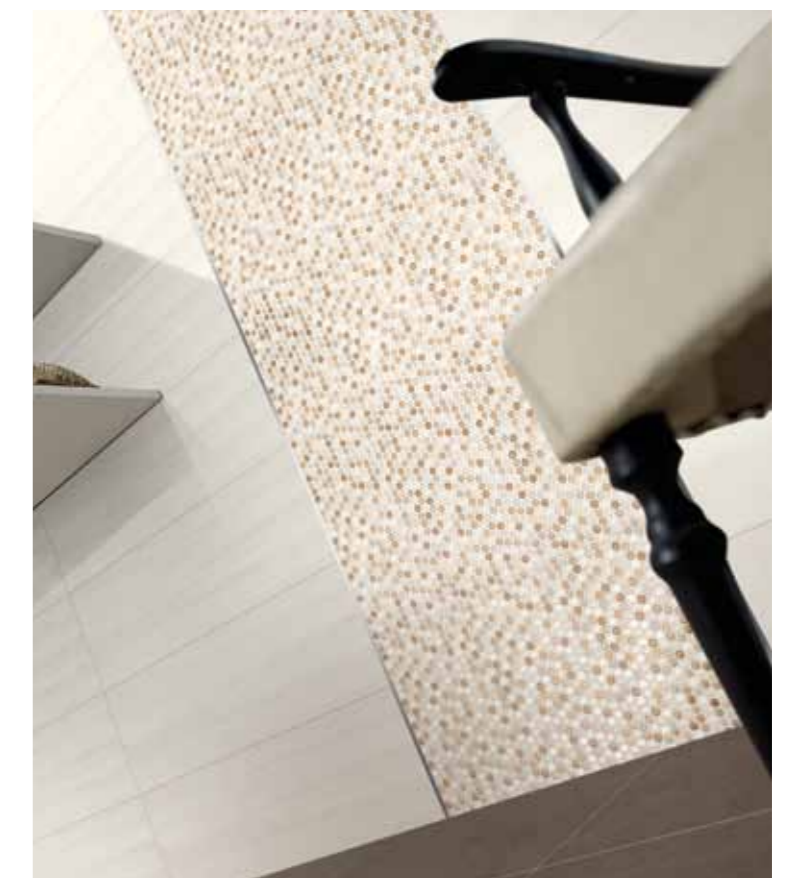

Pavimenti consigliati / Recommended flooring / Carreaux pour sol coordonnés / Bodenfliesen-empfehlung

Cementi Pavimento e Rivestimento in gres porcellanato smaltato rettificato e colorato in massa
Coloured-body rectified, glazed porcelain stoneware wall and floor coverings / Revêtement et sol en grès cérame émaillé rectifié pleine masse / Verkleidung und Fußboden aus glasiertem, geschliffenem, Gefärbte Masse Feinsteinzeug



pesi e misure / weight and sizes / poids et mesures / Gewichte und Verpackungen

dimensioni sizes dimensions abmessungen	spessore thickness épaisseur stärke	pz/collo pcs/box pc/boite stk/ktn	mq/collo sqm/box m/boite qm/ktn	kg/collo kg/box kg/boite kg/ktn	colli/europal box/europal boites/europal ktn/europal	mq/europal sqm/europal m/europal qm/europal	kg/europal kg/europal kg/europal kg/europal
Fondo 62x62 Nat.	9,5 mm	5	1,922	36,20	24	46,128	890
Fondo 60x60 Rett.	9,5 mm	5	1,800	33,90	24	43,20	835
Fondo 30x60 Rett.	9,5 mm	7	1,260	26,25	40	50,40	1120
Fondo 15x60 Rett.	9,5 mm	14	1,260	27,09	40	50,40	1109
Fondo 10x60 Rett.	9,5 mm	16	0,960	20,64	50	48,00	1057
Fondo 5x60 Rett.	9,5 mm	32	0,960	20,64	50	48,00	1057
Fondo 42,5x85 Nat.	10 mm	4	1,445	28,40	48	69,36	1385
Fondo 41,5x83	10 mm	4	1,378	27,08	42	57,88	1160

wake up



TT0960 Espositore Wake up + Perlage

cm 80x115x108 1
Pannelli cm 80x83 12

merchandising



Faesite serie Wake Up

cm 80x83

perlage

125 - 128

perlage

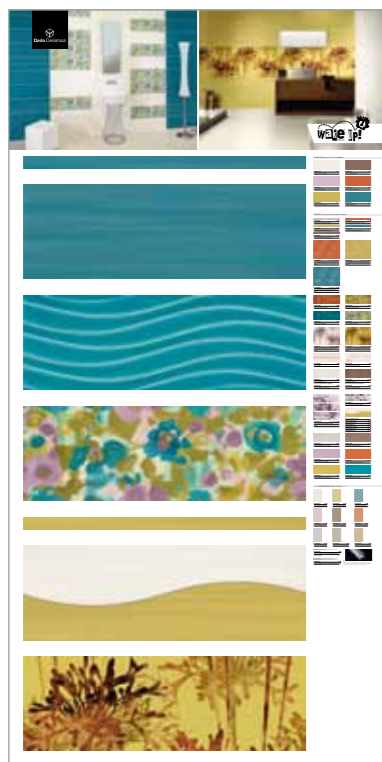

TTP070 Pannello Sinottico
serie Wake Up

cm 100x200

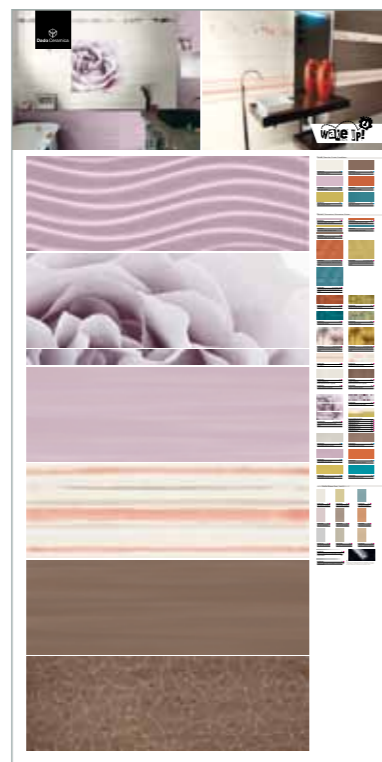

TTP073 Pannello Sinottico
serie Wake Up

cm 100x200

Rivestimento in bicottura
Double-fired wall tiles
Revêtement bicuisson
Zweibrandverfahren Wandfliese

25x75
10"x29,5"

Colori / Colour / Couleurs / Farben

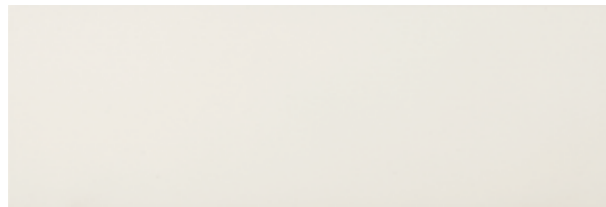

302763/37 54
 Fondo Perlato Bianco
 25x75 8



302764/37 54
 Fondo Perlato Beige
 25x75 8

Decori / Decorations / Décorations / Dekors



302637/43 102
 Onda Perlato Bianco
 25x75 8



302638/43 102
 Onda Perlato Beige
 25x75 8



302639/45 76
 Onda Perlato Antracite
 25x75 8

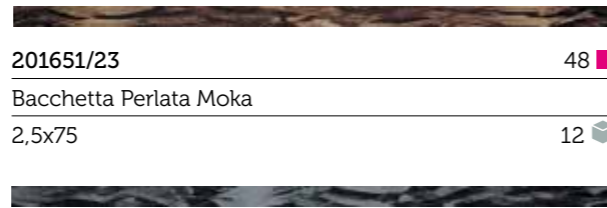

201651/23 48
 Bacchetta Perlata Moka
 2,5x75 12

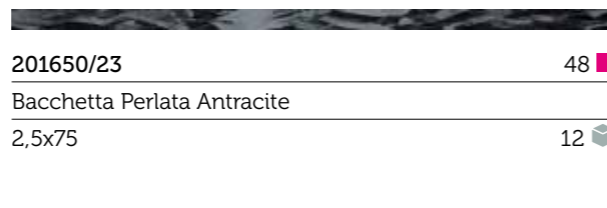

201650/23 48
 Bacchetta Perlata Antracite
 2,5x75 12



note / notes / notes / anmerkungen

Pavimenti consigliati vedi serie Rovere pag. 89

Recommended flooring - see Rovere series, page 89 / Revêtements de sol conseillés voir série Rovere page 89 / Empfohlene Bodenbeläge siehe Serie Rovere S. 89

Pavimenti consigliati vedi serie Cementi pag. 13

Recommended flooring - see Cementi series, page 13 / Revêtements de sol conseillés voir série Cementi page 13 / Empfohlene Bodenbeläge siehe Serie Cementi S. 13

pesi e misure / weight and sizes / poids et mesures / Gewichte und Verpackungen

dimensioni sizes dimensions abmessungen	spessore thickness épaisseur stärke	pz/collo pcs/box pc/boite stk/ktn	mq/collo sqm/box m/boite qm/ktn	kg/collo kg/box kg/boite kg/ktn	colli/europal box/europal boites/europal ktn/europal	mq/europal sqm/europal m/europal qm/europal	kg/europal kg/europal kg/europal kg/europal
Fondo Perlato 25x75	9,5 mm	8	1,50	24	36	54,00	889



TT0960 Espositore Perlage + Wake up
 cm 80x115x108 1
 Pannelli cm 80x83 12

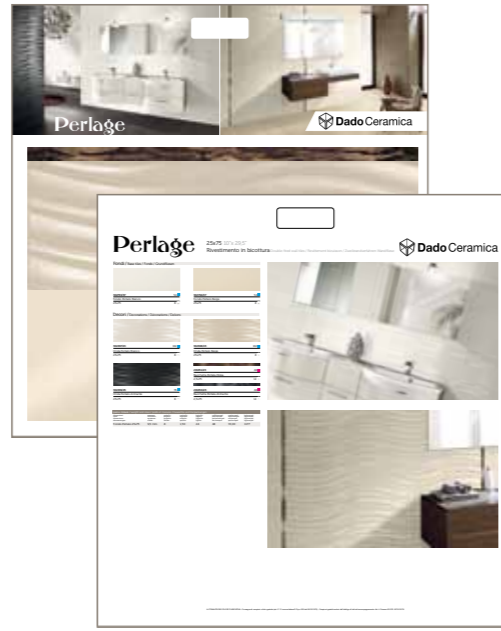

Faesite serie Perlage
 cm 80x83

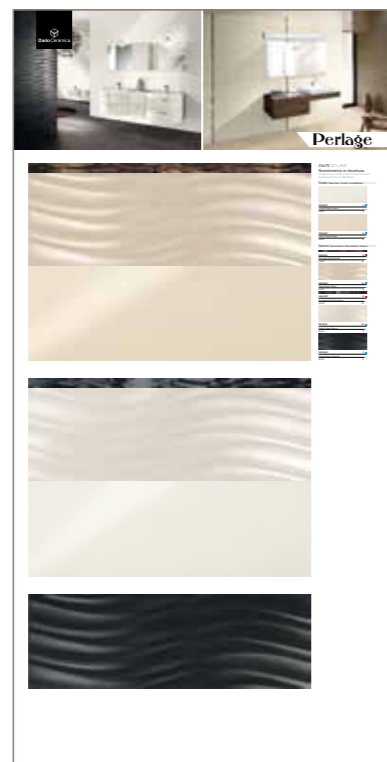

TTP077 Pannello Sinottico serie Perlage
 cm 100x200

i bianchi 25x60

Rivestimento in bicottura
 Double-fired wall tiles
 Revêtement bicuisson
 Zweibrandverfahren Wandfliese

25x60
 10"x24"



White

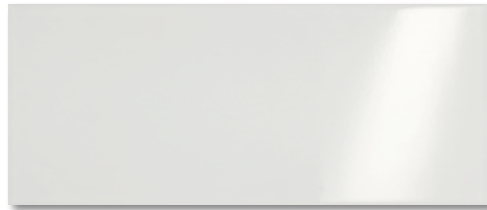

301472/34 61 ■

White 25x60 10



201530/27 46 ■

Soffio A 25x60 4



201538/11 33 ■

Listello Soffio 4,8x60 12



201640/27 46 ■

Tea Break 25x60 6

Light Matt

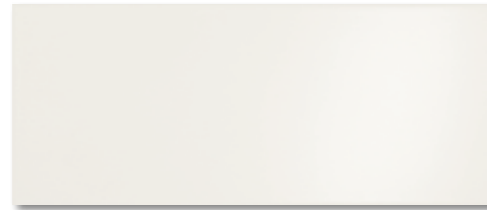

301473/34 61 ■

Light Matt 25x60 10



201531/27 46 ■

Soffio B 25x60 4



201521/08 25 ■

Bacchetta Shade Grey 3x60 18

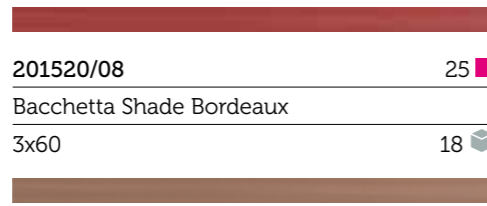

201520/08 25 ■

Bacchetta Shade Bordeaux 3x60 18

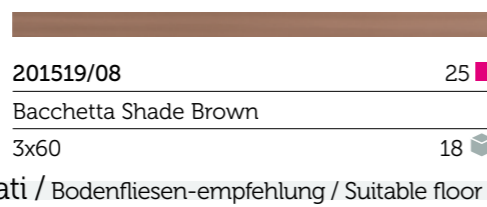

201519/08 25 ■

Bacchetta Shade Brown 3x60 18

Polvere di Stelle



001204/27 91 ■

Polvere di Stelle A 25x60 6



001205/27 91 ■

Polvere di Stelle B 25x60 6



201582/35 96 ■

Listello Polvere di Stelle 3x60 12

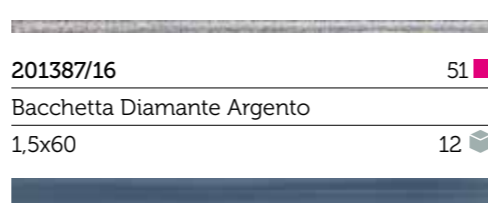

201387/16 51 ■

Bacchetta Diamante Argento 1,5x60 12

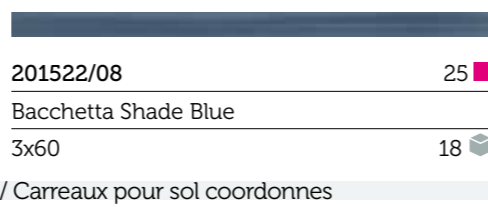

201522/08 25 ■

Bacchetta Shade Blue 3x60 18

Stardust

Rivestimento e pavimento in gres porcellanato smaltato rett. lapp. antiacido e antimacchia
Rectified, lapped, acid-resistant, stain-resistant glazed porcelain stoneware wall and floor tiles / Revêtement et sol en grès cérame émaillé rectifié, rodé, anti-acide, anti-tache / Verkleidung und Boden aus glasiertem Feinsteinzeug, geschliff., geläpft, säurefest, fleckenabweisend



301198/55 97 ■
Star Black Rett. Lapp. PEI III
30x60 7

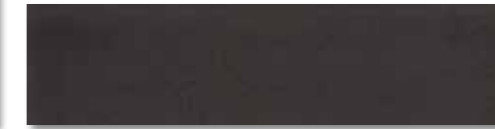

301211/57 94 ■
Star Black Rett. Lapp. PEI III
15x60 14



301236/186 73 ■
Mosaico Star Black 33,3x33,3 (su rete) 9

201411/16 60 ■
Raccordo Star Black 1,5x30 12

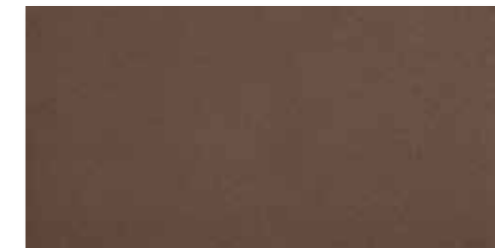

301201/55 97 ■
Star Brown Rett. Lapp. PEI III
30x60 7



301212/57 94 ■
Star Brown Rett. Lapp. PEI III
15x60 14

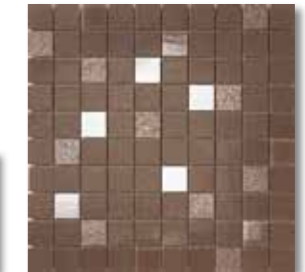

201233/186 73 ■
Mosaico Star Brown 33,3x33,3 (su rete) 9

201409/16 60 ■
Raccordo Star Brown 1,5x30 12



301428/55 97 ■
Star Brown Rett. Lapp. PEI III
44,25x44,25 7



301431/55 97 ■
Star Black Rett. Lapp. PEI III
44,25x44,25 7

301220/57 94 ■
Star Brown Rett. Lapp. PEI III
30x30 14

301219/57 94 ■
Star Black Rett. Lapp. PEI III
30x30 14

note / notes / notes / anmerkungen

Pavimenti consigliati vedi serie Rovere pag. 89
Recommended flooring - see Rovere series, page 89
Revêtements de sol conseillés voir série Rovere page 89
Empfohlene Bodenbeläge siehe Serie Rovere S. 89

Pavimenti consigliati vedi serie Cementi pag. 13
Recommended flooring - see Cementi series, page 13
Revêtements de sol conseillés voir série Cementi page 13
Empfohlene Bodenbeläge siehe Serie Cementi S. 13

Gres Porcellanato Pavimenti consigliati / Bodenfliesen-empfehlung / Suitable floor tiles / Carreaux pour sol coordonnées



R02447/32 66 ■
Corda HR PEI IV
30,5x30,5 14



R02454/32 66 ■
Moka HR PEI IV
30,5x30,5 14



R02453/33 77 ■
Granato HR PEI IV
30,5x30,5 14

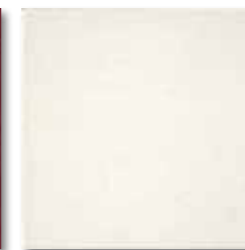

R02446/32 66 ■
Cristallo HR PEI IV
31x31 14



R02442/32 66 ■
Ghisa HR PEI IV
30,5x30,5 14



R02702/32 77 ■
Blu Polveroso HR PEI IV
30,5x30,5 14

pesi e misure / weight and sizes / poids et mesures / Gewichte und Verpackungen								
dimensioni sizes dimensions abmessungen	spessore thickness épaisseur stärke	pz/collo pcs/box pc/boite stk/ktn	mq/collo sqm/box m/boite qm/ktn	kg/collo kg/box kg/boite kg/ktn	colli/europal box/europal boites/europal ktn/europal	mq/europal sqm/europal m/europal qm/europal	kg/europal kg/europal kg/europal kg/europal	
Fondo 25x60	9 mm	10	1,50	23,00	48	72	1130	
Pavimento HR 30,5x30,5	9 mm	14	1,30	23,10	72	93,6	1680	
Pavimento HR 31x31	9 mm	14	1,35	24,00	72	97,20	1750	

pesi e misure / weight and sizes / poids et mesures / Gewichte und Verpackungen								
dimensioni sizes dimensions abmessungen	spessore thickness épaisseur stärke	pz/collo pcs/box pc/boite stk/ktn	mq/collo sqm/box m/boite qm/ktn	kg/collo kg/box kg/boite kg/ktn	colli/europal box/europal boites/europal ktn/europal	mq/europal sqm/europal m/europal qm/europal	kg/europal kg/europal kg/europal kg/europal	
Fondo 15x60	9	14	1,26	24,8	40	50,4	1017	
Fondo 30x60	9	7	1,26	25,1	60	75,6	1531	
Mosaico 33,3x33,3	9	9	1	18,0				
Fondo 30x30	9	14	1,26	24,9	60	76,5	1519	
Fondo 44,25x44,25	9	7	1,3706	25,0	52	71,29	1320	

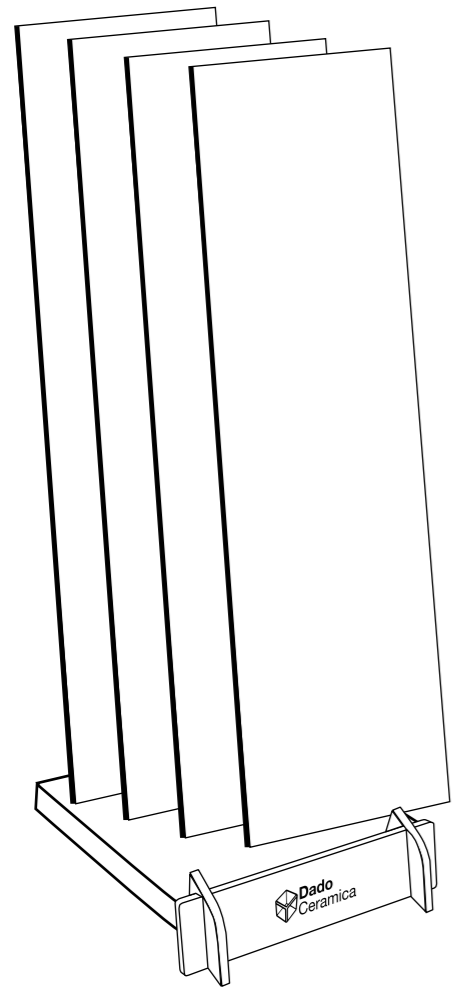

TT0731 Espositore serie I Bianchi 25x60
cm 64x115x160 1
Pannelli cm 64x135 6

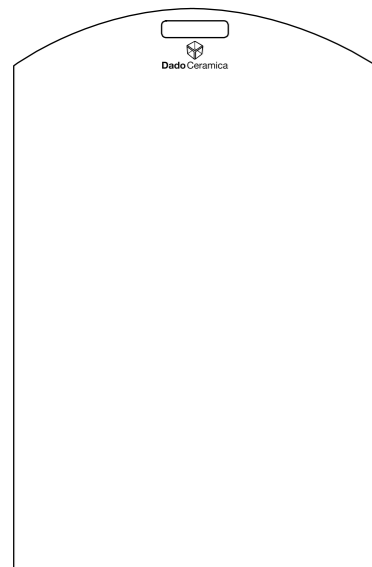

Faesite serie I Bianchi 25x60
cm 65x87

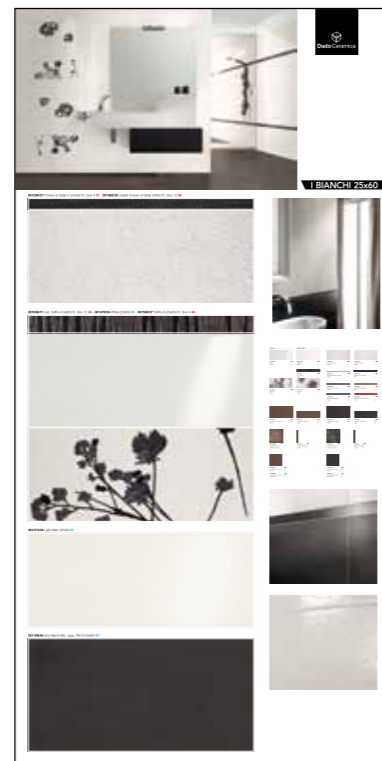

TTP098 Pannello Sinottico serie I Bianchi 25x60
cm 100x200

shade







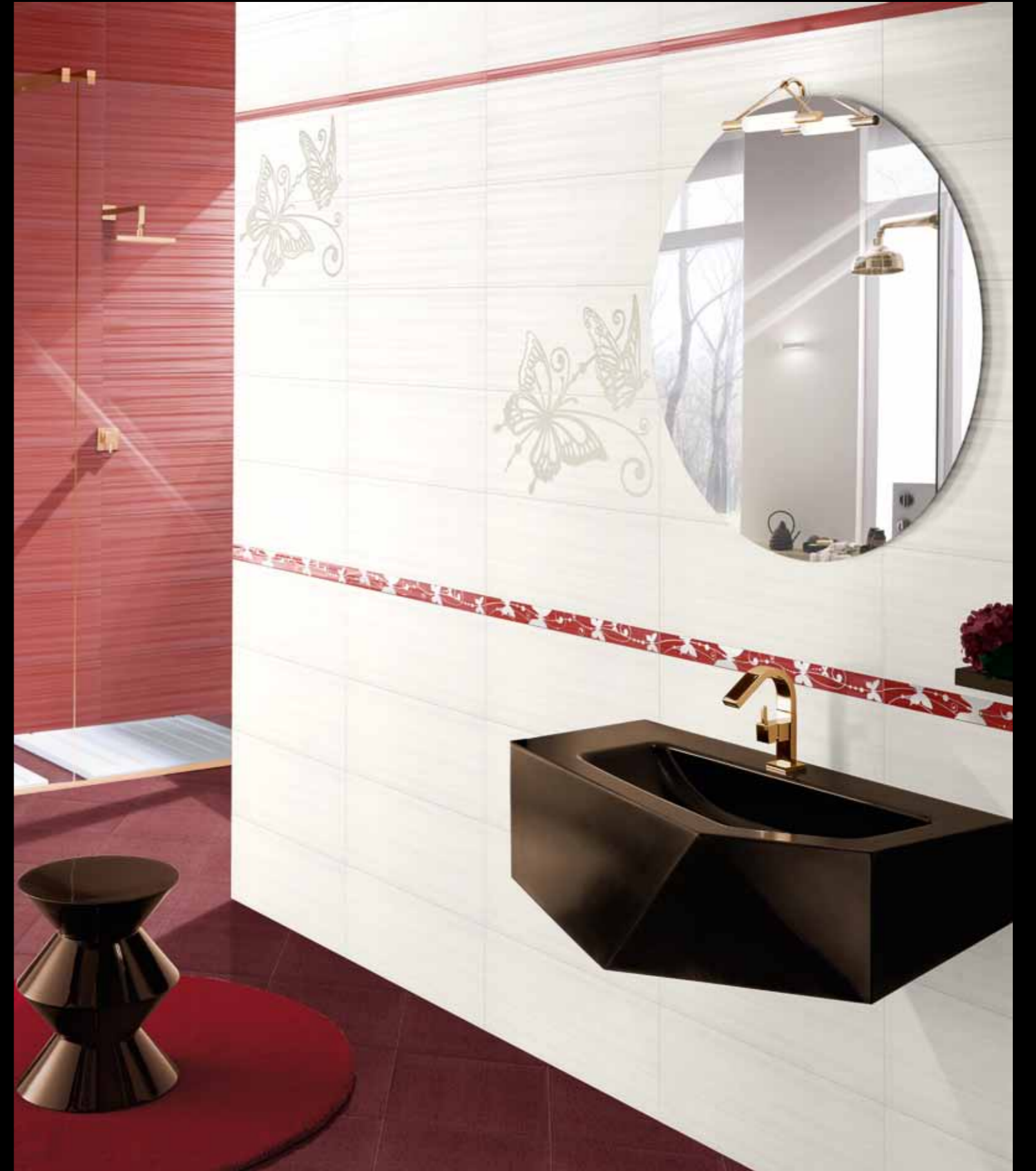

Rivestimento in bicottura
Double-fired wall tiles
Revêtement bicuisson
Zweibrandverfahren Wandfliese

25x60
10"x24"



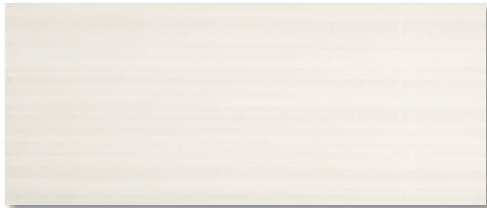

Colori / Colour / Couleurs / Farben





		
302460/37 54 ■	302461/40 15 ■	302462/40 15 ■
Shade Beige	Shade Brown	Shade Bordeaux
25x60 10	25x60 10	25x60 10
		
	201519/08 25 ■	201520/08 25 ■
	Bacchetta Shade Brown	Bacchetta Shade Bordeaux
	3x60 18	3x60 18
		
302459/37 54 ■	302463/40 15 ■	302464/40 15 ■
Shade White	Shade Grey	Shade Blue
25x60 10	25x60 10	25x60 10
		
	201521/08 25 ■	201522/08 25 ■
	Bacchetta Shade Grey	Bacchetta Shade Blue
	3x60 18	3x60 18

Gres Porcellanato Pavimenti consigliati / Bodenfliesen-empfehlung / Suitable floor tiles / Carreaux pour sol coordonnés

					
R02447/32 66 ■	R02454/32 66 ■	R02453/33 77 ■	R02446/32 66 ■	R02442/32 66 ■	R02702/32 77 ■
Corda HR	Moka HR	Granato HR	Cristallo HR	Ghisa HR	Blu Polveroso HR
30,5x30,5 14	30,5x30,5 14	30,5x30,5 14	31x31 14	30,5x30,5 14	30,5x30,5 14

pesi e misure / weight and sizes / poids et mesures / Gewichte und Verpackungen							
dimensioni sizes dimensions abmessungen	spessore thickness épaisseur stärke	pz/collo pcs/box pc/boite stk/ktn	mq/collo sqm/box m/boite qm/ktn	kg/collo kg/box kg/boite kg/ktn	colli/europal box/europal boites/europal ktn/europal	mq/europal sqm/europal m/europal qm/europal	kg/europal kg/europal kg/europal kg/europal
Fondo 25x60	9 mm	10	1,50	23,00	48	72	1130
Pavimento HR 30,5x30,5	9 mm	14	1,30	23,10	72	93,6	1680
Pavimento HR 31x31	9 mm	14	1,35	24,00	72	97,20	1750

Decori / Decorations / Décorations / Dekors

	
001199/485 109 ■	001198/380 110 ■
Composizione Jungle (8 pz.)	Composizione Rosalie (4 pz.)
100x120 1	100x60 1
	
201547/35 62 ■	201548/35 62 ■
Listello Rosalie (misti)	Listello Tulipano (misti)
4x60 6	4x60 6



001200/570 108 ■
Composizione Tulipano (6 pz.)
75x120 1

note / notes / notes / anmerkungen

Pavimenti consigliati vedi serie Rovere pag. 89
Recommended flooring - see Rovere series, page 89 / Revêtements de sol conseillés voir série Rovere page 89 / Empfohlene Bodenbeläge siehe Serie Rovere S. 89

Pavimenti consigliati vedi serie Cementi pag. 13, 143
Recommended flooring - see Cementi series, page 13, 143 / Revêtements de sol conseillés voir série Cementi page 13, 143 / Empfohlene Bodenbeläge siehe Serie Cementi S. 13, 143

Decori / Decorations / Décorations / Dekors



201558/29 10
Funky Tortora
25x60 4



201563/50 80
Ring Brown
25x60 4



001202/91 75
Composizione Mariposa (2 pz.)
50x60 2



201556/27 91
Funky Grey
25x60 4



201566/40 78
Matisse Brown
25x60 4



201568/18 40
Listello Mariposa Bordeaux
4,5x60 6



201559/29 10
Funky Sky
25x60 4



201565/50 80
Ring White
25x60 4



201549/18 40
Listello Mariposa Blue
4,5x60 6



201557/27 91
Funky Blue
25x60 4



201567/40 78
Matisse Blue
25x60 4



200814/20 45
Listello Femme (misti 2 pz.)
5x25 24



Pavimenti consigliati / Recommended flooring / Carreaux pour sol coordonnés / Bodenfliesen-empfehlung

Cementi

Pavimento e Rivestimento in gres porcellanato smaltato rettificato e colorato in massa
Coloured-body rectified, glazed porcelain stoneware wall and floor coverings / Revêtement et sol en grès cérame émaillé rectifié pleine masse / Verkleidung und Fußboden aus glasiertem, geschliffenem, Gefärbte Masse Feinsteinzeug



note / notes / notes / notes

⚡ **Attenzione!! Consultare l'istruzione per la posa contenuta all'interno della scatola del prodotto.**
Please note!! Refer to the installation instructions contained in the product packaging. / Attention!! Consulter le mode d'emploi pour la pose, contenu dans la boîte du produit. / Achtung!! Die Verlegeanleitungen in der Verpackung beachten.

pesi e misure / weight and sizes / poids et mesures / Gewichte und Verpackungen

dimensioni sizes dimensions abmessungen	spessore thickness épaisseur stärke	pz/collo pcs/box pc/boite stk/ktn	mq/collo sqm/box m/boite qm/ktn	kg/collo kg/box kg/boite kg/ktn	colli/europal box/europal boites/europal ktn/europal	mq/europal sqm/europal m/europal qm/europal	kg/europal kg/europal kg/europal kg/europal
Fondo 62x62 Nat.	9,5 mm	5	1,922	36,20	24	46,128	890
Fondo 60x60 Rett.	9,5 mm	5	1,800	33,90	24	43,20	835
Fondo 30x60 Rett.	9,5 mm	7	1,260	26,25	40	50,40	1120
Fondo 15x60 Rett.	9,5 mm	14	1,260	27,09	40	50,40	1109
Fondo 10x60 Rett.	9,5 mm	16	0,960	20,64	50	48,00	1057
Fondo 5x60 Rett.	9,5 mm	32	0,960	20,64	50	48,00	1057
Fondo 42,5x85 Nat.	10 mm	4	1,445	28,40	48	69,36	1385
Fondo 41,5x83	10 mm	4	1,378	27,08	42	57,88	1160



TT0935 Espositore serie Shade

cm 64x115x160

Pannelli cm 64x135

1

6

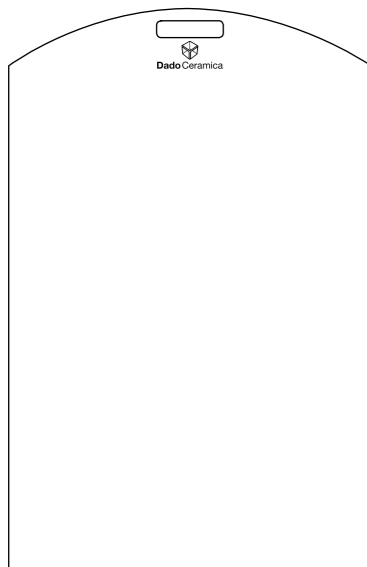

Faesite serie Shade

cm 65x87

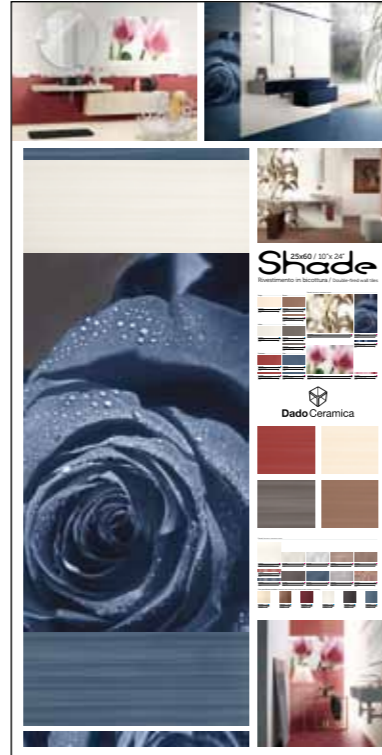

TTP068 Pannello Sinottico Rosalie serie Shade

cm 100x200

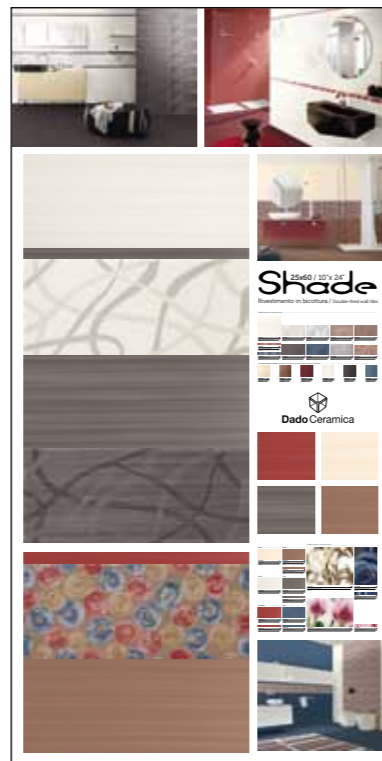

TTP067 Pannello Sinottico serie Shade

cm 100x200

merchandising

145 - 150

silk

Rivestimento in bicottura
 Double-fired wall tiles
 Revêtement bicuisson
 Zweibrandverfahren Wandfliese

20x50
 8"x20"



Beige



301050/37 54 ■

Silk Beige

20x50 11 📦



000996/25 04 ■

Jasmine Beige

20x50 6 📦



301078/186 73 ■

Mosaico Silk Beige

33,3x33,3 (su rete) 9 📦

Bianco



301049/37 54 ■

Silk Bianco

20x50 11 📦



000995/25 04 ■

Jasmine Bianco

20x50 6 📦



301077/186 73 ■

Mosaico Silk Bianco

33,3x33,3 (su rete) 9 📦

Grigio



301070/37 54 ■

Silk Grigio

20x50 11 📦



000999/25 04 ■

Jasmine Grigio

20x50 6 📦

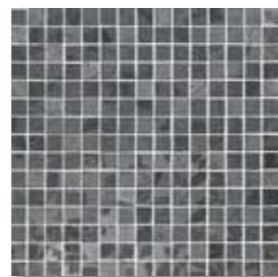

301081/186 73 ■

Mosaico Silk Grigio

33,3x33,3 (su rete) 9 📦

Verde



301052/37 54 ■

Silk Verde

20x50 11 📦



000997/25 04 ■

Jasmine Verde

20x50 6 📦



301080/186 73 ■

Mosaico Silk Verde

33,3x33,3 (su rete) 9 📦

Rosa



301051/37 54 ■

Silk Rosa

20x50 11 📦



000998/25 04 ■

Jasmine Rosa

20x50 6 📦



301079/186 73 ■

Mosaico Silk Rosa

33,3x33,3 (su rete) 9 📦

Gres Porcellanato Pavimenti consigliati / Suitable floor tiles / Carreaux pour sol coordonnés / Bodenfliesen-empfehlung



R02447/32 66 ■

Corda HR PEI IV

30,5x30,5 14 📦



R02454/32 66 ■

Moka HR PEI IV

30,5x30,5 14 📦

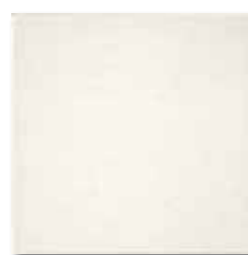

R02446/32 66 ■

Cristallo HR PEI IV

31x31 14 📦



R02400/33 ● 77 ■

Nero HR PEI III

25x25 18 📦



R02445/32 66 ■

Grigio HR PEI IV

30,5x30,5 14 📦



R01944/32 ● 66 ■

Muschio HR PEI IV

25x25 18 📦



R02440/32 66 ■

Fluxia HR PEI IV

30,5x30,5 14 📦

Decori / Decorations
Décorations / Dekors



001093/38 49 ■

D. Silk Silver

20x50 6 📦



001092/38 49 ■

D. Silk Gold

20x50 6 📦

Bacchette / Liners
Baguettes / Leisten



201287/22 42 ■

Bacchetta Kromia Beige 2x50 12 📦



201270/18 41 ■

Bacchetta Silk Beige 3x50 12 📦



201286/22 42 ■

Bacchetta Kromia Bianca 2x50 12 📦



201269/18 41 ■

Bacchetta Silk Bianco 3x50 12 📦



201290/22 42 ■

Bacchetta Kromia Metal 2x50 12 📦



201279/18 41 ■

Bacchetta Silk Grigio 3x50 12 📦



201288/22 42 ■

Bacchetta Kromia Verde 2x50 12 📦



201273/18 41 ■

Bacchetta Silk Verde 3x50 12 📦



201289/22 42 ■

Bacchetta Kromia Rosa 2x50 12 📦



201271/18 41 ■

Bacchetta Silk Rosa 3x50 12 📦



201446/20 45 ■

Bacchetta Silk Silver 3x50 12 📦



201445/20 45 ■

Bacchetta Silk Gold 3x50 12 📦

note / notes / notes / anmerkungen

● Ad esaurimento verrà prodotto nel formato 31x31
Will be produced in the 31x31 size while stocks last / En cas d'épuisement, il sera produit dans le format 31x31 / Restbestand, wird in Zukunft im Format 31x31 hergestellt

pesi e misure / weight and sizes / poids et mesures / Gewichte und Verpackungen

dimensioni sizes dimensions abmessungen	spessore thickness épaisseur stärke	pz/collo pcs/box pc/boite stk/ktn	mq/collo sqm/box m/boite qm/ktn	kg/collo kg/box kg/boite kg/ktn	colli/europal box/europal boites/europal ktn/europal	mq/europal sqm/europal m/europal qm/europal	kg/europal kg/europal kg/europal kg/europal
Fondo 20x50	9 mm	11	1,10	16	64	70,4	1040
Mosaico 33,3x33,3	9 mm	9	1	12			
Pavimento HR 25x25	9 mm	18	1,125	21,30	80	90	1710
Pavimento HR 30,5x30,5	9 mm	14	1,30	23,10	72	93,6	1680
Pavimento HR 31x31	9 mm	14	1,35	24,00	72	97,20	1750



TT0731 Espositore serie Silk

cm 52x115x160	1
Pannelli cm 52x135	6



TTP022 Pannello Sinottico serie Silk
cm 100x200

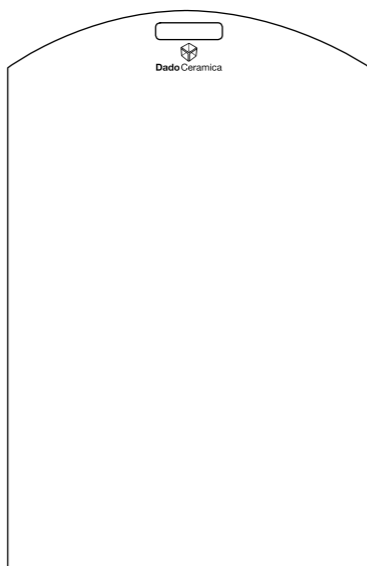

Faesite serie Silk
cm 55x87

preziosa

Rivestimento in bicottura
 Double-fired wall tiles
 Revêtement bicuisson
 Zweibrandverfahren Wandfliese

20x50
 8"x20"



Colori / Colour / Couleurs / Farben

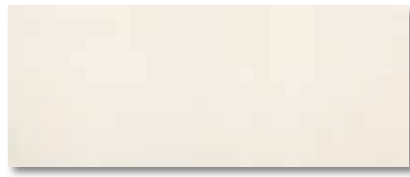

300935/33 77 ■
Vip Avorio 11 📦
20x50



300936/37 54 ■
Vip Beige 11 📦
20x50



300937/37 54 ■
Vip Caffè 11 📦
20x50



201325/13 37 ■
Velvet Avorio 6 📦
20x50



201239/42 85 ■
Extreme 6 📦
20x50



201295/25 04 ■
List. Velvet Caffè 12 📦
6,5x50



302785/32 ★ 66 ■
Lambada Mix Moka 18 📦
20x33,3

Colori / Colour / Couleurs / Farben



300932/33 77 ■
Vip Perla 11 📦
20x50



201324/13 37 ■
Velvet Perla 6 📦
20x50



201294/25 04 ■
List. Velvet Antracite 12 📦
6,5x50



302772/32 ★ 66 ■
Lambada Mix Grey 18 📦
20x33,3



300933/37 54 ■
Vip Grigio 11 📦
20x50



201241/70 89 ■
Energy Grigio 6 📦
20x50



201240/40 78 ■
Metal 6 📦
20x50

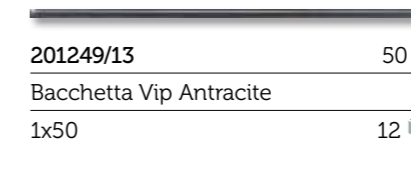

201249/13 50 ■
Bacchetta Vip Antracite 12 📦
1x50

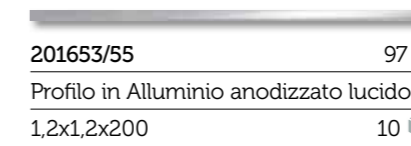

201653/55 97 ■
Profilo in Alluminio anodizzato lucido 10 📦
1,2x1,2x200



300934/37 54 ■
Vip Antracite 11 📦
20x50

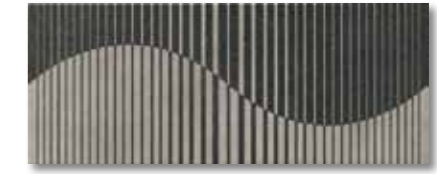

201242/70 89 ■
Energy Antracite 6 📦
20x50



201254/42 85 ■
Extreme Antracite 6 📦
20x50

Gres Porcellanato Pavimenti consigliati / Suitable floor tiles / Carreaux pour sol coordonnés / Bodenfliesen-empfehlung



R02447/32 66 ■
Corda HR PEI IV 14 📦
30,5x30,5



R02454/32 66 ■
Moka HR PEI IV 14 📦
30,5x30,5



R02442/32 66 ■
Ghisa HR PEI IV 14 📦
30,5x30,5

pesi e misure / weight and sizes / poids et mesures / Gewichte und Verpackungen							
dimensioni sizes dimensions abmessungen	spessore thickness épaisseur stärke	pz/collo pcs/box pc/boite stk/ktn	mq/collo sqm/box m/boite qm/ktn	kg/collo kg/box kg/boite kg/ktn	colli/euopal box/euopal boites/euopal ktn/euopal	mq/euopal sqm/euopal m/euopal qm/euopal	kg/euopal kg/euopal kg/euopal kg/euopal
Fondo 20x50	9 mm	11	1,10	16	64	70,4	1040
Fondo Lambada 20x33,3	8 mm	18	1,20	14,50	51	61,20	760
Pavimento HR 30,5x30,5	9 mm	14	1,30	23,10	72	93,6	1680

note / notes / notes / anmerkungen

★ Si consiglia di seguire le istruzioni per l'installazione presenti a pag. 201/206
We recommend to follow the laying instructions at page 201/206 / Il est conseillé de suivre les conseils de pose à la page 201/206 / Um eine korrekte Arbeit zu führen wird es empfohlen auf die Anweisungen der Seite 201/206 zu achten.

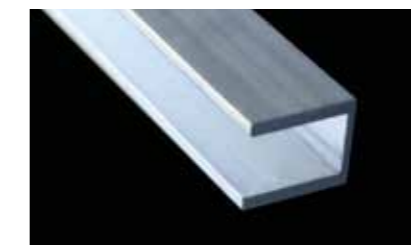

PROFILO IN ALLUMINIO idoneo ad ospitare il lato della piastrella sagomata con la funzione di coprifilo per l'unione di 2 formati diversi tra loro
Aluminium section suitable for containing the edge of the shaped tile, acting as a cover for joining two different tile sizes / PROFILÉ EN ALUMINIUM pouvant recevoir le côté profilé du carreau, avec fonction de baguette pour la jonction de 2 formats différents / ALUMINIUMPROFIL, in das die Seitenkante der geformten Fliese eingefügt werden kann und das als Kantenschutz für die Verbindung von 2 untereinander verschiedenen Formaten dient.



TT0731 Espositore serie Preziosa

cm 52x115x160	1
Pannelli cm 52x135	6

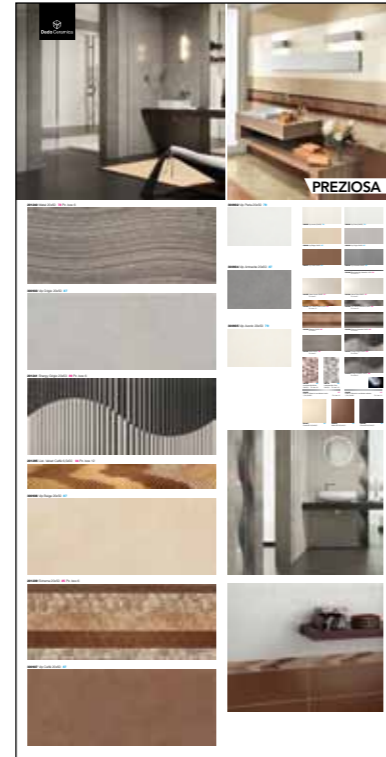

TTP022 Pannello Sinottico serie Preziosa
cm 100x200



Faesite serie Preziosa
cm 55x87

kolora

Rivestimento in bicottura
Double-fired wall tiles
Revêtement bicuisson
Zweibrandverfahren Wandfliese

20x50
8"x20"





Colori / Colour / Couleurs / Farben



300939/33 77
Joy Bianco
20x50 11



201213/132 90
Luxury Bianco
20x50 10

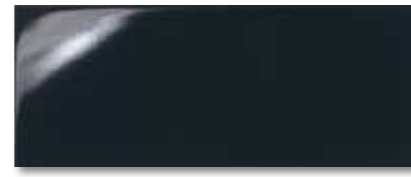

300938/37 54
Joy Nero
20x50 11



201639/22 42
Bonjour A
20x50 6



201216/40 15
Elegance
20x50 6

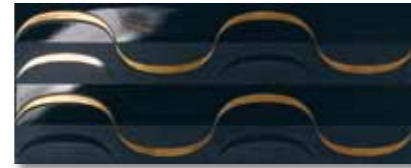

201217/42 85
Elegance Black
20x50 6



201649/22 42
Bonjour B
20x50 6



201326/14 38
Stream
20x50 6

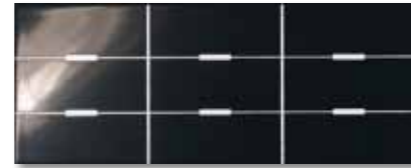

201224/235 88
Nickel
20x50 10



201230/12 35
Bacchetta Joy Nero
2x50 12



201220/25 04
List. Nickel
4,5x50 12

Gres Porcellanato Pavimenti consigliati / Suitable floor tiles / Carreaux pour sol coordonnés / Bodenfliesen-empfehlung

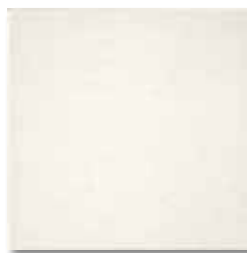

R02446/32 66
Cristallo HR PEI IV
31x31 14



R02400/33 77
Nero HR PEI III
25x25 18



R02456/40 15
Karmin HR PEI III
31x31 18

pesi e misure / weight and sizes / poids et mesures / Gewichte und Verpackungen							
dimensioni sizes dimensions abmessungen	spessore thickness épaisseur stärke	pz/collo pcs/box pc/boite stk/ktn	mq/collo sqm/box m/boite qm/ktn	kg/collo kg/box kg/boite kg/ktn	colli/europal box/europal boites/europal ktn/europal	mq/europal sqm/europal m/europal qm/europal	kg/europal kg/europal kg/europal kg/europal
Fondo 20x50	9 mm	11	1,10	16	64	70,4	1040
Fondo 20x33,3	8 mm	18	1,20	14,50	51	61,20	760
Pavimento HR 25x25	9 mm	18	1,125	21,30	80	90	1710
Pavimento HR 31x31	9 mm	14	1,35	24,00	72	97,20	1750

Colori / Colour / Couleurs / Farben



201584/16 51
Arcobaleno Nero
20x50 4



300940/37 54
Joy Rosso
20x50 11



201583/16 51
Arcobaleno Giallo
20x50 4



201587/16 51
Corolle Nero
20x50 4



201214/136 67
Luxury Rosso
20x50 10



302699/35 96
Reggaeton Nero
20x33,3 18

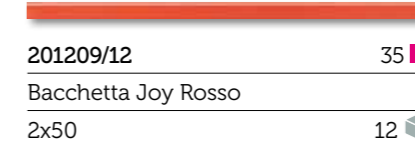

201209/12 35
Bacchetta Joy Rosso
2x50 12



302697/32 66
Reggaeton Giallo
20x33,3 18



201211/16 51
Bacchetta Elegance
2,5x50 12



201223/27 46
Penny Black
20x50 6



note / notes / notes / anmerkungen

- * Questi prodotti potrebbero presentare la caratteristica puntinatura del rosso al selenio.
These products may present the typical red-colour dots obtained from Selenium / Ces produits pourraient présenter la piqure caractéristique du rouge de sélénium / Diese Produkte könnten die typischen roten Selenium-Farbkörner aufweise
- Ad esaurimento verrà prodotto nel formato 31x31
Will be produced in the 31x31 size while stocks last / En cas d'épuisement, il sera produit dans le format 31x31 / Restbestand, wird in Zukunft im Format 31x31 hergestellt

Colori / Colour / Couleurs / Farben



300941/37 54 ■
Joy Giallo
20x50 11 ☞



201219/32 66 ■
Clips Giallo
20x50 6 ☞



201212/12 35 ■
Bacchetta Joy Giallo
2x50 12 ☞



201314/45 76 ■
Naif (misto 3 pz.)
20x50 6 ☞



201255/113 71 ■
Prince Lilla
20x50 4 ☞



201258/47 86 ■
List. Prince Lilla
4x50 12 ☞



201327/14 38 ■
Steel
20x50 6 ☞



201296/40 15 ■
List Sky Celeste
9,5x50 12 ☞



201588/16 51 ■
Corolle Celeste
20x50 4 ☞



201588/16 51 ■
Corolle Celeste
20x50 4 ☞

Colori / Colour / Couleurs / Farben



300943/37 54 ■
Joy Celeste
20x50 11 ☞



201215/35 62 ■
Eternity Celeste
20x50 6 ☞



201208/12 35 ■
Bacchetta Joy Celeste
2x50 12 ☞



201234/15 39 ■
Tozz. Glamour C
20x20 18 ☞



300944/37 54 ■
Joy Verde
20x50 11 ☞



201218/32 66 ■
Clips Celeste
20x50 6 ☞



201210/12 35 ■
Bacchetta Joy Verde
2x50 12 ☞



302698/32 66 ■
Reggaeton Verde
20x33,3 18 ☞



302581/37 54 ■
Joy Lilla
20x50 11 ☞



201585/16 51 ■
Arcobaleno Lilla
20x50 4 ☞



201634/12 35 ■
Bacchetta Joy Lilla
2x50 12 ☞



201610/16 51 ■
Corolle Lilla
20x50 4 ☞

Gres Porcellanato Pavimenti consigliati / Suitable floor tiles / Carreaux pour sol coordonnés / Bodenfliesen-empfehlung



R02449/33 77 ■
Soleado HR PEI IV
30,5x30,5 14 ☞



R02456/40 ★ 15 ■
Karmin HR PEI III
31x31 18 ☞

note / notes / notes / anmerkungen

★ Questi prodotti potrebbero presentare la caratteristica puntinatura del rosso al selenio.
These products may present the typical red-colour dots obtained from Selenium / Ces produits pourraient présenter la piqûre caractéristique du rouge de sélénium / Diese Produkte könnten die typischen roten Selenium-Farbkörner aufweisen

● Ad esaurimento verrà prodotto nel formato 31x31
Will be produced in the 31x31 size while stocks last / En cas d'épuisement, il sera produit dans le format 31x31 / Restbestand, wird in Zukunft im Format 31x31 hergestellt

pesi e misure / weight and sizes / poids et mesures / Gewichte und Verpackungen

dimensioni sizes dimensions abmessungen	spessore thickness épaisseur stärke	pz/collo pcs/box pc/boite stk/ktn	mq/collo sqm/box m/boite qm/ktn	kg/collo kg/box kg/boite kg/ktn	colli/europal box/europal boites/europal ktr/europal	mq/europal sqm/europal m/europal qm/europal	kg/europal kg/europal kg/europal kg/europal
Fondo 20x50	9 mm	11	1,10	16	64	70,4	1040
Fondo 20x33,3	8 mm	18	1,20	14,50	51	61,20	760
Pavimento HR 25x25	9 mm	18	1,125	21,30	80	90	1710

Gres Porcellanato Pavimenti consigliati / Suitable floor tiles / Carreaux pour sol coordonnés / Bodenfliesen-empfehlung



301618/32 66 ■
Turchese HR PEI IV
33,3x33,3 14 ☞



R01944/32 ● 66 ■
Muschio HR PEI IV
25x25 18 ☞



301617/32 66 ■
Lilla HR PEI IV
33,3x33,3 14 ☞

pesi e misure / weight and sizes / poids et mesures / Gewichte und Verpackungen

dimensioni sizes dimensions abmessungen	spessore thickness épaisseur stärke	pz/collo pcs/box pc/boite stk/ktn	mq/collo sqm/box m/boite qm/ktn	kg/collo kg/box kg/boite kg/ktn	colli/europal box/europal boites/europal ktr/europal	mq/europal sqm/europal m/europal qm/europal	kg/europal kg/europal kg/europal kg/europal
Pavimento HR 30,5x30,5	9 mm	14	1,30	23,10	72	93,6	1680
Pavimento HR 31x31	9 mm	14	1,35	24,00	72	97,20	1750
Pavimento HR 33,3x33,3	9 mm	14	1,55	28,50	48	74,40	1372



TT0732 Espositore serie Kolora

TT0955 Espositore serie Kolora Novità

cm 52x115x160

1

Pannelli cm 52x135

6

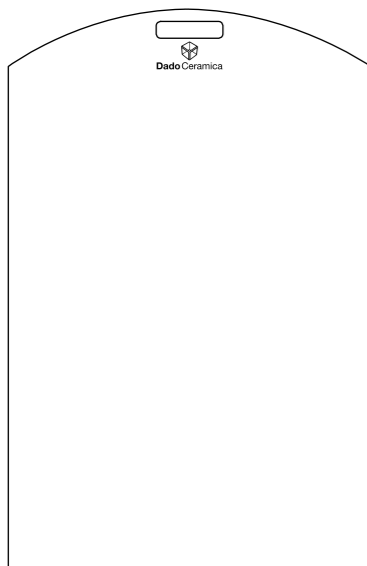

Faesite serie Kolora

cm 55x87

merchandising

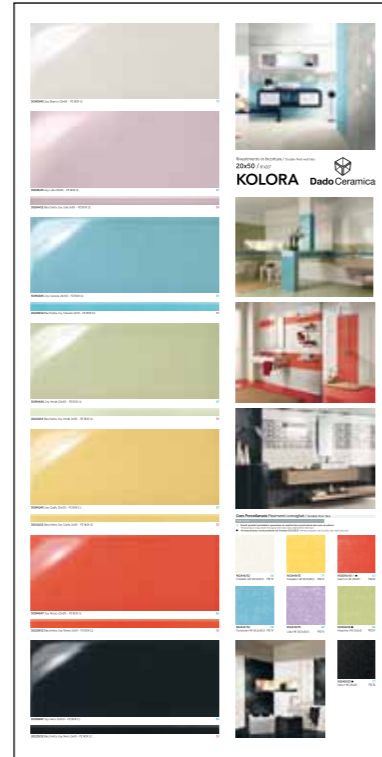

TTP019 Pannello Sinottico Riepilogativo serie Kolora

cm 100x200

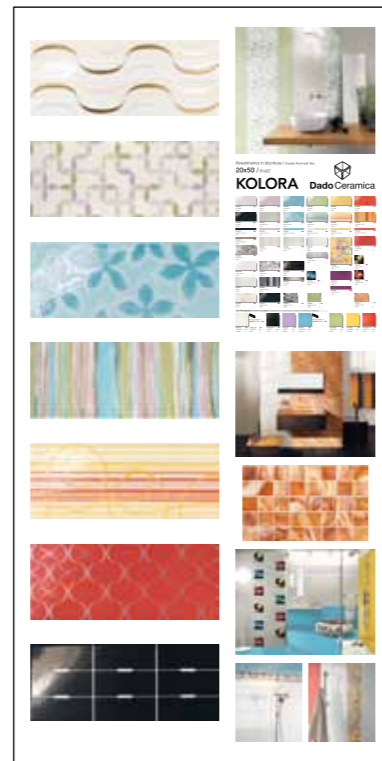

TTP083 Pannello Sinottico serie Kolora

cm 100x200

city

Rivestimento in bicottura
Double-fired wall tiles
Revêtement bicuisson
Zweibrandverfahren Wandfliese

20x50
8"x20"

Colori / Colour / Couleurs / Farben



301045/33 77 ■
 City Bianco
 20x50 11



301046/33 77 ■
 City Matt Bianco
 20x50 11



201305/27 91 ■
 Amber Grigio
 20x50 6



201340/16 51 ■
 Bacc. Napel Grigio
 2,5x50 12

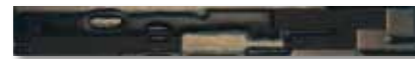

201339/29 10 ■
 List. Etnic Grigio
 6x50 12



201307/12 36 ■
 List. Amber Grigio
 4,5x50 12



301047/33 77 ■
 City Beige
 20x50 11



301048/33 77 ■
 City Matt Beige
 20x50 11



201304/27 91 ■
 Amber Beige
 20x50 6



201342/16 51 ■
 Bacc. Napel Beige
 2,5x50 12



201341/29 10 ■
 List. Etnic Beige
 6x50 12



201306/12 36 ■
 List. Amber Beige
 4,5x50 12

Gres Porcellanato Pavimenti consigliati / Suitable floor tiles / Carreaux pour sol coordonnés / Bodenfliesen-empfehlung



R02446/32 66 ■
 Cristallo HR PEI IV
 31x31 14



R02442/32 66 ■
 Chisa HR PEI IV
 30,5x30,5 14



R02447/32 66 ■
 Corda HR PEI IV
 30,5x30,5 14

pesi e misure / weight and sizes / poids et mesures / Gewichte und Verpackungen

dimensioni sizes dimensions abmessungen	spessore thickness épaisseur stärke	pz/collo pcs/box pc/boite stk/ktn	mq/collo sqm/box m/boite qm/ktn	kg/collo kg/box kg/boite kg/ktn	colli/europal box/europal boites/europal ktn/europal	mq/europal sqm/europal m/europal qm/europal	kg/europal kg/europal kg/europal kg/europal
Fondo 20x50	9 mm	11	1,10	16	64	70,4	1040
Pavimento HR 30,5x30,5	9 mm	14	1,30	23,10	72	93,6	1680
Pavimento HR 31x31	9 mm	14	1,35	24,00	72	97,20	1750





TT0818 Espositore serie City
 cm 52x115x160 1
 Pannelli cm 52x135 6

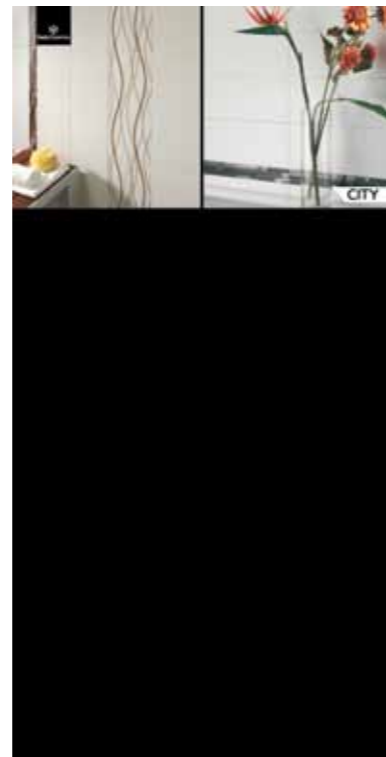

TTP064 Pannello Sinottico serie City
 cm 100x200



Faesite serie City
 cm 55x87

verve

Rivestimento in bicottura
 Double-fired wall tiles
 Revêtement bicuisson
 Zweibrandverfahren Wandfliese

25x45
 10"x18"





Fondi / Base tiles / Fonds / Grundfliesen

301436/27 07	301439/27 07	301440/27 07	301437/27 07
Verve Bianco	Verve Azzurro	Verve Tortora	Verve Rosa
25x45 16	25x45 16	25x45 16	25x45 16
201479/06 19	201482/06 19	201483/06 19	201480/06 19
Bacchetta Verve Bianco	Bacchetta Verve Azzurro	Bacchetta Verve Tortora	Bacchetta Verve Rosa
2x45 24	2x45 24	2x45 24	2x45 24
302654/33 55	302655/33 55	302656/33 55	302657/33 55
L2 Verve Bianco	L2 Verve Azzurro	L2 Verve Tortora	L2 Verve Rosa
25x45 16	25x45 16	25x45 16	25x45 16
001182/09 27	001186/09 27	001183/09 27	001185/09 27
D. Vela Bianco	D. Vela Azzurro	D. Vela Tortora	D. Vela Rosa
12,5x45 12	12,5x45 12	12,5x45 12	12,5x45 12

Fondi / Base tiles / Fonds / Grundfliesen

301442/27 07	301438/27 07	301509/31 13	301510/31 13
Verve Lilla	Verve Verde	Mosaico Verve Azzurro	Mosaico Verve Tortora
25x45 16	25x45 16	25x45 16	25x45 16
201485/06 19	201481/06 19	201571/04 47	201572/04 47
Bacchetta Verve Lilla	Bacchetta Verve Verde	Listello Mosaico Verve Azzurro	Listello Mosaico Verve Tortora
2x45 24	2x45 24	5x45 18	5x45 18
302658/33 55	302659/33 55	301512/31 13	301511/31 13
L2 Verve Lilla	L2 Verve Verde	Mosaico Verve Rosa	Mosaico Verve Lilla
25x45 16	25x45 16	25x45 16	25x45 16
001184/09 27	001187/09 27	201573/04 47	201574/04 47
D. Vela Lilla	D. Vela Verde	Listello Mosaico Verve Rosa	Listello Mosaico Verve Lilla
12,5x45 12	12,5x45 12	5x45 18	5x45 18

Gres Porcellanato Pavimenti consigliati / Suitable floor tiles / Carreaux pour sol coordonnés / Bodenfliesen-empfehlung

R02446/32 66	301618/32 66	R02548/32 66	R02440/32 66
Cristallo HR	Turchese HR	Tortora HR	Fuxia HR
31x31 14	33,3x33,3 14	30,5x30,5 14	30,5x30,5 14

301617/32 66	R02385/32 66	301508/31 13	201575/04 47
Lilla HR	Menta HR	Mosaico Verve Verde	Listello Mosaico Verve Verde
33,3x33,3 14	30,5x30,5 14	25x45 16	5x45 18

pesi e misure / weight and sizes / poids et mesures / Gewichte und Verpackungen								
dimensioni sizes dimensions abmessungen	spessore thickness épaisseur stärke	pz/collo pcs/box pc/boite stk/ktn	mq/collo sqm/box m/boite qm/ktn	kg/collo kg/box kg/boite kg/ktn	colli/europal box/europal boites/europal ktn/europal	mq/europal sqm/europal m/europal qm/europal	kg/europal kg/europal kg/europal kg/europal	
Fondo 25x45 - Fondo L2 25x45 - Mosaico 25x45	8,5 mm	16	1,80	28,0	52	93,60	1480	
Pavimento HR 30,5x30,5	9 mm	14	1,30	23,10	72	93,60	1680	

pesi e misure / weight and sizes / poids et mesures / Gewichte und Verpackungen								
dimensioni sizes dimensions abmessungen	spessore thickness épaisseur stärke	pz/collo pcs/box pc/boite stk/ktn	mq/collo sqm/box m/boite qm/ktn	kg/collo kg/box kg/boite kg/ktn	colli/europal box/europal boites/europal ktn/europal	mq/europal sqm/europal m/europal qm/europal	kg/europal kg/europal kg/europal kg/europal	
Pavimento HR 31x31	9 mm	14	1,35	24,00	72	97,20	1750	
Pavimento HR 33,3x33,3	9 mm	14	1,55	28,50	48	74,40	1372	

Decori / Decorations / Décorations / Dekors

001155/15 39 ■ D. Living Azzurro 25x45 6	001159/33 55 ■ D. Ritmo Azzurro 25x45 6	001137/34 61 ■ D. Royal A 25x45 6	001181/09 29 ■ Verve Bianco Taglio 4x10 25x45 6
001158/15 39 ■ D. Living Tortora 25x45 6	001161/37 54 ■ D. Circle Azzurro 25x45 6	001138/34 61 ■ D. Royal B 25x45 6	201511/08 25 ■ Tozz. Baccarat Tortora 4x10 12
001157/15 39 ■ D. Living Rosa 25x45 6	001141/33 55 ■ D. Ritmo Verde 25x45 6	001139/34 61 ■ D. Royal C 25x45 6	201512/08 25 ■ Tozz. Baccarat Lilla 4x10 12
001143/15 39 ■ D. Living Lilla 25x45 6	001142/37 54 ■ D. Circle Verde 25x45 6	001140/34 61 ■ D. Royal D 25x45 6	201513/08 25 ■ Tozz. Baccarat Azzurro 4x10 12
001156/15 39 ■ D. Living Verde 25x45 6	201489/13 37 ■ Listello Royal 6x45 12	201507/31 13 ■ Bacc. Baccarat Tortora 4x45 10	201514/08 25 ■ Tozz. Baccarat Verde 4x10 12
	201508/31 13 ■ Bacc. Baccarat Lilla 4x45 10	201509/31 13 ■ Bacc. Baccarat Azzurro 4x45 10	201510/31 13 ■ Bacc. Baccarat Verde 4x45 10

Decori / Decorations / Décorations / Dekors

001135/29 10 ■ D. Primula Rosa 25x45 6	001136/29 10 ■ D. Primula Lilla 25x45 6	001152/27 07 ■ D. Ginger Bianco 25x45 6	001153/27 07 ■ D. Ginger Tortora 25x45 6
201638/22 42 ■ Delizia A 25x45 6	201648/22 42 ■ Delizia B 25x45 6	001147/28 08 ■ D. Gladys 25x45 6	201499/15 39 ■ Listello Ginger 6x45 12

Gres Porcellanato Pavimenti consigliati / Suitable floor tiles / Carreaux pour sol coordonnés / Bodenfliesen-empfehlung

TP7500/40 15 ■ 15x60,6 Crema Rett. 14	TP7550/40 15 ■ 15x60,6 Mandorla Rett. 14	TP7600/40 15 ■ 15x60,6 Nocciola Rett. 14
TP7700/40 15 ■ 15x60,6 Cioccolato Rett. 14	TP7800/40 15 ■ 15x60,6 Amarena Rett. 14	TP7900/40 15 ■ 15x60,6 Caffè Rett. 14
TP7650/40 15 ■ 15x60,6 Liquirizia Rett. 14	TP7850/40 15 ■ 15x60,6 Straciatella Rett. 14	TP7750/40 15 ■ 15x60,6 Fondente Rett. 14

pesi e misure / weight and sizes / poids et mesures / Gewichte und Verpackungen							
dimensioni sizes dimensions abmessungen	spessore thickness épaisseur stärke	pz/collo pcs/box pc/boite stk/ktn	mq/collo sqm/box m/boite qm/ktn	kg/collo kg/box kg/boite kg/ktn	colli/europal box/europal boites/europal ktn/europal	mq/europal sqm/europal m/europal qm/europal	kg/europal kg/europal kg/europal kg/europal
Legni in gres 15x60,6 Rett. Lapp.	9 mm	14	1,273	22,50	50	63,65	1125

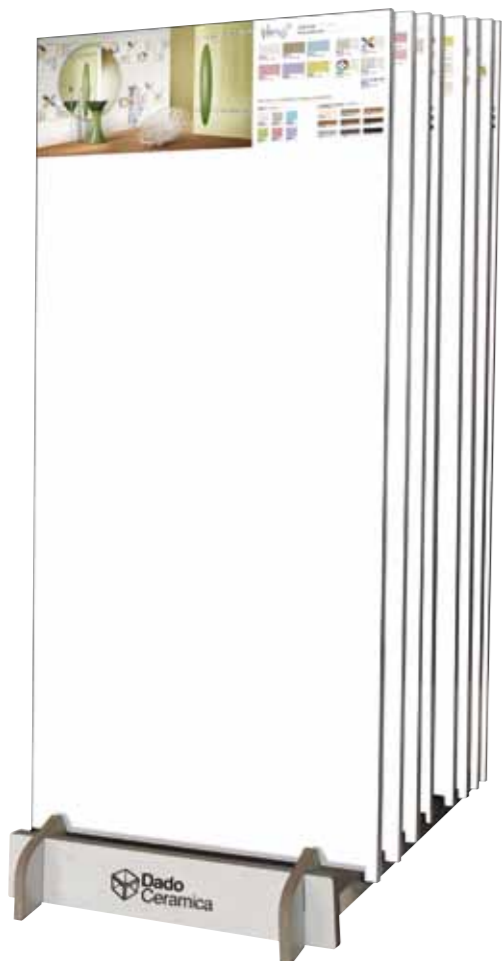

TT0901 Espositore serie Verve
 cm 64x115x160 1
 Pannelli cm 64x135 8



TTP057 Pannello Sinottico serie Verve
 cm 100x200

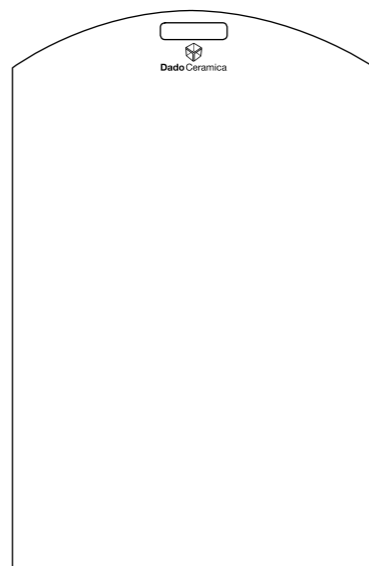

Faesite serie Verve
 cm 55x87

notte brava

Rivestimento in bicottura
 Double-fired wall tiles
 Revêtement bicuisson
 Zweibrandverfahren Wandfliese

20x33,3
 8"x13"



Rivestimento in bicottura / Double-fired wall tiles
 Revêtement b cuisson / Zweibrandverfahren Wandfliese

Lambada



302772/32 66 ■
 Lambada Mix Grey
 20x33,3 18



302784/32 66 ■
 Lambada Mix Blue
 20x33,3 18



302786/32 66 ■
 Lambada Mix Lilla
 20x33,3 18



302773/32 66 ■
 Lambada Mix Sand
 20x33,3 18



302785/32 66 ■
 Lambada Mix Moka
 20x33,3 18

201653/55 97 ■
 Profilo in Alluminio anodizzato lucido
 1,2x1,2x200 10

201652/40 15 ■
 Profilo in Alluminio anodizzato satinato
 1,2x1,2x200 10

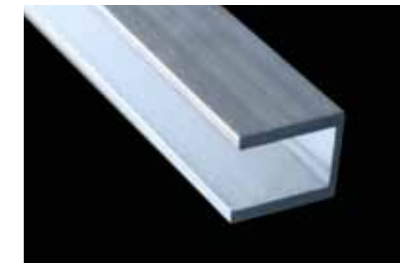

PROFILO IN ALLUMINIO idoneo ad ospitare il lato della piastrella sagomata con la funzione di copri-
 filo per l'unione di 2 formati diversi tra loro
 Aluminium section suitable for containing the edge of the shaped tile, acting as a cover for joining two different tile sizes
 / PROFILÉ EN ALUMINIUM pouvant recevoir le côté profilé du carreau, avec fonction de baguette pour la jonction de 2
 formats différents / ALUMINIUMPROFIL, in das die Seitenkante der geformten Fliese eingefügt werden kann und das als
 Kantenschutz für die Verbindung von 2 untereinander verschiedenen Formaten dient.



note / notes / notes / anmerkungen

Si consiglia di seguire le istruzioni per l'installazione presenti a pag. 201/206

We recommend to follow the laying instructions at page 201/206 / Il est conseillé de suivre les conseils de pose à la page 201/206 / Um eine korrekte Arbeit zu führen wird es empfohlen auf die Anweisungen der Seite 201/206 zu achten.

pesi e misure / weight and sizes / poids et mesures / Gewichte und Verpackungen

dimensioni sizes dimensions abmessungen	spessore thickness épaisseur stärke	pz/collo pcs/box pc/boite stk/ktn	mq/collo sqm/box m/boite qm/ktn	kg/collo kg/box kg/boite kg/ktn	colli/europal box/europal boites/europal ktn/europal	mq/europal sqm/europal m/europal qm/europal	kg/europal kg/europal kg/europal kg/europal
Fondo 20x33,3	8 mm	18	1,20	14,50	51	61,20	760

Rivestimento in bicottura / Double-fired wall tiles
 Revêtement b cuisson / Zweibrandverfahren Wandfliese

Rumba



302689/32 66 ■
 Rumba Bianco
 20x33,3 18 ▽



302694/32 66 ■
 Rumba Grigio
 20x33,3 18 ▽



302690/35 96 ■
 Rumba Nero
 20x33,3 18 ▽

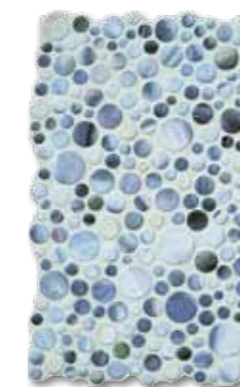

302705/32 66 ■
 Rumba Blue
 20x33,3 18 ▽

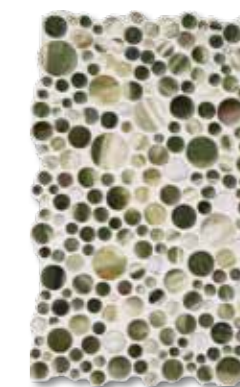

302706/32 66 ■
 Rumba Verde
 20x33,3 18 ▽



302704/37 54 ■
 Rumba Rame
 20x33,3 18 ▽



302707/32 66 ■
 Rumba Beige
 20x33,3 18 ▽



302692/32 66 ■
 Rumba Rosa
 20x33,3 18 ▽



302691/32 66 ■
 Rumba Lilla
 20x33,3 18 ▽

201653/55 97 ■

Profilo in Alluminio anodizzato lucido
 1,2x1,2x200 10 ▽

201652/40 15 ■

Profilo in Alluminio anodizzato satinato
 1,2x1,2x200 10 ▽

PROFILO IN ALLUMINIO idoneo ad ospitare il lato della piastrella sagomata con la funzione di coprifilo per l'unione di 2 formati diversi tra loro
 Aluminium section suitable for containing the edge of the shaped tile, acting as a cover for joining two different tile sizes / PROFILÉ EN ALUMINIUM pouvant recevoir le côté profilé du carreau, avec fonction de baguette pour la jonction de 2 formats différents / ALUMINIUMPROFIL, in das die Seitenkante der geformten Fliese eingefügt werden kann und das als Kantenschutz für die Verbindung von 2 untereinander verschiedenen Formaten dient.

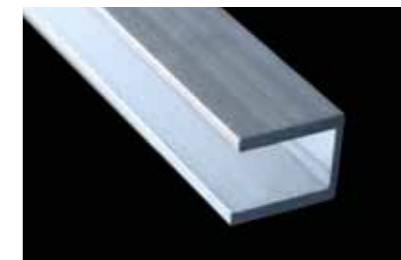

note / notes / notes / anmerkungen

Si consiglia di seguire le istruzioni per l'installazione presenti a pag. 201/206

We recommend to follow the laying instructions at page 201/206 / Il est conseillé de suivre les conseils de pose à la page 201/206 / Um eine korrekte Arbeit zu führen wird es empfohlen auf die Anweisungen der Seite 201/206 zu achten.

pesi e misure / weight and sizes / poids et mesures / Gewichte und Verpackungen

dimensioni sizes dimensions abmessungen	spessore thickness épaisseur stärke	pz/collo pcs/box pc/boite stk/ktn	mq/collo sqm/box m/boite qm/ktn	kg/collo kg/box kg/boite kg/ktn	colli/europal box/europal boites/europal ktn/europal	mq/europal sqm/europal m/europal qm/europal	kg/europal kg/europal kg/europal kg/europal
Fondo 20x33,3	8 mm	18	1,20	14,50	51	61,20	760





Rivestimento in bicottura / Double-fired wall tiles
 Revêtement biccuisson / Zweibrandverfahren Wandfliese

Jive



302591/32 66 ■
 Jive Bianco
 20x33,3 18



302595/32 66 ■
 Jive Blue
 20x33,3 18



302757/32 66 ■
 Jive Arancio
 20x33,3 18

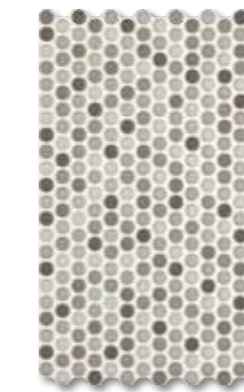

302775/32 66 ■
 Jive Mix Grigio
 20x33,3 18



302776/32 66 ■
 Jive Mix Beige
 20x33,3 18



302758/32 66 ■
 Jive Senape
 20x33,3 18



302593/32 66 ■
 Jive Lilla
 20x33,3 18



302594/32 66 ■
 Jive Tortora
 20x33,3 18



302761/32 66 ■
 Jive Mix Lilla
 20x33,3 18



302760/32 66 ■
 Jive Mix Tortora
 20x33,3 18

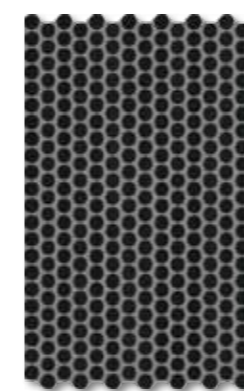

302592/35 96 ■
 Jive Nero
 20x33,3 18

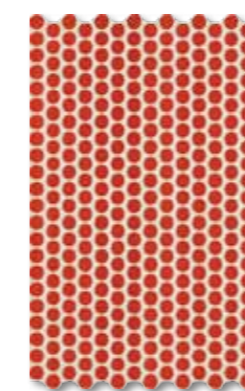

302756/37 54 ■
 Jive Rosso
 20x33,3 18

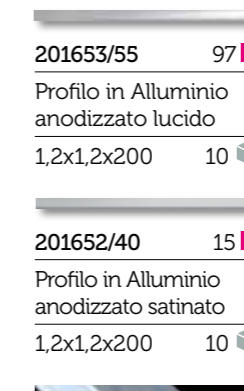

302759/32 66 ■
 Jive Mix Nero
 20x33,3 18

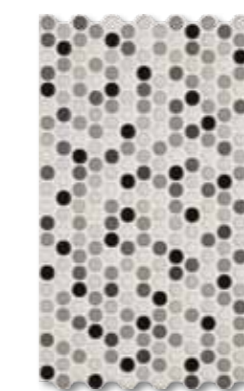

302762/32 66 ■
 Jive Mix Arancio
 20x33,3 18

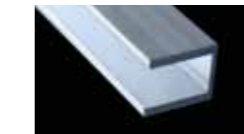

201653/55 97 ■
 Profilo in Alluminio
 anodizzato lucido
 1,2x1,2x200 10

201652/40 15 ■
 Profilo in Alluminio
 anodizzato satinato
 1,2x1,2x200 10

note / notes / notes / anmerkungen

Si consiglia di seguire le istruzioni per l'installazione presenti a pag. 201/206

We recommend to follow the laying instructions at page 201/206 / Il est conseillé de suivre les conseils de pose à la page 201/206 / Um eine korrekte Arbeit zu führen wird es empfohlen auf die Anweisungen der Seite 201/206 zu achten.

pesi e misure / weight and sizes / poids et mesures / Gewichte und Verpackungen

dimensioni sizes dimensions abmessungen	spessore thickness épaisseur stärke	pz/collo pcs/box pc/boite stk/ktn	mq/collo sqm/box m/boite qm/ktn	kg/collo kg/box kg/boite kg/ktn	colli/europal box/europal boites/europal ktn/europal	mq/europal sqm/europal m/europal qm/europal	kg/europal kg/europal kg/europal kg/europal
Fondo 20x33,3	8 mm	18	1,20	14,50	51	61,20	760

Rivestimento in bicottura / Double-fired wall tiles
 Revêtement biccuisson / Zweibrandverfahren Wandfliese

Tango



302709/32 66 ■
 Tango Grigio
 20x33,3 18 ▽



302710/32 66 ■
 Tango Lilla
 20x33,3 18 ▽



302715/32 66 ■
 Tango Azzurro
 20x33,3 18 ▽



302725/32 66 ■
 Tango Verde
 20x33,3 18 ▽



302722/37 54 ■
 Tango Beige
 20x33,3 18 ▽



302724/32 66 ■
 Tango Marrone
 20x33,3 18 ▽



302723/32 66 ■
 Tango Arancio
 20x33,3 18 ▽



302787/32 66 ■
 Tango Stone Beige
 20x33,3 18 ▽



302788/32 66 ■
 Tango Stone Grey
 20x33,3 18 ▽

201653/55 97 ■
 Profilo in Alluminio anodizzato lucido
 1,2x1,2x200 10 ▽

201652/40 15 ■
 Profilo in Alluminio anodizzato satinato
 1,2x1,2x200 10 ▽

PROFILO IN ALLUMINIO idoneo ad ospitare il lato della piastrella sagomata con la funzione di copri-
 filo per l'unione di 2 formati diversi tra loro
 Aluminium section suitable for containing the edge of the shaped tile, acting as a cover for joining two different tile sizes
 / PROFILÉ EN ALUMINIUM pouvant recevoir le côté profilé du carreau, avec fonction de baguette pour la jonction de 2
 formats différents / ALUMINIUMPROFIL, in das die Seitenkante der geformten Fliese eingefügt werden kann und das als
 Kantenschutz für die Verbindung von 2 untereinander verschiedenen Formaten dient.

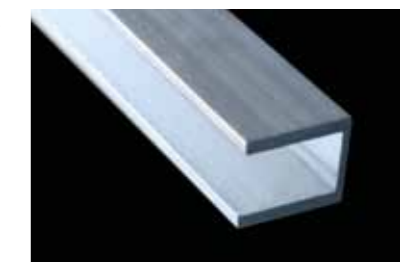

note / notes / notes / anmerkungen

Si consiglia di seguire le istruzioni per l'installazione presenti a pag. 201/206

We recommend to follow the laying instructions at page 201/206 / Il est conseillé de suivre les conseils de pose à la page 201/206 / Um eine korrekte Arbeit zu führen wird es empfohlen auf die Anweisungen der Seite 201/206 zu achten.

pesi e misure / weight and sizes / poids et mesures / Gewichte und Verpackungen

dimensioni sizes dimensions abmessungen	spessore thickness épaisseur stärke	pz/collo pcs/box pc/boite stk/ktn	mq/collo sqm/box m/boite qm/ktn	kg/collo kg/box kg/boite kg/ktn	colli/eurol box/eurol boites/eurol ktn/eurol	mq/eurol sqm/eurol m/eurol qm/eurol	kg/eurol kg/eurol kg/eurol kg/eurol
Fondo 20x33,3	8 mm	18	1,20	14,50	51	61,20	760



Rivestimento in bicottura / Double-fired wall tiles
 Revêtement biccuisson / Zweibrandverfahren Wandfliese

Salsa



302684/32 66 ■
 Salsa Bianco
 20x33,3 18 ▽



302703/37 54 ■
 Salsa Copper
 20x33,3 18 ▽



302685/35 96 ■
 Salsa Nero
 20x33,3 18 ▽



302708/32 66 ■
 Salsa Verde
 20x33,3 18 ▽



302686/32 66 ■
 Salsa Beige
 20x33,3 18 ▽



302687/32 66 ■
 Salsa Giallo
 20x33,3 18 ▽



302688/32 66 ■
 Salsa Arancio
 20x33,3 18 ▽

201653/55 97 ■
 Profilo in Alluminio anodizzato lucido
 1,2x1,2x200 10 ▽

201652/40 15 ■
 Profilo in Alluminio anodizzato satinato
 1,2x1,2x200 10 ▽

PROFILO IN ALLUMINIO idoneo ad ospitare il lato della piastrella sagomata con la funzione di copri-
 filo per l'unione di 2 formati diversi tra loro
 Aluminium section suitable for containing the edge of the shaped tile, acting as a cover for joining two different tile sizes
 / PROFILÉ EN ALUMINIUM pouvant recevoir le côté profilé du carreau, avec fonction de baguette pour la jonction de 2
 formats différents / ALUMINIUMPROFIL, in das die Seitenkante der geformten Fliese eingefügt werden kann und das als
 Kantenschutz für die Verbindung von 2 untereinander verschiedenen Formaten dient.

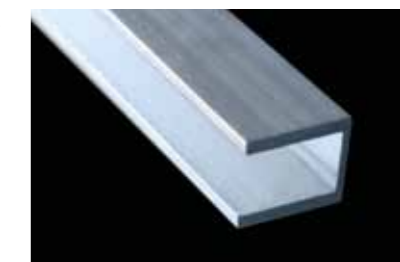

note / notes / notes / anmerkungen

Si consiglia di seguire le istruzioni per l'installazione presenti a pag. 201/206

We recommend to follow the laying instructions at page 201/206 / Il est conseillé de suivre les conseils de pose à la page 201/206 / Um eine korrekte Arbeit zu führen wird es empfohlen auf die Anweisungen der Seite 201/206 zu achten.

pesi e misure / weight and sizes / poids et mesures / Gewichte und Verpackungen







dimensioni sizes dimensions abmessungen	spessore thickness épaisseur stärke	pz/collo pcs/box pc/boite stk/ktn	mq/collo sqm/box m/boite qm/ktn	kg/collo kg/box kg/boite kg/ktn	colli/eurol box/eurol boites/eurol ktn/eurol	mq/eurol sqm/eurol m/eurol qm/eurol	kg/eurol kg/eurol kg/eurol kg/eurol
Fondo 20x33,3	8 mm	18	1,20	14,50	51	61,20	760





Rivestimento in bicottura / Double-fired wall tiles
 Revêtement b cuisson / Zweibrandverfahren Wandfliese

Swing

			
302677/32 66 ■	302673/32 66 ■	302675/37 54 ■	
Swing Beige	Swing Moka	Swing Nero	
20x33,3 18	20x33,3 18	20x33,3 18	
			
302671/32 66 ■	302672/32 66 ■	302676/32 66 ■	302674/32 66 ■
Swing Oliva	Swing Arancio	Swing Bluette	Swing Rosa
20x33,3 18	20x33,3 18	20x33,3 18	20x33,3 18

201653/55 97 ■	201652/40 15 ■
Profilo in Alluminio anodizzato lucido	Profilo in Alluminio anodizzato satinato
1,2x1,2x200 10	1,2x1,2x200 10

PROFILO IN ALLUMINIO idoneo ad ospitare il lato della piastrella sagomata con la funzione di copri-filo per l'unione di 2 formati diversi tra loro
 Aluminium section suitable for containing the edge of the shaped tile, acting as a cover for joining two different tile sizes
 / PROFILÉ EN ALUMINIUM pouvant recevoir le côté profilé du carreau, avec fonction de baguette pour la jonction de 2 formats différents / ALUMINIUMPROFIL, in das die Seitenkante der geformten Fliese eingefügt werden kann und das als Kantenschutz für die Verbindung von 2 untereinander verschiedenen Formaten dient.

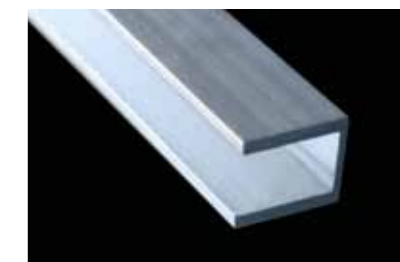

note / notes / notes / anmerkungen

Si consiglia di seguire le istruzioni per l'installazione presenti a pag. 201/206
 We recommend to follow the laying instructions at page 201/206 / Il est conseillé de suivre les conseils de pose à la page 201/206 / Um eine korrekte Arbeit zu führen wird es empfohlen auf die Anweisungen der Seite 201/206 zu achten.

pesi e misure / weight and sizes / poids et mesures / Gewichte und Verpackungen

dimensioni sizes dimensions abmessungen	spessore thickness épaisseur stärke	pz/collo pcs/box pc/boite stk/ktn	mq/collo sqm/box m/boite qm/ktn	kg/collo kg/box kg/boite kg/ktn	colli/europal box/europal boites/europal ktn/europal	mq/europal sqm/europal m/europal qm/europal	kg/europal kg/europal kg/europal kg/europal
Fondo 20x33,3	8 mm	18	1,20	14,50	51	61,20	760



Rivestimento in bicottura / Double-fired wall tiles
 Revêtement bicusson / Zweibrandverfahren Wandfliese

Mambo

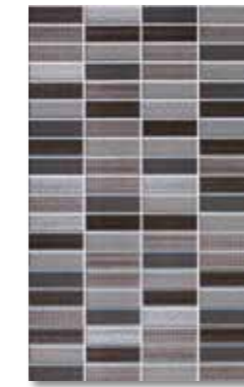

302696/35 96 ■
 Mambo Nero
 20x33,3 18



302714/32 66 ■
 Mambo Ruggine
 20x33,3 18

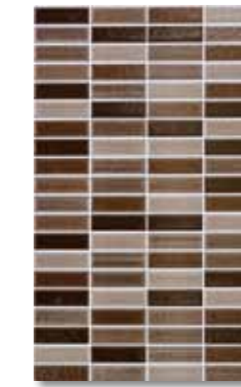

302713/32 66 ■
 Mambo Moka
 20x33,3 18



302695/37 54 ■
 Mambo Rame
 20x33,3 18



302712/32 66 ■
 Mambo Verde
 20x33,3 18

Merengue



302670/32 66 ■
 Merengue Blanchis
 20x33,3 18



302669/32 66 ■
 Merengue Beige
 20x33,3 18

201653/55 97 ■
 Profilo in Alluminio anodizzato lucido
 1,2x1,2x200 10

201652/40 15 ■
 Profilo in Alluminio anodizzato satinato
 1,2x1,2x200 10

PROFILO IN ALLUMINIO idoneo ad ospitare il lato della piastrella sagomata con la funzione di copri-filo per l'unione di 2 formati diversi tra loro
 Aluminium section suitable for containing the edge of the shaped tile, acting as a cover for joining two different tile sizes
 / PROFILÉ EN ALUMINIUM pouvant recevoir le côté profilé du carreau, avec fonction de baguette pour la jonction de 2 formats différents / ALUMINIUMPROFIL, in das die Seitenkante der geformten Fliese eingefügt werden kann und das als Kantenschutz für die Verbindung von 2 untereinander verschiedenen Formaten dient.

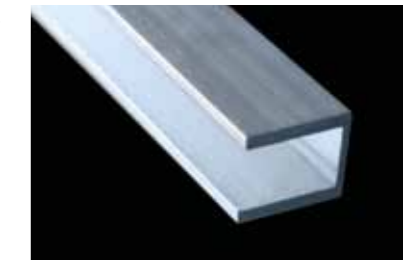

note / notes / notes / anmerkungen

Si consiglia di seguire le istruzioni per l'installazione presenti a pag. 201/206

We recommend to follow the laying instructions at page 201/206 / Il est conseillé de suivre les conseils de pose à la page 201/206 / Um eine korrekte Arbeit zu führen wird es empfohlen auf die Anweisungen der Seite 201/206 zu achten.

pesi e misure / weight and sizes / poids et mesures / Gewichte und Verpackungen

dimensioni sizes dimensions abmessungen	spessore thickness épaisseur stärke	pz/collo pcs/box pc/boite stk/ktn	mq/collo sqm/box m/boite qm/ktn	kg/collo kg/box kg/boite kg/ktn	colli/europal box/europal boites/europal ktn/europal	mq/europal sqm/europal m/europal qm/europal	kg/europal kg/europal kg/europal kg/europal
Fondo 20x33,3	8 mm	18	1,20	14,50	51	61,20	760

Rivestimento in bicottura / Double-fired wall tiles
 Revêtement biccuisson / Zweibrandverfahren Wandfliese

Reggaeton



302700/32 66 ■
 Reggaeton Blanchis
 20x33,3 18 ▽



302701/32 66 ■
 Reggaeton Beige
 20x33,3 18 ▽



302702/32 66 ■
 Reggaeton Marmo
 20x33,3 18 ▽



302697/32 66 ■
 Reggaeton Giallo
 20x33,3 18 ▽



302699/35 96 ■
 Reggaeton Nero
 20x33,3 18 ▽



302698/32 66 ■
 Reggaeton Verde
 20x33,3 18 ▽

201653/55 97 ■
 Profilo in Alluminio anodizzato lucido
 1,2x1,2x200 10 ▽

201652/40 15 ■
 Profilo in Alluminio anodizzato satinato
 1,2x1,2x200 10 ▽

PROFILO IN ALLUMINIO idoneo ad ospitare il lato della piastrella sagomata con la funzione di copri-filo per l'unione di 2 formati diversi tra loro
 Aluminium section suitable for containing the edge of the shaped tile, acting as a cover for joining two different tile sizes
 / PROFILÉ EN ALUMINIUM pouvant recevoir le côté profilé du carreau, avec fonction de baguette pour la jonction de 2 formats différents / ALUMINIUMPROFIL, in das die Seitenkante der geformten Fliese eingefügt werden kann und das als Kantenschutz für die Verbindung von 2 untereinander verschiedenen Formaten dient.

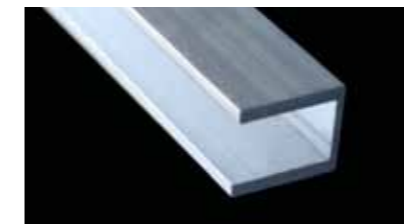

note / notes / notes / anmerkungen

Si consiglia di seguire le istruzioni per l'installazione presenti a pag. 201/206

We recommend to follow the laying instructions at page 201/206 / Il est conseillé de suivre les conseils de pose à la page 201/206 / Um eine korrekte Arbeit zu führen wird es empfohlen auf die Anweisungen der Seite 201/206 zu achten.

pesi e misure / weight and sizes / poids et mesures / Gewichte und Verpackungen

dimensioni sizes dimensions abmessungen	spessore thickness épaisseur stärke	pz/collo pcs/box pc/boite stk/ktn	mq/collo sqm/box m/boite qm/ktn	kg/collo kg/box kg/boite kg/ktn	colli/europal box/europal boites/europal ktn/europal	mq/europal sqm/europal m/europal qm/europal	kg/europal kg/europal kg/europal kg/europal
Fondo 20x33,3	8 mm	18	1,20	14,50	51	61,20	760



Rivestimento in bicottura / Double-fired wall tiles
 Revêtement biccuisson / Zweibrandverfahren Wandfliese

Cha Cha Cha



302678/32 66 ■
 Cha Cha Cha Bianco
 20x33,3 18

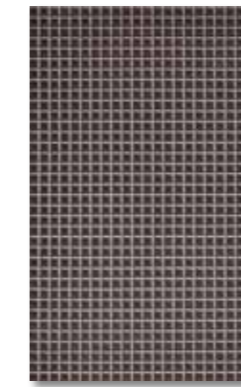

302682/32 66 ■
 Cha Cha Cha Antracite
 20x33,3 18

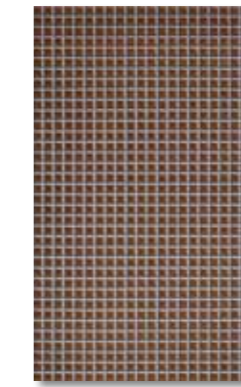

302683/37 54 ■
 Cha Cha Cha Rame
 20x33,3 18



302679/32 66 ■
 Cha Cha Cha Lilla
 20x33,3 18

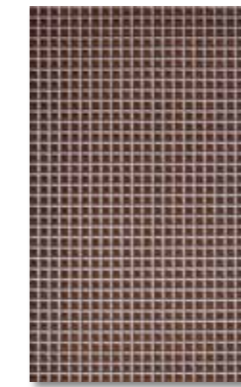

302681/32 66 ■
 Cha Cha Cha Caffè
 20x33,3 18



302680/32 66 ■
 Cha Cha Cha Beige
 20x33,3 18

201653/55 97 ■
 Profilo in Alluminio anodizzato lucido
 1,2x1,2x200 10

201652/40 15 ■
 Profilo in Alluminio anodizzato satinato
 1,2x1,2x200 10

PROFILO IN ALLUMINIO idoneo ad ospitare il lato della piastrella sagomata con la funzione di copri-
 filo per l'unione di 2 formati diversi tra loro
 Aluminium section suitable for containing the edge of the shaped tile, acting as a cover for joining two different tile sizes
 / PROFILÉ EN ALUMINIUM pouvant recevoir le côté profilé du carreau, avec fonction de baguette pour la jonction de 2
 formats différents / ALUMINIUMPROFIL, in das die Seitenkante der geformten Fliese eingefügt werden kann und das als
 Kantenschutz für die Verbindung von 2 untereinander verschiedenen Formaten dient.

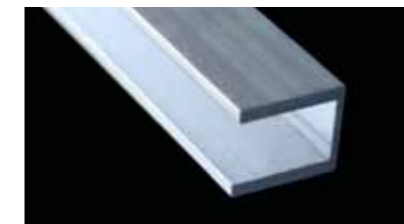

note / notes / notes / anmerkungen

Si consiglia di seguire le istruzioni per l'installazione presenti a pag. 201/206

We recommend to follow the laying instructions at page 201/206 / Il est conseillé de suivre les conseils de pose à la page 201/206 / Um eine korrekte Arbeit zu führen wird es empfohlen auf die Anweisungen der Seite 201/206 zu achten.

pesi e misure / weight and sizes / poids et mesures / Gewichte und Verpackungen

dimensioni sizes dimensions abmessungen	spessore thickness épaisseur stärke	pz/collo pcs/box pc/boite stk/ktn	mq/collo sqm/box m/boite qm/ktn	kg/collo kg/box kg/boite kg/ktn	colli/europol box/europol boites/europol ktn/europol	mq/europol sqm/europol m/europol qm/europol	kg/europol kg/europol kg/europol kg/europol
Fondo 20x33,3	8 mm	18	1,20	14,50	51	61,20	760



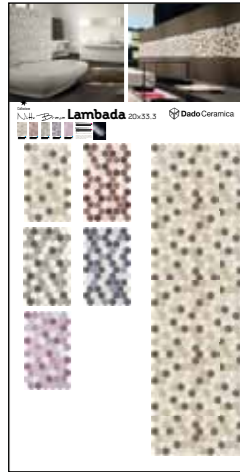

TTP084 Pannello Sinottico serie Notte Brava Lambada

cm 100x200



TTP085 Pannello Sinottico serie Notte Brava Rumba

cm 100x200

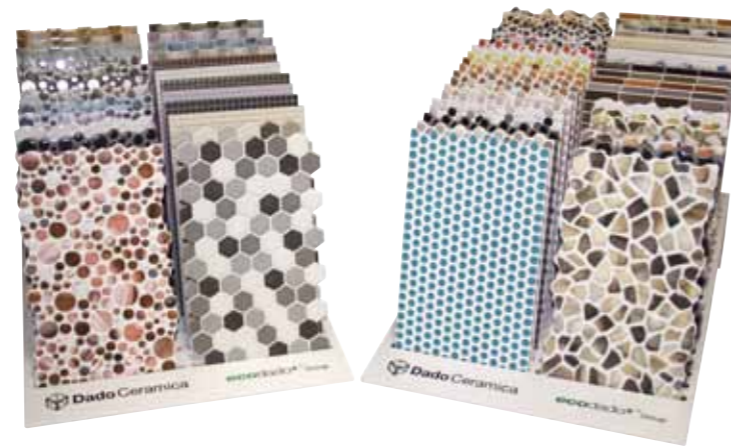

TTP098 Espositore Notte Brava

cm 63x45x45 1

Mosaici cm 20x33,3 cad. 40

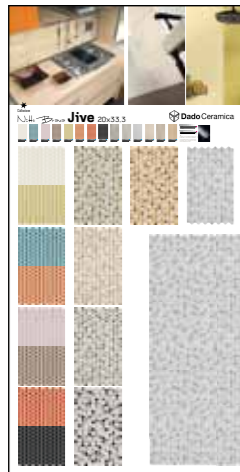

TTP086 Pannello Sinottico serie Notte Brava Jive

cm 100x200



TTP087 Pannello Sinottico serie Notte Brava Tango

cm 100x200

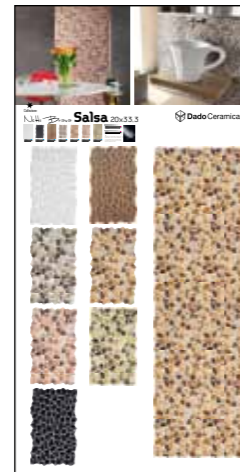

TTP088 Pannello Sinottico serie Notte Brava Salsa

cm 100x200



TTP089 Pannello Sinottico serie Notte Brava Swing

cm 100x200

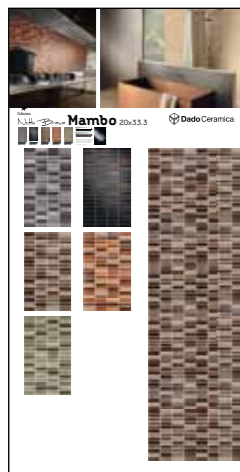

TTP090 Pannello Sinottico serie Notte Brava Mambo

cm 100x200



TTP091 Pannello Sinottico serie Notte Brava Merengue

cm 100x200

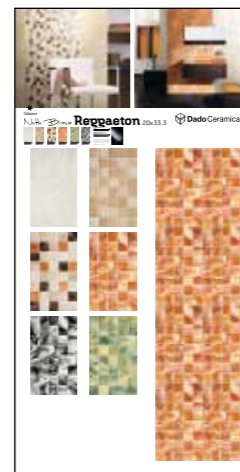

TTP092 Pannello Sinottico serie Notte Brava Reggaeton

cm 100x200

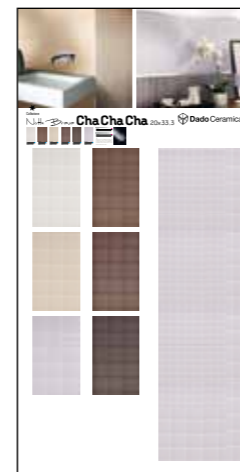

TTP093 Pannello Sinottico serie Notte Brava Cha Cha Cha

cm 100x200

UTENSILI TOOLS - OUTILS - WERKZEUG



E' di grande importanza la scelta di strumenti ed attrezzi adeguati (martello in gomma, spugna e spatola per facilitare una corretta stuccatura). L'adesivo utilizzato deve essere di tipo C1, secondo la norma EN12004 standard o superiore. Si consiglia di consultare un rivenditore di adesivi. La malta deve essere di tipo CG2 secondo EN13888 standard. In ambienti umidi, si consiglia l'uso di stucco con componenti impermeabili e resistenti a muffe.

The correct choice of tools and equipment is extremely important (rubber mallet, sponge and spatula for optimum application of grout). You should use a C1 type adhesive that complies with EN12004 standards or higher. Ask an adhesives retailer for further details. The grout must be a CG2 type that complies with EN13888 standards. When tiling rooms subject to damp conditions, we recommend using grout made with waterproof and mould resistant components.

Le choix des outils et des accessoires (marteau en caoutchouc, éponge et spatule pour un remplissage correct des joints) est d'une importance fondamentale. La colle utilisée doit être de type C1, conformément à la norme EN12004 ou toute norme supérieure. Il est conseillé de consulter un revendeur de colles. Le mortier doit être de type CG2 conformément à la norme EN13888. Dans un environnement humide, il est conseillé d'utiliser un ciment-joint dont les composants sont imperméables et résistants aux moisissures.

Die Auswahl von geeigneten Werkzeugen und Ausrüstungen (Gummihammer, Schwamm und Spachtel für ein korrektes Verfugen) ist von großer Bedeutung. Der verwendete Kleber muss gemäß Norm EN 12004 Standard dem Typ C1 oder einem höheren entsprechen. Es wird empfohlen, einen Kleberhändler zu Rate zu ziehen. Der Mörtel muss entsprechend dem Standard EN 13888 vom Typ CG2 sein. In feuchten Umgebungen wird der Einsatz von Fugenmasse mit wasserundurchlässigen und schimmelbeständigen Komponenten empfohlen.

LA POSA TILING - LA POSE - DIE VERLEGUNG

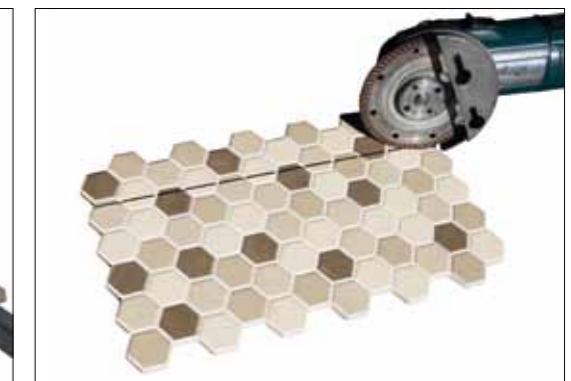

La parte da posare che è a contatto con il pavimento può essere installata con il lato sagomato oppure tagliata in linea retta. Per tagliare i pezzi si suggerisce l'utilizzo di una taglierina elettrica, poiché il sistema di taglio manuale può generare un bordo imperfetto.

The part of the tile touching the floor can be fitted with the shaped side or cut with a straight edge. We recommend using an electric tile cutter to cut the pieces since cutting by hand often results in an uneven edge.

La partie à poser en contact avec le sol peut être installée avec le bord profilé ou coupé en ligne droite. Pour couper les carreaux, il est conseillé d'utiliser une carrelante électrique, le système de coupe manuelle pouvant générer un bord imparfait.

Der Teil, der den Fußboden berührt, kann mit der geformten Seite verlegt werden oder gerade geschnitten werden. Für das Schneiden der einzelnen Teile wird der Einsatz eines elektrischen Fliesenschneiders empfohlen, da der Rand bei einem Schnitt von Hand unvollkommen sein könnte.

LA POSA TILING - LA POSE - DIE VERLEGUNG



In caso di posa (vedi foto 1), dopo aver posizionato le piastrelle dal basso verso l'alto, si installa il profilo in alluminio perfettamente a contatto con il materiale già posato, avente la "U" rivolta verso il lato sagomato della piastrella mosaicata.

Lors de la pose (voir photo 1), après avoir positionné les carreaux de bas en haut, le profilé en aluminium est installé en contact étroit avec le matériau déjà posé, le « U » étant tourné vers le bord profilé du carreau mosaïque.

When fitting the tiles (see photo 1), first put them into position working from the bottom upwards and then fit the aluminium edge, making sure it is perfectly in contact with the tiles already fitted so the "U" is facing the shaped edge of the mosaic-effect tile.

Beim Verlegen (siehe Foto 1) installiert man nach dem Anbringen der Fliesen von unten nach oben das Aluminiumprofil, das perfekt an das bereits verlegte Material angrenzen muss, wobei das U in Richtung der geformten Seite der Mosaikfliese zeigen muss.

LA POSA TILING - LA POSE - DIE VERLEGUNG

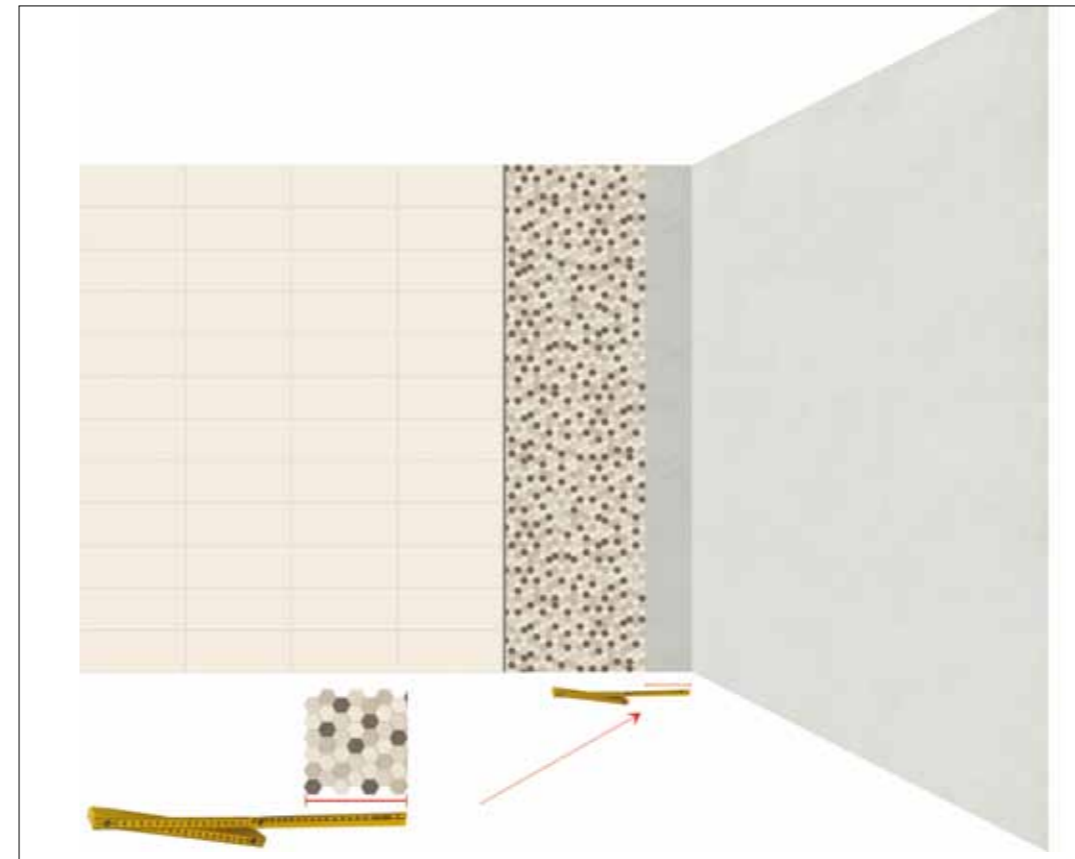

POSA ANGOLO INTERNO
Quando con la posa si arriva in prossimità di un angolo interno della parete è necessario misurare accuratamente la distanza tra l'ultima piastrella e l'angolo, al fine di effettuare un taglio corretto della piastrella da inserire. Andrà infatti reso dritto il lato che sarà a contatto con l'angolo per poi proseguire la posa sull'altra parete.

Tiling Internal Corners
When you reach an internal corner of the wall, measure the distance between the last tile and the corner accurately so that you are sure to cut the next tile correctly. The side that will be touching the corner has to be cut with a straight edge; you can then continue tiling on the adjacent wall.

Pose angle interne
Lors de la pose, lorsque l'on arrive à proximité d'un angle interne sur un mur, il convient de mesurer minutieusement la distance entre le dernier carreau et l'angle, pour que la coupe du carreau à insérer soit correcte. Le bord en contact avec l'angle devra être coupé de manière rectiligne, la pose se poursuivant ensuite sur l'autre mur.

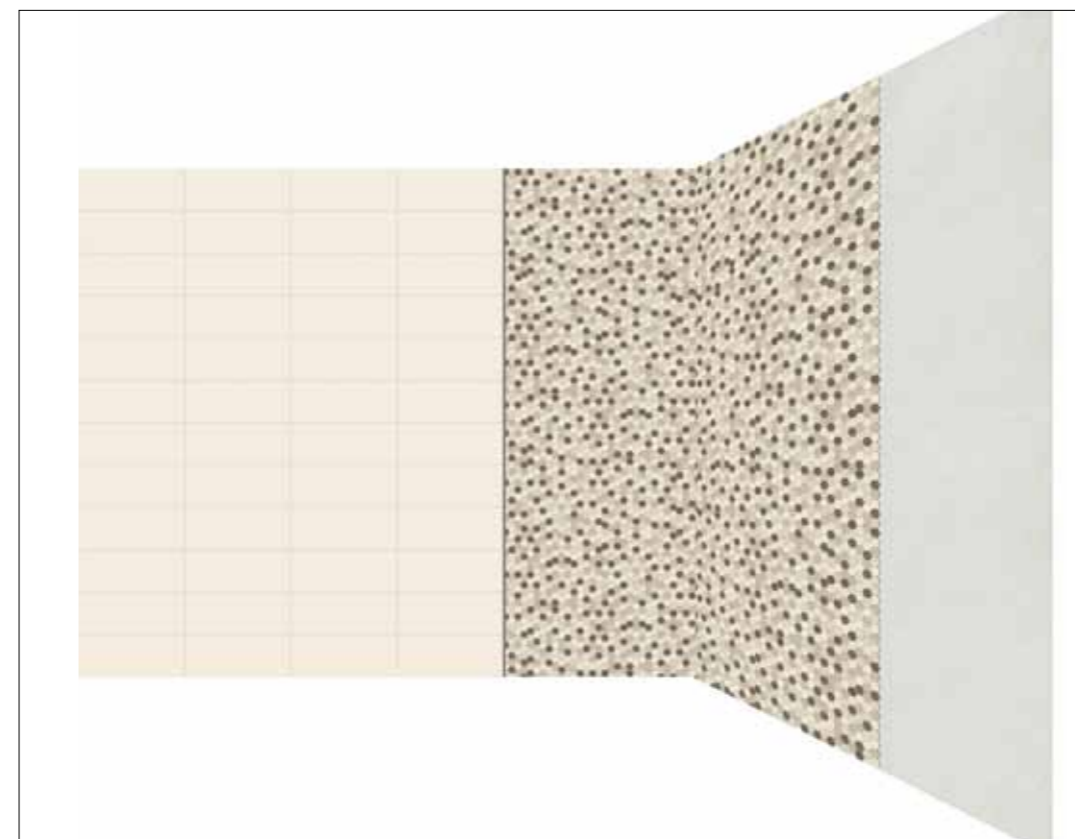

Verlegen einer Innenecke
Falls man beim Verlegen in die Nähe einer internen Wandecke kommt, muss man den Abstand zwischen der letzten Fliese und der Ecke genau abmessen, um die einzufügende Fliese richtig abschneiden zu können. So muss die Seite, die die Ecke berührt, gerade sein, damit man auf der anderen Seite weiterverlegen kann.

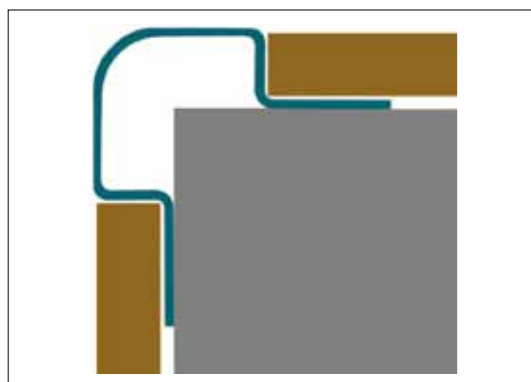

POSA ANGOLO ESTERNO

In caso di posa di un angolo esterno, arrivare a filo dell'angolo con la piastrella mosaicata tagliata in linea retta ed inserire il raccordo jolly.

Tiling external corners
When tiling an external corner, tile up to the corner with the mosaic-effect tile cut in a straight line and fit a universal connecting piece, sold in various colours and finishes (PVC, steel, aluminium).



Verlegen einer Außenecke

Beim Verlegen einer Außenecke mit gerade geschnittener Mosaikfliese nähert man sich der Ecke an und fügt ein in verschiedenen Farben und Ausführungen (PVC, Stahl, Aluminium) im Handel erhältliches Gehrungs-Verbindungsstück (Jolly) ein.

Pose angle externe
En cas de pose dans un angle externe, arriver à proximité de l'angle avec le carreau mosaïque coupé en ligne droite et insérer un raccord externe, disponible dans le commerce en différentes couleurs et finitions (PVC, acier, aluminium).

SOLUZIONI DI POSA TILING SOLUTIONS - SOLUTIONS DE POSE - VERLEGELÖSUNGEN



È possibile scegliere come terminare la parte superiore della parete posata:

- lasciando la piastrella integra (a)
- tagliando la piastrella in linea retta (b)
- aggiungendo il profilo in alluminio anodizzato (c)

There are various options for finishing off the top of a tiled wall:

- finish with a full tile (a)
- cut the tile with a straight line (b)
- fit an anodised aluminium edge (c)

Il est possible de choisir comment terminer la partie supérieure du mur carrelé:

- en laissant le carreau tel quel (a)
- en coupant le carreau en ligne droite (b)
- en ajoutant un profilé en aluminium anodisé (c)

Man kann wählen, wie man das Verlegen am oberen Wandende abschließt:

- indem man die Fliese ganz lässt (a)
- indem man die Fliese gerade schneidet (b)
- indem man ein Profil aus eloxiertem Aluminium einfügt (c)

LA STUCCATURA GROUTING - REMPLISSAGE DES JOINTS - DAS VERFUGEN



Per ottenere una stuccatura uniforme, l'acqua deve essere molto pulita, impiegata alla giusta temperatura ed i materiali utilizzati devono essere perfettamente puliti. Si può fugare con fuga cementizia tipo Mapei (Keracolor FF o Ultracolor Plus) o Technokolla (Tecnostuck 3.12) e similari. Si consiglia di miscelare lo stucco con additivo (tipo Fugolastic di Mapei) o similari, al posto dell'acqua, per aumentare il potere aggrappante della fuga. Oppure utilizzare uno stucco epossidico bicomponente tipo Kerapoxy di Mapei o Skycolors di Technokolla o similari. Prima dell'operazione di stuccatura, che si raccomanda di eseguire a temperatura ambiente superiore a 10°, deve essere leggermente inumidito tutto il supporto, compresi ovviamente i giunti interni, per prevenire la rapida essiccazione dello stucco. Lo stucco deve coprire tutta la superficie ceramica per ottenere una posa uniforme e prevenire potenziali infiltrazioni di liquidi. La malta deve essere posata su superfici non eccessivamente grandi e procedere per steps fino alla completa stuccatura del materiale.

To be sure you get even grouting results, you must use very clean water at the right temperature and the materials you use must also be perfectly clean. You can fill the joints using a cement-based grout like Mapei (Keracolor FF or Ultracolor Plus) or Technokolla (Tecnostuck 3.12) or similar products. We recommend mixing the grout with an additive (like Fugolastic by Mapei or a similar product) instead of water as this will increase the grip of the grout. Otherwise, use a dual-component epoxy grout like Kerapoxy by Mapei or Skycolors by Technokolla or similar products. Before filling the joints, which you should only attempt if the room temperature is above 10°C, dampen all of the support lightly, including the internal joints, to prevent the grout from drying out too quickly. The grout must cover all of the ceramic surface in order to ensure an even result and prevent potential infiltrations of liquids. Apply the mortar to a surface area that is not excessively large; work in steps until all of the tiled area has been grouted.

Pour un remplissage uniforme des joints, l'eau doit être très propre et à une température correcte, et les matériaux utilisés doivent également être parfaitement propres. Le remplissage des joints peut être effectué en utilisant le ciment-joint de type Mapei (Keracolor FF ou Ultracolor Plus) ou Technokolla (Tecnostuck 3.12) et produits similaires. Il est conseillé de mélanger le ciment-joint à un additif (de type Fugolastic de Mapei ou produits similaires) à la place de l'eau pour améliorer la prise du joint, ou d'utiliser un ciment-joint époxy bicomposant de type Kerapoxy de Mapei ou Skycolors de Technokolla ou produits similaires. Avant de procéder au remplissage des joints, qu'il est recommandé de réaliser à une température ambiante supérieure à 10°, l'ensemble du support doit être légèrement humidifié, y compris naturellement les joints internes, de façon à empêcher un séchage trop rapide du ciment-joint. Le ciment-joint doit couvrir toute la surface céramique de façon à obtenir une pose uniforme et à prévenir les infiltrations potentielles de liquides. Le mortier doit être posé sur des surfaces de dimensions raisonnables, en procédant par étapes jusqu'au remplissage complet.

Um ein gleichmäßiges Verfugen zu gewährleisten, muss das Wasser immer ganz sauber sein und die richtige Temperatur haben, außerdem müssen die verwendeten Materialien perfekt sauber sein. Zum Verfugen kann man den Zementmörtel des Typs Mapei (Keracolor FF oder Ultracolor Plus) oder Technokolla (Tecnostuck 3.12) und ähnliche verwenden. Es wird empfohlen, die Fugenmasse mit einem Zusatz (z.B. Fugolastic von Mapei oder ähnliches) anstelle des Wassers zu vermischen, um das Haftvermögen der Fuge zu verstärken. Man kann aber auch eine Zweikomponenten-Epoxydharz-Fugenmasse des Typs Kerapoxy von Mapei oder Skycolors von Technokolla oder ähnliche verwenden. Vor dem Verfugen, das immer bei einer Raumtemperatur über 10° ausgeführt werden sollte, muss man den gesamten Untergrund einschließlich der internen Fugen leicht anfeuchten, um zu vermeiden, dass die Fugenmasse zu schnell trocknet. Die Fugenmasse muss die gesamte Keramikfläche bedecken, um ein gleichmäßiges Ergebnis zu gewährleisten und der Gefahr des Eindringens von Flüssigkeiten vorzubeugen. Die Flächen, auf die man den Mörtel aufträgt, sollten nicht allzu groß sein: Schrittweise vorgehen, bis das gesamte Material verfugt ist.

LA PULIZIA CLEANING - NETTOYAGE - DIE REINIGUNG

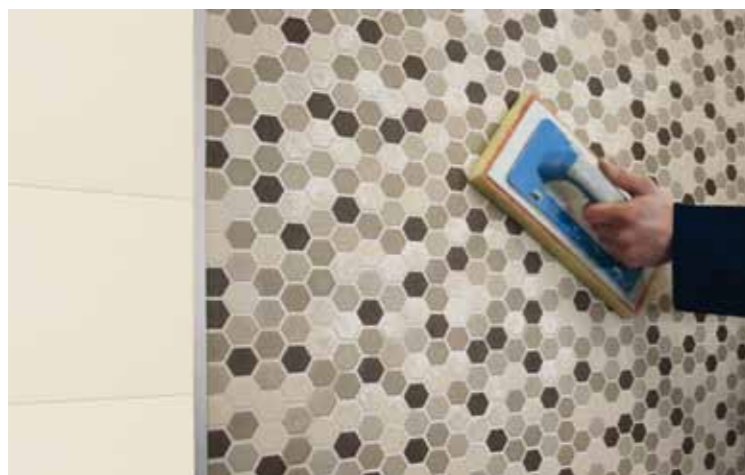

La rimozione dello stucco in eccesso deve avvenire dopo aver atteso il tempo necessario. Questo tempo deve essere calcolato in base alla malta e stucco utilizzato e non deve essere eccessivamente lungo in quanto, durante la pulizia, la sua eliminazione potrebbe graffiare la superficie dello smalto. Quando, dopo 10-20 minuti, la stuccatura perde plasticità e diventa opaca, si procede alla prima pulizia mediante la rimozione dell'eccesso di sigillante con una spugna umida e pulita. In seguito effettuare una pulizia a secco con un panno asciutto o con un feltro.

Dopo 36/48 ore sia piastrelle che fughe hanno completato la loro stagionatura e si procede alla pulizia finale mediante lavaggio della superficie con un acido ad azione tamponata. Si deve poi risciacquare con abbondante acqua pulita.

Sia per la prima pulizia, che viene eseguita alla fine del lavoro, che per le successive operazioni di manutenzione giornaliera, evitare prodotti acidi e aggressivi.

Remove the excess grout at the end of the required setting time. Calculate how long the setting time has to be based on the mortar and grout used: it should not be too long because this could result in you scratching the surface of the glaze when removing it during cleaning. When the grout becomes less elastic and turns opaque after 10-20 minutes, go ahead with the initial cleaning by removing the excess sealant using a clean, damp sponge. Afterwards, buff up the surface using a dry cloth or felt. The tiles and the grouting will be completely dry after 36/48 hours and you can go ahead and deep clean the surface using an acid-based buffered product. Then rinse with plenty of clean water.

Avoid using acidic or harsh cleaning products when cleaning after finishing tiling and for subsequent daily cleaning.

L'élimination de la colle en excès doit être effectuée après un temps d'attente. Ce temps doit être calculé en fonction du mortier et du ciment-joint utilisés. Il ne doit pas être excessivement long car, lors du nettoyage, son élimination pourrait rayer la surface de l'émail. Lorsque, après 10 à 20 minutes, le joint perd de sa plasticité et devient opaque, un premier nettoyage doit être réalisé en éliminant l'excédent de colle avec une éponge propre humidifiée. Effectuer ensuite un nettoyage à sec avec un linge sec ou un feutre. Les carreaux et les joints sont complètement secs après 36/48 heures. Il est alors possible de procéder au nettoyage final de la surface à l'aide d'un décapant acide. Rincer ensuite à l'eau propre abondante.

Tant pour le premier nettoyage effectué au terme du travail que pour les opérations futures d'entretien quotidien, éviter d'utiliser des produits acides et agressifs.

Die Entfernung der überschüssigen Fugenmasse darf erst nach der nötigen Wartezeit erfolgen. Diese Zeit muss je nach den verwendeten Mörteln und Fugenmassen berechnet werden und darf nicht allzu lange sein, da man sonst bei der Beseitigung während der Reinigung die Glasoberfläche zerkratzen könnte. Sobald die Fugenmasse nach 10-20 Minuten an Plastizität verliert und matt wird, beginnt man mit der Reinigung, indem man die überschüssige Fugenmasse mit einem sauberen, feuchten Schwamm entfernt. Danach mit einem trockenen Tuch oder Filz trocken reinigen. Nach 36-48 Stunden haben sowohl die Fliesen, als auch die Fugen ihren Reifungsprozess beendet und man kann die Endreinigung durchführen, indem man die Oberfläche mit einer gepufferten Säure wäscht. Danach ausreichend mit sauberem Wasser abspülen.

Sowohl bei dieser ersten Reinigung nach Abschluss der Arbeiten, als auch bei der folgenden täglichen Wartung den Einsatz von säurehaltigen und aggressiven Produkten vermeiden.

quark

Rivestimento in bicottura

Double-fired wall tiles
Revêtement biccuisson
Zweibrandverfahren Wandfliese

20x33,3 - 10x33,3 - 10x16,65 - 20x20
8"x13" - 4"x13" - 4"x6,5" - 8"x8"



Bianco

301101/32 14	301155/28 08	301103/46 59	301152/48 56
Galassia Bianco	Sirio Bianco	Odissea Bianco	Brick Odissea Bianco
20x33,3 18	20x20 27	10x33,3 36	10x16,65 72

Azzurro

301107/59 57	301147/59 57
Odissea Celeste	Brick Odissea Celeste
10x33,3 36	10x16,65 72

Nero

201371/03 64	301160/31 13	301104/59 57	301150/59 57
List. Quark Nero	Sirio Nero	Odissea Nero	Brick Odissea Nero
5x20 36	20x20 27	10x33,3 36	10x16,65 72

Gres Porcellanato Pavimenti consigliati / Suitable floor tiles / Carreaux pour sol coordonnés / Bodenfliesen-empfehlung

R02446/32 66	301618/32 66	R02400/33 77
Cristallo HR	Turchese HR	Nero HR
31x31 14	33,3x33,3 14	25x25 18

pesi e misure / weight and sizes / poids et mesures / Gewichte und Verpackungen							
dimensioni / sizes / dimensions / abmessungen	spessore / thickness / épaisseur / stärke	pz/collo / pcs/box / pc/boite / stk/ktn	mq/collo / sqm/box / m/boite / qm/ktn	kg/collo / kg/box / kg/boite / kg/ktn	colli/europal / boxes/europal / boites/europal / ktn/europal	mq/europal / sqm/europal / m/europal / qm/europal	kg/europal / kg/europal / kg/europal / kg/europal
Fondo 10x16,65	8 mm	72	1,20	18,50	34	40,8	629
Fondo 10x33,3	8 mm	36	1,20	18,50	68	81,60	1283
Fondo 20x20	8 mm	27	1,08	16,20	95	102,60	1564
Fondo 20x33,3	8 mm	18	1,20	18,50	68	81,60	1283

201321/09 28	500108/18 40	001050/13 50	001051/13 50	001055/16 51
List. Bullnose Odissea Bianco	Spigolo Bullnose Odissea Bianco	Astra A	Astra B	Pitagora Bianco
4x33,3 12	4x4 4	20x20 18	20x20 18	20x20 12

001065/10 31	201369/09 29
Cometa Quark Bianco	List. Astra
20x20 6	5x20 36

201323/09 28	500110/18 40	001066/10 31	001071/16 51
List. Bullnose Odissea Nero	Spigolo Bullnose Odissea Nero	Cometa Quark Nero	Queen Nero (misto 2 pz.)
4x33,3 12	4x4 4	20x20 6	20x20 12

Esempio di posa / Laying example / Exemple de pose / Vorbild der Verlegung





note / notes / notes / notes

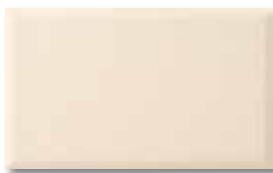

● Ad esaurimento verrà prodotto nel formato 31x31
Will be produced in the 31x31 size while stocks last / En cas d'épuisement, il sera produit dans le format 31x31 / Restbestand, wird in Zukunft im Format 31x31 hergestellt

pesi e misure / weight and sizes / poids et mesures / Gewichte und Verpackungen							
dimensioni / sizes / dimensions / abmessungen	spessore / thickness / épaisseur / stärke	pz/collo / pcs/box / pc/boite / stk/ktn	mq/collo / sqm/box / m/boite / qm/ktn	kg/collo / kg/box / kg/boite / kg/ktn	colli/europal / boxes/europal / boites/europal / ktn/europal	mq/europal / sqm/europal / m/europal / qm/europal	kg/europal / kg/europal / kg/europal / kg/europal
Pavimento HR 25x25	9 mm	18	1,125	21,30	80	90	1710
Pavimento HR 31x31	9 mm	14	1,35	24,00	72	97,20	1750
Pavimento HR 33,3x33,3	9 mm	14	1,55	28,50	48	74,40	1372



Beige

			
301102/32 14 ■	301156/28 08 ■	301108/46 59 ■	301151/48 56 ■
Galassia Beige	Sirio Beige	Odissea Beige	Brick Odissea Beige
20x33,3 18	20x20 27	10x33,3 36	10x16,65 72



Cacao





		
301158/31 13 ■	301106/59 57 ■	301148/59 57 ■
Sirio Cacao	Odissea Cacao	Brick Odissea Cacao
20x20 27	10x33,3 36	10x16,65 72





Rosso

		
301159/35 62 ■	301105/66 69 ■	301149/66 69 ■
Sirio Rosso	Odissea Rosso	Brick Odissea Rosso
20x20 27	10x33,3 36	10x16,65 72

Bordeaux

		
301161/35 62 ■	301153/66 69 ■	301154/66 69 ■
Sirio Bordeaux	Odissea Bordeaux	Brick Odissea Bordeaux
20x20 27	10x33,3 36	10x16,65 72

			
201322/09 28 ■	500109/18 40 ■	001069/10 31 ■	001056/16 51 ■
List. Bullnose Odissea Beige	Spigolo Bullnose Odissea Beige	Cometa Quark Beige	Pitagora Beige
4x33,3 12	4x4 4	20x20 6	20x20 12

			
001070/10 31 ■	201372/03 64 ■	201358/14 38 ■	
Cometa Quark Cacao	List. Quark Cacao	Sinfonia Beige (misto 2 pz)	
20x20 6	5x20 36	10x33,3 12	

	
001067/10 31 ■	201370/03 64 ■
Cometa Quark Rosso	List. Quark Rosso
20x20 6	5x20 36

			
001068/10 31 ■	201373/03 64 ■	001074/16 51 ■	
Cometa Quark Bordeaux	List. Quark Bordeaux	Queen Bordeaux (misto 2 pz.)	
20x20 6	5x20 36	20x20 12	





note / notes / notes / anmerkungen

★ Questi prodotti potrebbero presentare la caratteristica puntinatura del rosso al selenio.
These products may present the typical dots of red colour obtained from Selenium / Ces produits pourraient présenter la piqûre caractéristique du rouge de sélénium / Diese Produkte könnten die typischen roten Selenium-Farbkörner aufweisen

pesi e misure / weight and sizes / poids et mesures / Gewichte und Verpackungen

dimensioni sizes dimensions abmessungen	spessore thickness épaisseur stärke	pz/collo pcs/box pc/boite stk/ktn	mq/collo sqm/box m/boite qm/ktn	kg/collo kg/box kg/boite kg/ktn	colli/eurol box/eurol boites/eurol ktn/eurol	mq/eurol sqm/eurol m/eurol qm/eurol	kg/eurol kg/eurol kg/eurol kg/eurol
Fondo 10x16,65	8 mm	72	1,20	18,50	34	40,8	629
Fondo 10x33,3	8 mm	36	1,20	18,50	68	81,60	1283
Fondo 20x20	8 mm	27	1,08	16,20	95	102,60	1564
Fondo 20x33,3	8 mm	18	1,20	18,5	68	81,60	1283
Pavimento HR 30,5x30,5	9 mm	14	1,30	23,10	72	93,60	1680
Pavimento HR 31x31	9 mm	14	1,35	24,00	72	97,20	1750

Gres Porcellanato Pavimenti consigliati / Suitable floor tiles / Carreaux pour sol coordonnés / Bodenfliesen-empfehlung

			
R02447/32 66 ■	R02454/32 66 ■	R02453/33 77 ■	R02456/40 ★ 15 ■
Corda HR	Moka HR	Granato HR	Karmin HR
30,5x30,5 14	30,5x30,5 14	30,5x30,5 14	31x31 18



TT0828 Espositore serie Quark

cm 38x115x143 1

Pannelli cm 38x118 5



TTP025 Pannello Sinottico serie Quark

cm 100x200

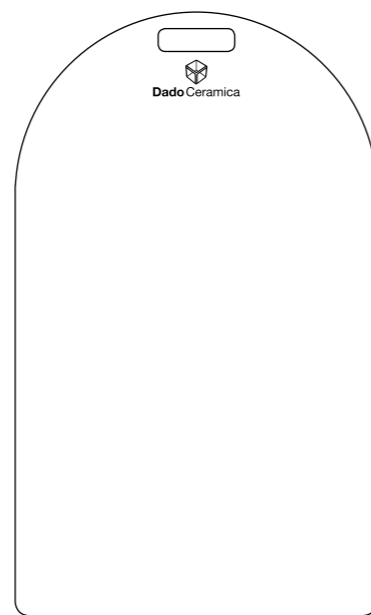

Faesite serie Quark

cm 47x80

venice

Rivestimento in bicottura
 Double-fired wall tiles
 Revêtement bicuisson
 Zweibrandverfahren Wandfliese

20x33,3
 8"x13"



Pavimenti consigliati vedi serie Rovere pag. 89
 Recommended flooring - see Rovere series, page 89 / Revêtements de sol conseillés
 voir série Rovere page 89 / Empfohlene Bodenbeläge siehe Serie Rovere S. 89

Colori / Colour / Couleurs / Farben

301092/31 13	301337/35 62	301392/35 62	301391/35 62	301241/35 62
Venice Bianco	Venice Beige	Venice Tortora	Venice Marrone	Venice Lilla
20x33,3 18	20x33,3 18	20x33,3 18	20x33,3 18	20x33,3 18
302660/33 55	302661/37 54	302662/37 54	302663/37 54	302664/37 54
L2 Venice Bianco	L2 Venice Beige	L2 Venice Tortora	L2 Venice Marrone	L2 Venice Lilla
20x33,3 18	20x33,3 18	20x33,3 18	20x33,3 18	20x33,3 18
301121/186 73	301367/186 73	301394/186 73	301393/186 73	301242/186 73
Mosaico Venice Bianco	Mosaico Venice Beige	Mosaico Venice Tortora	Mosaico Venice Marrone	Mosaico Venice Lilla
33,3x33,3 (su rete) 9	33,3x33,3 (su rete) 9	33,3x33,3 (su rete) 9	33,3x33,3 (su rete) 9	33,3x33,3 (su rete) 9

Colori / Colour / Couleurs / Farben

301093/35 62	301094/35 62	301095/35 62	301096/35 62
Venice Fuxia	Venice Arancio	Venice Azzurro	Venice Smeraldo
20x33,3 18	20x33,3 18	20x33,3 18	20x33,3 18
302665/37 54	302666/37 54	302667/37 54	302668/37 54
L2 Venice Fuxia	L2 Venice Arancio	L2 Venice Azzurro	L2 Venice Smeraldo
20x33,3 18	20x33,3 18	20x33,3 18	20x33,3 18
301122/186 73	301123/186 73	301124/186 73	301125/186 73
Mosaico Venice Fuxia	Mosaico Venice Arancio	Mosaico Venice Azzurro	Mosaico Venice Smeraldo
33,3x33,3 (su rete) 9	33,3x33,3 (su rete) 9	33,3x33,3 (su rete) 9	33,3x33,3 (su rete) 9

Gres Porcellanato Pavimenti consigliati / Suitable floor tiles / Carreaux pour sol coordonnés / Bodenfliesen-empfehlung

R02446/32 66	R02447/32 66	R02548/32 66	R02454/32 66	301617/32 66
Cristallo HR PEI IV	Corda HR PEI IV	Tortora HR PEI IV	Moka HR PEI IV	Lilla HR PEI IV
31x31 14	30,5x30,5 14	30,5x30,5 14	30,5x30,5 14	33,3x33,3 14

R02440/32 66	R02198/40 15	301618/32 66	R02458/33 77
Fuxia HR PEI IV	Melon HR PEI III	Turchese HR PEI IV	Acquamarina HR PEI IV
30,5x30,5 14	25x25 18	33,3x33,3 14	30,5x30,5 14

note / notes / notes / anmerkungen

* Questi prodotti potrebbero presentare la caratteristica puntinatura del rosso al selenio.
 These products may present the typical dots of red colour obtained from Selenium / Ces produits pourraient présenter la piqure caractéristique du rouge de sélénium / Diese Produkte könnten die typischen roten Selenium-Farbkörner aufweise.

note / notes / notes / anmerkungen

● Ad esaurimento verrà prodotto nel formato 31x31
 Will be produced in the 31x31 size while stocks last / En cas d'épuisement, il sera produit dans le format 31x31 / Restbestand, wird in Zukunft im Format 31x31 hergestellt



















pesi e misure / weight and sizes / poids et mesures / Gewichte und Verpackungen

dimensioni sizes dimensions abmessungen	spessore thickness épaisseur stärke	pz/collo pcs/box pc/boite stk/ktn	mq/collo sqm/box m/boite qm/ktn	kg/collo kg/box kg/boite kg/ktn	colli/europal box/europal boites/europal ktn/europal	mq/europal sqm/europal m/europal qm/europal	kg/europal kg/europal kg/europal kg/europal
Fondo 20x33,3 - Fondo L2 20x33,3	8 mm	18	1,20	17,3	68	81,60	1200
Mosaico 33,3x33,3	8 mm	9	1	12			

pesi e misure / weight and sizes / poids et mesures / Gewichte und Verpackungen

dimensioni sizes dimensions abmessungen	spessore thickness épaisseur stärke	pz/collo pcs/box pc/boite stk/ktn	mq/collo sqm/box m/boite qm/ktn	kg/collo kg/box kg/boite kg/ktn	colli/europal box/europal boites/europal ktn/europal	mq/europal sqm/europal m/europal qm/europal	kg/europal kg/europal kg/europal kg/europal
Pavimento HR 25x25	9 mm	8	1,125	21,30	80	90	1710
Pavimento HR 30,5x30,5	9 mm	14	1,30	23,10	72	93,60	1680
Pavimento HR 31x31	9 mm	14	1,35	24,00	72	97,20	1750
Pavimento HR 33,3x33,3	9 mm	14	1,55	28,50	48	74,40	1372

Decori / Decorations / Décorations / Dekors

				
001029/06 18 ■ Surf Bianco 10x33,3 6	001091/06 18 ■ Surf Beige 10x33,3 6	001099/06 18 ■ Surf Tortora 10x33,3 6	001098/06 18 ■ Surf Marrone 10x33,3 6	
				
001073/06 18 ■ Surf Lilla 10x33,3 6	001033/06 18 ■ Surf Fuxia 10x33,3 6	001032/06 18 ■ Surf Arancio 10x33,3 6	001030/06 18 ■ Surf Azzurro 10x33,3 6	001031/06 18 ■ Surf Smeraldo 10x33,3 6
				
201403/25 04 ■ List. Boemia Lilla 3x33,3 12	201315/25 04 ■ List. Boemia Fuxia 3x33,3 12	201291/25 04 ■ List. Boemia Arancio 3x33,3 12	201292/25 04 ■ List. Boemia Azzurro 3x33,3 12	201293/25 04 ■ List. Boemia Smeraldo 3x33,3 12
				
201335/11 33 ■ List. Windy Fuxia 5x33,3 12	201336/11 33 ■ List. Windy Arancio 5x33,3 12	201337/11 33 ■ List. Windy Azzurro 5x33,3 12	201338/11 33 ■ List. Windy Smeraldo 5x33,3 12	





TT0775 Espositore serie Venice

cm 38x115x143	1
Pannelli cm 38x118	6

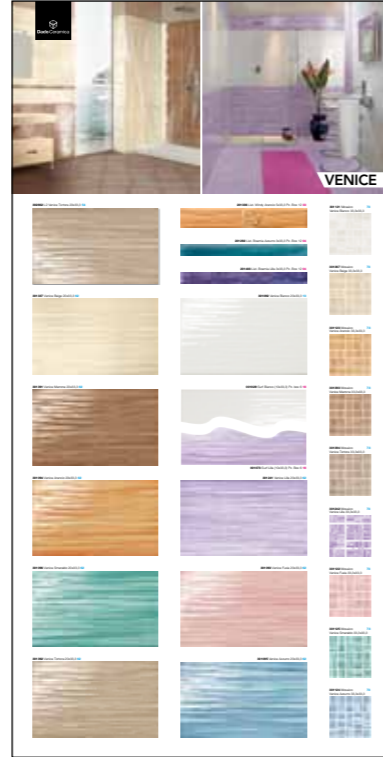

TTP026 Pannello Sinottico
serie Venice
cm 100x200

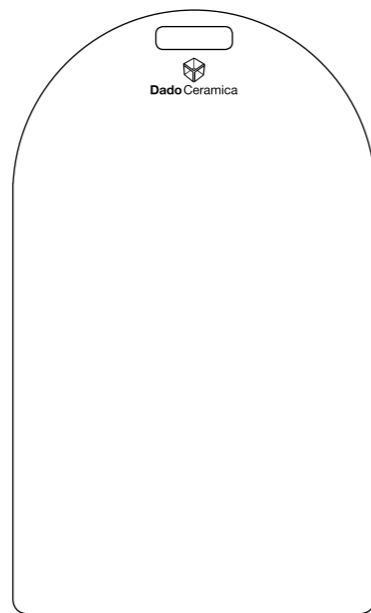

Faesite serie Venice
cm 80x47













1000 tracce

Rivestimento in bicottura
Double-fired wall tiles
Revêtement bicuisson
Zweibrandverfahren Wandfliese





20x33,3
8"x13"





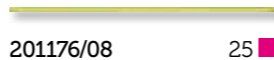

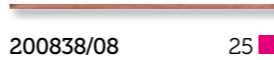
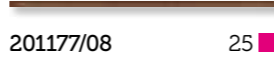

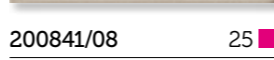
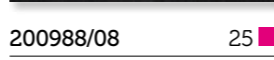







Colori / Colour / Couleurs / Farben

			
300902/30 11 ■	300907/32 14 ■	300903/32 14 ■	300904/32 14 ■
Mille Bianco	Mille Giallo	Mille Verde	Mille Azzurro
20x33,3 18	20x33,3 18	20x33,3 18	20x33,3 18
			
300905/32 14 ■	300906/32 14 ■	301053/32 14 ■	301032/32 14 ■
Mille Rosa	Mille Caffè	Mille Grigio	Mille Nero
20x33,3 18	20x33,3 18	20x33,3 18	20x33,3 18
			
302646/33 55 ■	302647/37 54 ■	302648/37 54 ■	302649/37 54 ■
L2 Mille Bianco	L2 Mille Giallo	L2 Mille Verde	L2 Mille Azzurro
20x33,3 18	20x33,3 18	20x33,3 18	20x33,3 18
			
302650/37 54 ■	302651/37 54 ■	302652/37 54 ■	302653/37 54 ■
L2 Mille Rosa	L2 Mille Caffè	L2 Mille Grigio	L2 Mille Nero
20x33,3 18	20x33,3 18	20x33,3 18	20x33,3 18

Bacchette / Liners
 Baguettes / Leisten

							
200923/08 25 ■	201176/08 25 ■	200839/08 25 ■	200838/08 25 ■	201177/08 25 ■	201178/09 26 ■	200841/08 25 ■	200988/08 25 ■
Bacchetta Soleado	Bacchetta Verde	Bacchetta Turchese	Bacchetta Fuxia	Bacchetta Caffè	Bacchetta Oro	Bacchetta Grigio	Bacchetta Africa
0,6x33,3 36	0,6x33,3 36	0,6x33,3 36	0,6x33,3 36	0,6x33,3 36	0,6x33,3 36	0,6x33,3 36	0,6x33,3 36

Colori / Colour / Couleurs / Farben





			
301036/94 84 ■	301038/94 84 ■	301033/94 84 ■	301037/94 84 ■
Mille Lustro Giallo	Mille Lustro Verde	Mille Lustro Azzurro	Mille Lustro Rosa
20x33,3 16	20x33,3 16	20x33,3 16	20x33,3 16
			
201265/06 19 ■	201266/06 19 ■	201264/06 19 ■	201262/06 19 ■
Bacchetta Lustro Giallo	Bacchetta Lustro Verde	Bacchetta Lustro Azzurro	Bacchetta Lustro Rosa
2x33,3 48	2x33,3 48	2x33,3 48	2x33,3 48
			
301035/94 84 ■	301054/94 84 ■	301024/94 84 ■	
Mille Lustro Caffè	Mille Lustro Grigio	Mille Lustro Nero	
20x33,3 16	20x33,3 16	20x33,3 16	
			
201263/06 19 ■	201268/06 19 ■	201267/06 19 ■	
Bacchetta Lustro Caffè	Bacchetta Lustro Grigio	Bacchetta Lustro Nero	
2x33,3 48	2x33,3 48	2x33,3 48	

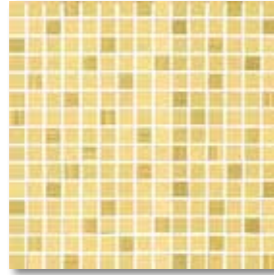
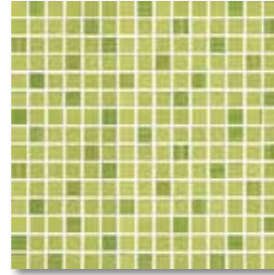

pesi e misure / weight and sizes / poids et mesures / Gewichte und Verpackungen

dimensioni sizes dimensions abmessungen	spessore thickness épaisseur stärke	pz/collo pcs/box pc/boite stk/ktn	mq/collo sqm/box m/boite qm/ktn	kg/collo kg/box kg/boite kg/ktn	colli/eurolpal box/eurolpal boites/eurolpal ktn/eurolpal	mq/eurolpal sqm/eurolpal m/eurolpal qm/eurolpal	kg/eurolpal kg/eurolpal kg/eurolpal kg/eurolpal
Fondo 20x33,3	8 mm	18	1,20	17,3	68	81,60	1200
Fondo L2 20x33,3	8 mm	18	1,20	17,3	68	81,60	1200
Fondo Lustro 20x33,3	8 mm	16	1,07	16,45	68	72,76	1120

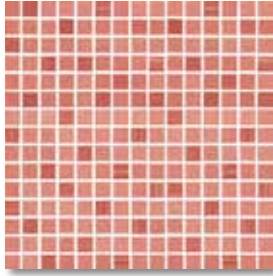

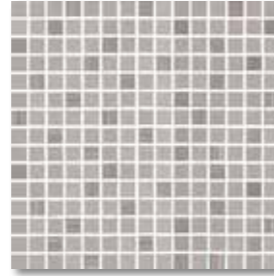
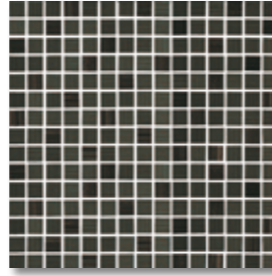









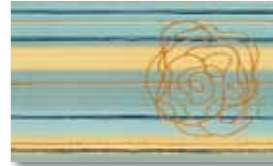





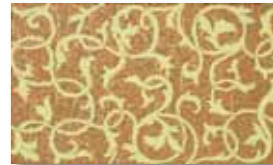

Mosaici / Mosaics / Mosaïques / Mosaik

			
301025/186 73 ■ Mosaico Mille Bianco 33,3x33,3 (su rete) 9	301029/186 73 ■ Mosaico Mille Giallo 33,3x33,3 (su rete) 9	301030/186 73 ■ Mosaico Mille Verde 33,3x33,3 (su rete) 9	301026/186 73 ■ Mosaico Mille Azzurro 33,3x33,3 (su rete) 9
			
301027/186 73 ■ Mosaico Mille Rosa 33,3x33,3 (su rete) 9	301028/186 73 ■ Mosaico Mille Caffè 33,3x33,3 (su rete) 9	301060/186 73 ■ Mosaico Mille Grigio 33,3x33,3 (su rete) 9	301031/186 73 ■ Mosaico Mille Nero 33,3x33,3 (su rete) 9

Gres Porcellanato Pavimenti consigliati / Suitable floor tiles / Carreaux pour sol coordonnés / Bodenfliesen-empfehlung

			
R02449/33 77 ■ Soleado HR PEI IV 30,5x30,5 14	R01944/32 ● 66 ■ Muschio HR PEI IV 25x25 18	301618/32 66 ■ Turchese HR PEI IV 33,3x33,3 14	R02440/32 66 ■ Fuxia HR PEI IV 30,5x30,5 14
			
R02454/32 66 ■ Moka HR PEI IV 30,5x30,5 14	R02445/32 66 ■ Grigio HR PEI IV 31x31 14	R02400/33 ● 77 ■ Nero HR PEI III 25x25 18	

Decor / Decorations / Décorations / Dekors

				
000938/24 03 ■ Orbita Azzurro A 20x33,3 12	000979/27 46 ■ Orme Nero A 20x33,3 12	000940/27 46 ■ Orme Rosa A 20x33,3 12	000947/27 46 ■ Orme Azzurro A 20x33,3 12	000937/37 54 ■ Astrale Caffè 20x33,3 12
				
000939/24 03 ■ Orbita Azzurro B 20x33,3 12	000980/27 46 ■ Orme Nero B 20x33,3 12	000941/27 46 ■ Orme Rosa B 20x33,3 12	000948/27 46 ■ Orme Azzurro B 20x33,3 12	000935/37 54 ■ Astrale Verde 20x33,3 12
				
000944/24 03 ■ Orbita Giallo A 20x33,3 12	000988/20 45 ■ Segni Grigio 20x33,3 12	000932/20 45 ■ Segni Rosa 20x33,3 12	000933/20 45 ■ Segni Azzurro 20x33,3 12	000936/37 54 ■ Astrale azzurro 20x33,3 12
				
000945/24 03 ■ Orbita Giallo B 20x33,3 12	000989/59 la comp. 57 ■ Comp. Cerchi Grigio 20x33,3 12	000934/20 45 ■ Segni Verde 20x33,3 12	001209/15 39 ■ Kitchen (misto 2 pz.) 20x33,3 6	201175/23 48 ■ Listello Tracce 10x33,3 12
				
201278/13 37 ■ List. Cerchi Grigio 8x33,3 24				

note / notes / notes / anmerkungen

● Ad esaurimento verrà prodotto nel formato 31x31
Will be produced in the 31x31 size while stocks last / En cas d'épuisement, il sera produit dans le format 31x31 / Restbestand, wird in Zukunft im Format 31x31 hergestellt

pesi e misure / weight and sizes / poids et mesures / Gewichte und Verpackungen

dimensioni sizes dimensions abmessungen	spessore thickness épaisseur stärke	pz/collo pcs/box pc/boite stk/ktn	mq/collo sqm/box m/boite qm/ktn	kg/collo kg/box kg/boite kg/ktn	colli/europal box/europal boites/europal ktn/europal	mq/europal sqm/europal m/europal qm/europal	kg/europal kg/europal kg/europal kg/europal
Mosaico 33,3x33,3	8 mm	9	1	12			
Pavimento HR 25x25	9 mm	18	1,125	21,30	80	90	1710
Pavimento HR 30,5x30,5	9 mm	14	1,30	23,10	72	93,60	1680
Pavimento HR 31x31	9 mm	14	1,35	24,00	72	97,20	1750
Pavimento HR 33,3x33,3	9 mm	14	1,55	28,50	48	74,40	1372



TT0670 Espositore serie 1000tracce

cm 38x115x143	1
Pannelli cm 38x118	6



TTP016 Pannello Sinottico serie 1000tracce

cm 100x200

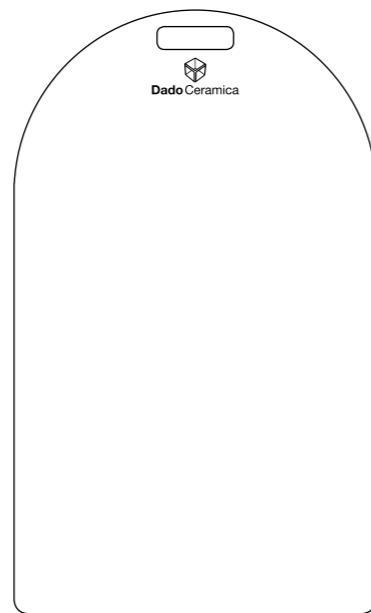

Faesite serie 1000tracce

cm 47x80

rock

Rivestimento in bicottura
 Double-fired wall tiles
 Revêtement bicuisson
 Zweibrandverfahren Wandfliese

12,5x33,3 - 25x33,3
5"x13" - 10"x13"



Avorio



300974/29 10
Lastra Avorio
25x33,3 18



300962/38 49
Rock Avorio
12,5x33,3 24



300993/80 70
Mosaico Rock Avorio
12,5x33,3 24

Beige



300963/40 15
Rock Beige
12,5x33,3 24



300990/80 70
Mosaico Rock Beige
12,5x33,3 24

Tabacco



300964/48 56
Rock Tabacco
12,5x33,3 24



300994/80 70
Mosaico Rock Tabacco
12,5x33,3 24

Decori / Decorations / Décorations / Dekors



201252/18 41
Florim Tabacco (misto 2 pz.)
12,5x33,3 12



201243/42 85
Clink Tabacco
10x33,3 12



201246/12 36
Bacchetta Strass Tabacco
1,5x33,3 36



201247/18 41
Bacchetta Okton
0,7x33,3 30

Gres Porcellanato Pavimenti consigliati / Suitable floor tiles / Carreaux pour sol coordonnés / Bodenfliesen-empfehlung



R02384/27 91
Polvere HR PEI IV
31x31 14

R02405/35 96
Polvere HR PEI IV
31x62 7

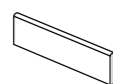

Battiscopa 7,5x31 46
R02396/04 Polvere 47
R02397/04 Terra 47
Battiscopa 7,2x62 20
R02416/07 Polvere 22
R02427/07 Terra 22

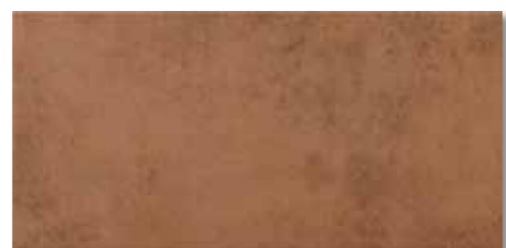

R02408/35 96
Terra HR PEI IV
31x62 7

R02382/27 91
Terra HR PEI IV
31x31 14

pesi e misure / weight and sizes / poids et mesures / Gewichte und Verpackungen							
dimensioni sizes dimensions abmessungen	spessore thickness épaisseur stärke	pz/collo pcs/box pc/boite stk/ktn	mq/collo sqm/box m/boite qm/ktn	kg/collo kg/box kg/boite kg/ktn	colli/europal box/europal boites/europal ktn/europal	mq/europal sqm/europal m/europal qm/europal	kg/europal kg/europal kg/europal kg/europal
Fondo 12,5x33,3	8 mm	24	1	14	60	60	840
Fondo 25x33,3	8 mm	18	1,50	20	51	76,50	1020
Mosaico 12,5x33,3	8 mm	24	1	14	60	60	865
Pavimento HR 31x31	9 mm	14	1,35	22	72	97,20	1600
Pavimento HR 31x62	9 mm	7	1,35	22	60	81	1340

Perla



300982/29 10
Lastra Perla
25x33,3 18



300967/38 49
Rock Perla
12,5x33,3 24



300995/80 70
Mosaico Rock Perla
12,5x33,3 24

Cemento



300966/40 15
Rock Cemento
12,5x33,3 24



300991/80 70
Mosaico Rock Cemento
12,5x33,3 24

Antracite



300965/48 56
Rock Antracite
12,5x33,3 24

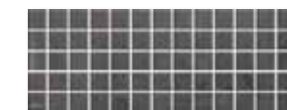

300992/80 70
Mosaico Rock Antracite
12,5x33,3 24

Decori / Decorations / Décorations / Dekors



201251/18 41
Florim Antracite (misto 2 pz.)
12,5x33,3 12



201244/42 85
Clink Antracite
10x33,3 12



201253/27 46
Fever
12,5x33,3 12



201245/12 36
Bacchetta Strass Cemento
1,5x33,3 36



201248/06 21
Bacchetta Titanium
0,6x33,3 30

Gres Porcellanato Pavimenti consigliati / Suitable floor tiles / Carreaux pour sol coordonnés / Bodenfliesen-empfehlung



R02381/27 91
Carbone HR PEI IV
31x31 14

R02406/35 96
Carbone HR PEI IV
31x62 7

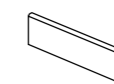

Battiscopa 7,5x31 46
R02399/04 Carbone 47
R02398/04 Ghiaia 47
Battiscopa 7,2x62 20
R02425/07 Carbone 22
R02426/07 Ghiaia 22



R02407/35 96
Ghiaia HR PEI IV
31x62 7

R02383/27 91
Ghiaia HR PEI IV
31x31 14

note / notes / notes / anmerkungen

12,5x33,3 modulare tagliato dal 25x33,3 preinciso
12,5x33,3 module cut from 25x33,3 precut / 12,5x33,3 module coupé du 25x33,3 pré-coupé / 12,5x33,3 modul geschnitten vom 25x33,3 Vorgeschnitten.

Per la posa del 12,5x33,3 in abbinamento e non al 25x33,3 ed al mosaico, è necessaria una fuga di almeno 2 mm.
For the laying of the 12,5x33,3 tiles it is advisable to leave a joint of at least 2 mm, especially when used with 25x33,3 tiles and with mosaics.
Pour la pose du format 12,5x33,3, spécialement coordonné au 25x33,3 et à la mosaïque, il est nécessaire un joint d'au moins 2 mm.
Für die Verlegung der 12,5x33,3 Fliesen, im besonderen mit den Fliesen 25x33,3 und dem Mosaik ist eine Fuge von 2 mm notwendig.



TT0733 Espositore serie Rock
 cm 38x115x143 1
 Pannelli cm 38x118 6



TTP021 Pannello Sinottico serie Rock
 cm 100x200

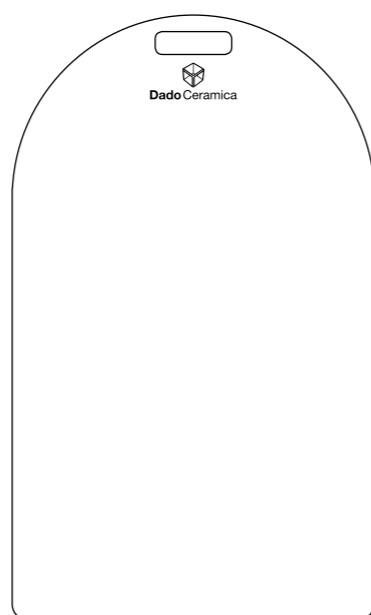

Faesite serie Rock
 cm 47x80



beauty matt

Rivestimento in bicottura
 Double-fired wall tiles
 Revêtement bicuisson
 Zweibrandverfahren Wandfliese

12,5x33,3 - 25x33,3
5"x13" - 10"x13"



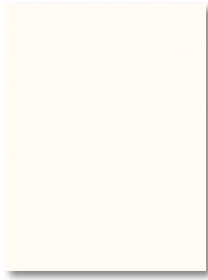

Spuma

		
300456/28 08 ■	300720/38 49 ■	201034/09 29 ■
Sabbia	Matt Spuma	List. Mix Lilla
25x33,3 18	12,5x33,3 24	2x33,3 24

Gres Porcellanato

R02446/32 66 ■
Cristallo HR PEI IV
31x31 14

Caffè

		
300704/48 56 ■	000891/20 45 ■	201033/09 29 ■
Matt Caffè	Grafico Caffè	List. Mix Caffè
12,5x33,3 24	12,5x33,3 12	2x33,3 24

Gres Porcellanato





R02454/32 66 ■
Moka HR PEI IV
30,5x30,5 14

Rimmel

300783/40 15 ■
Matt Rimmel
12,5x33,3 24





R02445/32 66 ■
Grigio HR PEI IV
31x31 14

Naranja *

		
300703/54 74 ■	000889/20 45 ■	201032/09 29 ■
Matt Naranja	Grafico Naranja	List. Mix Naranja
12,5x33,3 24	12,5x33,3 12	2x33,3 24





R02198/40 ● 15 ■
Melon HR PEI III
25x25 18

Beige

		
300698/31 13 ■	300702/40 15 ■	000888/20 45 ■
Matt Sahara	Matt Beige	Cady
25x33,3 18	12,5x33,3 24	12,5x33,3 12

R02447/32 66 ■
Corda HR PEI IV
30,5x30,5 14

Pernod

		
300781/48 56 ■	000910/20 45 ■	201092/09 29 ■
Matt Pernod	Grafico Pernod	List. Mix Pernod
12,5x33,3 24	12,5x33,3 12	2x33,3 24

	
R02457/33 77 ■	R02288/33 ● 77 ■
Avion HR PEI IV	Avion HR PEI IV
30,5x30,5 14	25x25 18

pesi e misure / weight and sizes / poids et mesures / Gewichte und Verpackungen								
dimensioni sizes dimensions abmessungen	spessore thickness épaisseur stärke	pz/collo pcs/box pc/boite stk/ktn	mq/collo sqm/box m/boite qm/ktn	kg/collo kg/box kg/boite kg/ktn	colli/europol box/europol boites/europol ktn/europol	mq/europol sqm/europol m/europol qm/europol	kg/europol kg/europol kg/europol kg/europol	
Fondo 12,5x33,3	8 mm	24	1	14	60	60	840	
Fondo 25x33,3	7,6 mm	18	1,5	20	51	76,5	1020	
Pavimento HR 25x25	9 mm	18	1,125	21,30	80	90	1710	
Pavimento HR 30,5x30,5	9 mm	14	1,30	23,10	72	93,6	1680	
Pavimento HR 31x31	9 mm	14	1,35	24,00	72	97,20	1750	

note / notes / notes / anmerkungen

12,5x33,3 modulare tagliato dal 25x33,3 preinciso
 12,5x33,3 module cut from 25x33,3 precut / 12,5x33,3 module coupé du 25x33,3 pré-coupé / 12,5x33,3 modul geschnitten vom 25x33,3 Vorgeschnitten.

Per la posa del 12,5x33,3 in abbinamento e non al 25x33,3 ed al mosaico, è necessaria una fuga di almeno 2 mm.
 For the laying of the 12,5x33,3 tiles it is advisable to leave a joint of at least 2 mm, especially when used with 25x33,3 tiles and with mosaics.
 Pour la pose du format 12,5x33,3, spécialement coordonné au 25x33,3 et à la mosaïque, il est nécessaire un joint d'au moins 2 mm.
 Für die Verlegung der 12,5x33,3 Fliesen, im besonderen mit den Fliesen 25x33,3 und dem Mosaik ist eine Fuge von 2 mm notwendig.

* **Questi prodotti potrebbero presentare la caratteristica puntinatura del rosso al selenio.**
 These products may present the typical dots of red colour obtained from Selenium / Ces produits pourraient présenter la piqûre caractéristique du rouge de sélénium / Diese Produkte könnten die typischen roten Selenium-Farbkörner aufweisen

● **Ad esaurimento verrà prodotto nel formato 31x31**
 Will be produced in the 31x31 size while stocks last / En cas d'épuisement, il sera produit dans le format 31x31 / Restbestand, wird in Zukunft im Format 31x31 hergestellt

Felce



300705/48 56 ■ 201048/09 29 ■
Matt Felce List. Mix Felce
12,5x33,3 24 □ 2x33,3 24 □

Gres Porcellanato

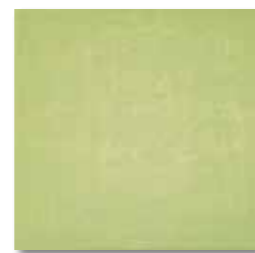

R01944/32 ● 66 ■
Muschio HR PEI IV
25x25 18 □

Marea



300706/48 56 ■ 201035/09 29 ■
Matt Marea List. Mix Marea
12,5x33,3 24 □ 2x33,3 24 □



301618/32 66 ■
Turchese HR PEI IV
33,3x33,3 14 □

Antracite



300782/48 56 ■ 000911/20 45 ■ 201091/09 29 ■
Matt Antracite Grafico Antracite List. Mix Antracite
12,5x33,3 24 □ 12,5x33,3 12 □ 2x33,3 24 □



R02442/32 66 ■
Ghisa HR PEI IV
30,5x30,5 14 □

note / notes / notes / notes

12,5x33,3 modulare tagliato dal 25x33,3 preinciso
12,5x33,3 module cut from 25x33,3 precut / 12,5x33,3 module coupé du 25x33,3 précoupé / 12,5x33,3 modul geschnitten vom 25x33,3 Vorgeschnitten.

Per la posa del 12,5x33,3 in abbinamento e non al 25x33,3 ed al mosaico, è necessaria una fuga di almeno 2 mm.
For the laying of the 12,5x33,3 tiles it is advisable to leave a joint of at least 2 mm, especially when used with 25x33,3 tiles and with mosaics. / Pour la pose du format 12,5x33,3, spécialement coordonné au 25x33,3 et à la mosaïque, il est nécessaire un joint d'au moins 2 mm. / Fuer die Verlegung der 12,5x33,3 Fliesen, im besonderen mit den Fliesen 25x33,3 und dem Mosaik ist eine Fuge von 2 mm notwendig.

● Ad esaurimento verrà prodotto nel formato 31x31
Will be produced in the 31x31 size while stocks last / En cas d'épuisement, il sera produit dans le format 31x31 / Restbestand, wird in Zukunft im Format 31x31 hergestellt

pesi e misure / weight and sizes / poids et mesures / Gewichte und Verpackungen

dimensioni sizes dimensions abmessungen	spessore thickness épaisseur stärke	pz/collo pcs/box pc/boite stk/ktn	mq/collo sqm/box m/boite qm/ktn	kg/collo kg/box kg/boite kg/ktn	colli/euopal box/euopal boites/euopal ktn/euopal	mq/euopal sqm/euopal m/euopal qm/euopal	kg/euopal kg/euopal kg/euopal kg/euopal
Fondo 12,5x33,3	8 mm	24	1	14	60	60	840
Fondo 25x33,3	76 mm	18	1,5	20	51	76,5	1020
Pavimento HR 25x25	9 mm	18	1,125	21,30	80	90	1710
Pavimento HR 30,5x30,5	9 mm	14	1,30	23,10	72	93,6	1680
Pavimento HR 33,3x33,3	9 mm	14	1,55	28,50	48	74,40	1372

Fondi / Base tiles / Fonds / Grundfliesen



300851/91 75 ■
Riflex Beige
25x33,3 18 □



300852/113 71 ■
Flexy Beige
12,5x33,3 22 □
201173/06 19 ■
Flexy Beige
12,5x33,3 22 □



300853/91 75 ■
Riflex Spuma
25x33,3 18 □



300854/113 71 ■
Flexy Spuma
12,5x33,3 22 □
201174/06 19 ■
Flexy Spuma
12,5x33,3 22 □

Decori / Decorations / Décorations / Dekors



201099/28 09 ■
Autunno (misto 4 pz.)
12,5x33,3 12 □

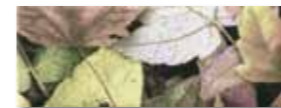

201055/13 37 ■
Piper
12,5x33,3 12 □

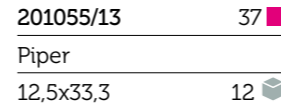

201064/14 38 ■
Summer
11x33,3 12 □



000915/26 06 ■
Ricamo Antracite
25x33,3 12 □



201107/15 39 ■
List. Perlage (misto 2 pz.)
6x33,3 12 □



201108/18 40 ■
Perlage
12,5x33,3 12 □



000914/26 06 ■
Ricamo Pernod
25x33,3 12 □



000890/20 45 ■
Grafico Lilla
12,5x33,3 12 □



200863/18 40 ■
Essenza (misto 2 pz.)
12,5x33,3 12 □



201063/30 11 ■
Florance
12,5x33,3 12 □

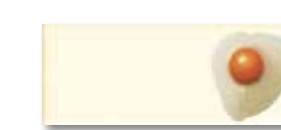

201079/18 41 ■
Breakfast A
12,5x33,3 12 □



201080/18 41 ■
Breakfast B
12,5x33,3 12 □

note / notes / notes / anmerkungen

⚡ **Attenzione!! Consultare l'istruzione per la posa contenuta all'interno della scatola del prodotto.**
Please note!! Refer to the installation instructions contained in the product packaging. / Attention!! Consulter le mode d'emploi pour la pose, contenu dans la boîte du produit. / Achtung!! Die Verlegeanleitungen in der Verpackung beachten.



TT0557 Espositore serie Beauty Matt

cm 38x115x143	1
Pannelli cm 38x118	6



TTP004 Pannello Sinottico serie Beauty Matt

cm 100x200

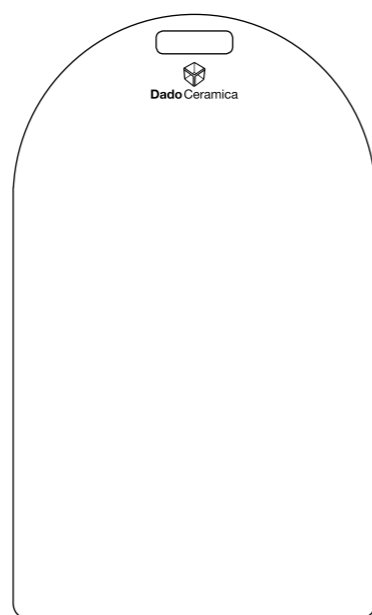

Faesite serie Beauty Matt

cm 47x80

beauty line

Rivestimento in bicottura
 Double-fired wall tiles
 Revêtement bicuisson
 Zweibrandverfahren Wandfliese

12,5x33,3 - 25x33,3
 5"x13" - 10"x13"



Gloss



300029/27 07
Snow
25x33,3 18



300540/30 11
Gloss
25x33,3 18



301091/30 12
Sahara
25x33,3 18

Spuma



300546/37 54
Spuma
12,5x33,3 24



300585/66 69
Mosaico Spuma
12,5x33,3 24



200842/09 26
Bacchetta Argento
0,6x33,3 36

Gres Porcellanato

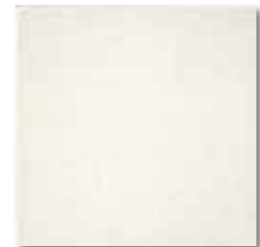

R02446/32 66
Cristallo HR
31x31 14

Beige



301089/38 49
Beige
12,5x33,3 24

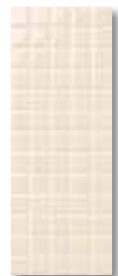

301162/66 69
Mosaico Beige
12,5x33,3 24



201178/09 26
Bacchetta Oro
0,6x33,3 36



R02447/32 66
Corda HR
30,5x30,5 14

Caffè



301090/46 59
Caffè
12,5x33,3 24

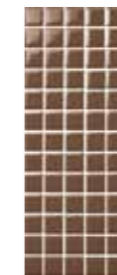

301163/80 70
Mosaico Caffè
12,5x33,3 24



201177/08 25
Bacchetta Caffè
0,6x33,3 36

Gres Porcellanato



R02454/32 66
Moka HR
30,5x30,5 14

Marea



300550/46 59
Marea
12,5x33,3 24



300586/80 70
Mosaico Marea
12,5x33,3 24



200839/08 25
Bacchetta Turchese
0,6x33,3 36



301618/32 66
Turchese HR
33,3x33,3 14

Rimmel



300548/46 59
Rimmel
12,5x33,3 24

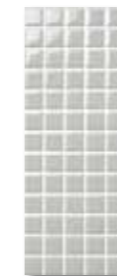

300589/80 70
Mosaico Rimmel
12,5x33,3 24



200841/08 25
Bacchetta Grigio
0,6x33,3 36



R02445/32 66
Grigio HR
31x31 14



pesi e misure / weight and sizes / poids et mesures / Gewichte und Verpackungen							
dimensioni sizes dimensions abmessungen	spessore thickness épaisseur stärke	pz/collo pcs/box pc/boite stk/ktn	mq/collo sqm/box m/boite qm/ktn	kg/collo kg/box kg/boite kg/ktn	colli/europal box/europal boites/europal ktn/europal	mq/europal sqm/europal m/europal qm/europal	kg/europal kg/europal kg/europal kg/europal
Fondo 12,5x33,3	8 mm	24	1	14	60	60	840
Fondo 25x33,3	7,6 mm	18	1,50	20	51	76,5	1020
Mosaico 12,5x33,3	8 mm	24	1	14	60	60	865
Pavimento HR 30,5x30,5	9 mm	14	1,30	23,10	72	93,6	1680
Pavimento HR 31x31	9 mm	14	1,35	24,00	72	97,20	1750
Pavimento HR 33,3x33,3	9 mm	14	1,55	28,50	48	74,40	1372

note / notes / notes / notes

12,5x33,3 modulare tagliato dal 25x33,3 preinciso
12,5x33,3 module cut from 25x33,3 precut / 12,5x33,3 module coupé du 25x33,3 précoupé / 12,5x33,3 modul geschnitten vom 25x33,3 Vorgeschnitten.

Per la posa del 12,5x33,3 in abbinamento e non al 25x33,3 ed al mosaico, è necessaria una fuga di almeno 2 mm.
For the laying of the 12,5x33,3 tiles it is advisable to leave a joint of at least 2 mm, especially when used with 25x33,3 tiles and with mosaics.
Pour la pose du format 12,5x33,3, spécialement coordonné au 25x33,3 et à la mosaïque, il est nécessaire un joint d'au moins 2 mm.
Für die Verlegung der 12,5x33,3 Fliesen, im besonderen mit den Fliesen 25x33,3 und dem Mosaik ist eine Fuge von 2 mm notwendig.



Bordeaux

		
300960/54 74 ■	301010/91 75 ■	201206/09 26 ■
Bordeaux	Mosaico Bordeaux	Bacchetta Granato
12,5x33,3 24 ☞	12,5x33,3 24 ☞	0,6x33,3 36 ☞

Gres Porcellanato

R02453/33 77 ■
Granato HR PEI IV
30,5x30,5 14 ☞

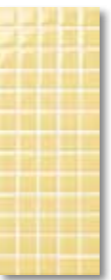

Soleil

		
300578/46 59 ■	300590/80 70 ■	200923/08 25 ■
Soleil	Mosaico Soleil	Bacchetta Soleado
12,5x33,3 24 ☞	12,5x33,3 24 ☞	0,6x33,3 36 ☞

Gres Porcellanato



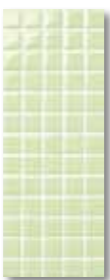

R02449/33 77 ■
Soleado HR PEI IV
30,5x30,5 14 ☞

Felce

		
300549/46 59 ■	300588/80 70 ■	200840/08 25 ■
Felce	Mosaico Felce	Bacchetta Muschio
12,5x33,3 24 ☞	12,5x33,3 24 ☞	0,6x33,3 36 ☞





R01944/32 ● 66 ■
Muschio HR PEI IV
25x25 18 ☞

Naranja *

		
300678/46 59 ■	300669/80 70 ■	201019/08 25 ■
Naranja	Mosaico Naranja	Bacchetta Naranja
12,5x33,3 24 ☞	12,5x33,3 24 ☞	0,6x33,3 36 ☞





R02198/40 ● 15 ■
Melon HR PEI III
25x25 18 ☞

Fard

		
300547/46 59 ■	300587/80 70 ■	200838/08 25 ■
Fard	Mosaico Fard	Bacchetta Fuxia
12,5x33,3 24 ☞	12,5x33,3 24 ☞	0,6x33,3 36 ☞

R02440/32 66 ■
Fuxia HR PEI IV
30,5x30,5 14 ☞

Scarlet *

		
300591/54 74 ■	300592/91 75 ■	200946/09 26 ■
Scarlet	Mosaico Scarlet	Bacchetta Karmin
12,5x33,3 24 ☞	12,5x33,3 24 ☞	0,6x33,3 36 ☞

R02456/40 15 ■
Karmin HR PEI III
31x31 18 ☞

pesi e misure / weight and sizes / poids et mesures / Gewichte und Verpackungen							
dimensioni sizes dimensions abmessungen	spessore thickness épaisseur stärke	pz/collo pcs/box pc/boite stk/ktn	mq/collo sqm/box m/boite qm/ktn	kg/collo kg/box kg/boite kg/ktn	colli/europal box/europal boites/europal ktn/europal	mq/europal sqm/europal m/europal qm/europal	kg/europal kg/europal kg/europal kg/europal
Fondo 12,5x33,3	8 mm	24	1	14	60	60	840
Fondo 25x33,3	7,6 mm	18	1,50	20	51	76,5	1020
Mosaico 12,5x33,3	8 mm	24	1	14	60	60	865
Pavimento HR 25x25	9 mm	18	1,125	21,30	80	90	1710
Pavimento HR 30,5x30,5	9 mm	14	1,30	23,10	72	93,6	1680
Pavimento HR 31x31	9 mm	14	1,35	24,00	72	97,20	1750

note / notes / notes / anmerkungen



12,5x33,3 modulare tagliato dal 25x33,3 preinciso
12,5x33,3 module cut from 25x33,3 precut / 12,5x33,3 module coupé du 25x33,3 précoupé / 12,5x33,3 modul geschnitten vom 25x33,3 Vorgeschritten.

Per la posa del 12,5x33,3 in abbinamento e non al 25x33,3 ed al mosaico, è necessaria una fuga di almeno 2 mm.
For the laying of the 12,5x33,3 tiles it is advisable to leave a joint of at least 2 mm, especially when used with 25x33,3 tiles and with mosaics.
Pour la pose du format 12,5x33,3, spécialement coordonné au 25x33,3 et à la mosaïque, il est nécessaire un joint d'au moins 2 mm.
Für die Verlegung der 12,5x33,3 Fliesen, im besonderen mit den Fliesen 25x33,3 und dem Mosaik ist eine Fuge von 2 mm notwendig.



* **Questi prodotti potrebbero presentare la caratteristica puntinatura del rosso al selenio.**
These products may present the typical dots of red colour obtained from Selenium / Ces produits pourraient présenter la piqûre caractéristique du rouge de sélénium / Diese Produkte könnten die typischen roten Selenium-Farbkörner aufweise

● **Ad esaurimento verrà prodotto nel formato 31x31**
Will be produced in the 31x31 size while stocks last / En cas d'épuisement, il sera produit dans le format 31x31 / Restbestand, wird in Zukunft im Format 31x31 hergestellt

Africa

		
301005/46 59 ■	301006/80 70 ■	200988/08 25 ■
Africa 24 ☞	Mosaico Africa 24 ☞	Bacchetta Africa 36 ☞
12,5x33,3	12,5x33,3	0,6x33,3

Gres Porcellanato

	
R02400/33 ● 77 ■	301067/113 71 ■
Nero HR PEI III 18 ☞	Mosaico Nero 5x5 HR 12 ☞
25x25	30,5x30,5

Mosaici 12,5 x 33,3

ISTRUZIONI PER LA POSA. Per ottenere risultati estetici ottimali, i mosaici 12,5x33,3, vanno posati mantenendo le piastrelle tutte nella stessa direzione (vedi disegno sotto riportato)
LAYING INSTRUCTIONS. In order to achieve the best aesthetic results, the mosaics 12,5x33,3 should be laid down maintaining the same direction for all the tiles (see the pictures herewith attached)
INSTRUCTIONS POUR LA POSE. Pour obtenir les meilleurs résultats esthétiques, les mosaïques 12,5x33,3 doivent être posées suivant la même direction pour tous les carreaux (voir dessin ci-joint)
VERLEGGUNGSANWEISUNGEN. Um vorzügliche ästhetische Ergebnisse zu erreichen, wird empfohlen die Mosaïke 12,5x33,3 in derselben Richtung zu verlegen (siehe Abbildung unten)

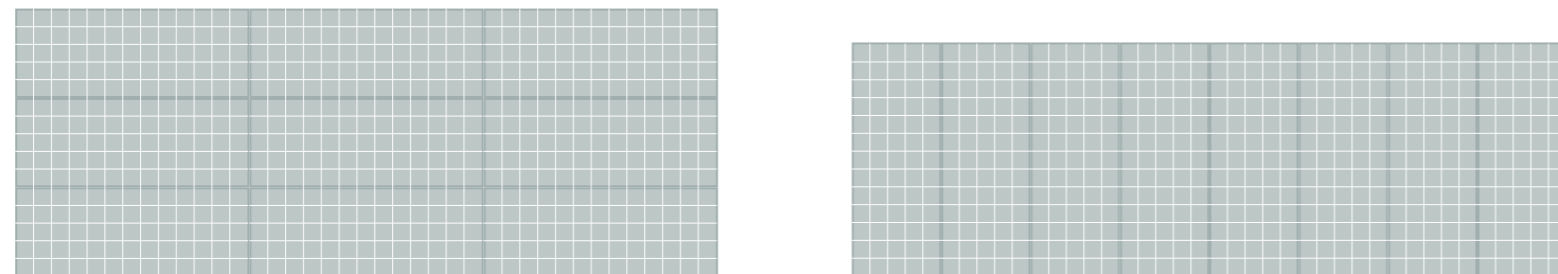

note / notes / notes / anmerkungen

12,5x33,3 modulare tagliato dal 25x33,3 preinciso
12,5x33,3 module cut from 25x33,3 precut / 12,5x33,3 module coupé du 25x33,3 pré-coupé / 12,5x33,3 modul geschnitten vom 25x33,3 Vorgeschnitten.













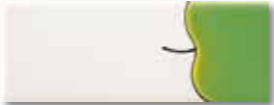

Per la posa del 12,5x33,3 in abbinamento e non al 25x33,3 ed al mosaico, è necessaria una fuga di almeno 2 mm.
For the laying of the 12,5x33,3 tiles it is advisable to leave a joint of at least 2 mm, especially when used with 25x33,3 tiles and with mosaics.
Pour la pose du format 12,5x33,3, spécialement coordonné au 25x33,3 et à la mosaïque, il est nécessaire un joint d'au moins 2 mm.
Für die Verlegung der 12,5x33,3 Fliesen, im besonderen mit den Fliesen 25x33,3 und dem Mosaik ist eine Fuge von 2 mm notwendig.

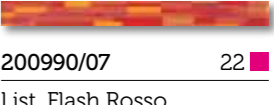
● Ad esaurimento verrà prodotto nel formato 31x31
Will be produced in the 31x31 size while stocks last / En cas d'épuisement, il sera produit dans le format 31x31 / Restbestand, wird in Zukunft im Format 31x31 hergestellt

pesi e misure / weight and sizes / poids et mesures / Gewichte und Verpackungen

dimensioni sizes dimensions abmessungen	spessore thickness épaisseur stärke	pz/collo pcs/box pc/boite stk/ktn	mq/collo sqm/box m/boite qm/ktn	kg/collo kg/box kg/boite kg/ktn	colli/euopal box/euopal boites/euopal ktr/euopal	mq/euopal sqm/euopal m/euopal qm/euopal	kg/euopal kg/euopal kg/euopal kg/euopal
Fondo 12,5x33,3	8 mm	24	1	14	60	60	840
Fondo 25x33,3	7,6 mm	18	1,50	20	51	76,5	1020
Mosaico 12,5x33,3	8 mm	24	1	14	60	60	865
Pavimento HR 25x25	9 mm	18	1,125	21,30	80	90	1710
Pavimento Mosaico HR 30,5x30,5	9 mm	14	1,30	23,10	72	93,6	1680

Decori / Decorations / Décorations / Dekors

			
201260/13 37 ■	201120/40 15 ■	201316/27 46 ■	200989/06 19 ■
Zebra 12 ☞	List. Mirror Marea 12 ☞	Dundee 12 ☞	Flash 24 ☞
12,5x33,3	12,5x33,3	8,5x33,3	12,5x33,3
			
201063/30 11 ■	200992/25 04 ■	201102/17 43 ■	200990/07 22 ■
Florance 12 ☞	Semifrutta (misti 2 pz.) 12 ☞	Lunch (misti 2 pz.) 12 ☞	List. Flash Rosso 24 ☞
12,5x33,3	12,5x33,3	12,5x33,3	3x33,3
			
200848/23 48 ■	200847/23 48 ■	200863/18 40 ■	201053/23 48 ■
Tulip Turchese 12 ☞	Tulip Fuxia 12 ☞	Essenza (misti 2 pz.) 12 ☞	Gerbera 12 ☞
12,5x33,3	12,5x33,3	12,5x33,3	12,5x33,3
			
200986/24 03 ■	200942/23 48 ■	200849/23 48 ■	201328/16 51 ■
Orchidea (misti 2 pz.) 12 ☞	Poppy (misti 2 pz.) 12 ☞	Dalia Grigio (misti 3 pz.) 12 ☞	Fleur (misto 3 pz.) 12 ☞
12,5x33,3	12,5x33,3	12,5x33,3	12,5x33,3



TT0527 Espositore serie Beauty Line

cm 38x115x143	1
Pannelli cm 38x118	6



TTP004 Pannello Sinottico serie Beauty Line

cm 100x200

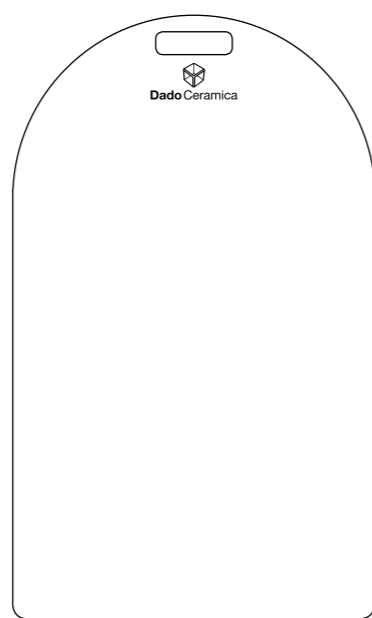

Faesite serie Beauty Line

cm 47x80

dolce amore

Rivestimento in bicottura
 Double-fired wall tiles
 Revêtement bicuisson
 Zweibrandverfahren Wandfliese

20x20
 8"x8"



Rivestimento in bicottura / Double-fired wall tiles
Revêtement biccuisson / Zweibrandverfahren Wandfliese

Vede

302511/30 11 ■
Love Verde
20x20 30201525/04 47 ■
Sigaro Sweet Verde
1,1x20 50801024/09 27 ■
Torello London Sweet Verde
3,5x20 18801028/18 40 ■
Spigolo London Sweet Verde
3,5x3,5 4302507/40 15 ■
Sweet Verde
20x20 30801020/13 37 ■
Battistraccio con sguscia
Sweet Verde 20x20 29

Azzurro

302510/30 11 ■
Love Azzurro
20x20 30201524/04 47 ■
Sigaro Sweet Azzurro
1,1x20 50801023/09 27 ■
Torello London Sweet Azzurro
3,5x20 18801027/18 40 ■
Spigolo London Sweet Azzurro
3,5x3,5 4302506/40 15 ■
Sweet Azzurro
20x20 30801019/13 37 ■
Battistraccio con sguscia
Sweet Azzurro 20x20 29

Rosa

302509/30 11 ■
Love Rosa
20x20 30201523/04 47 ■
Sigaro Sweet Rosa
1,1x20 50801022/09 27 ■
Torello London Sweet Rosa
3,5x20 18801026/18 40 ■
Spigolo London Sweet Rosa
3,5x3,5 4302505/40 15 ■
Sweet Rosa
20x20 30801018/13 37 ■
Battistraccio con sguscia
Sweet Rosa 20x20 29

Giallo

302512/30 11 ■
Love Giallo
20x20 30201526/04 47 ■
Sigaro Sweet Giallo
1,1x20 50801025/09 27 ■
Torello London Sweet Giallo
3,5x20 18801029/18 40 ■
Spigolo London Sweet Giallo
3,5x3,5 4302508/40 15 ■
Sweet Giallo
20x20 30801021/13 37 ■
Battistraccio con sguscia
Sweet Giallo 20x20 29

Bianco

300525/24 03 ■
Panna
20x20 30

Decori / Decorations / Décorations / Dekors

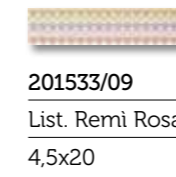
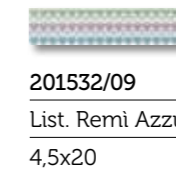
201533/09 27 ■
List. Remi Rosa
4,5x20 12201534/15 39 ■
List. Cip Giallo (misto 2 pz.)
9x20 6201535/15 39 ■
List. Cip Rosa (misto 2 pz.)
9x20 6201532/09 27 ■
List. Remi Azzurro
4,5x20 12201536/15 39 ■
List. Petit Azzurro
9x20 6201537/15 39 ■
List. Petit Verde
9x20 6

Gres Porcellanato Pavimenti consigliati / Suitable floor tiles / Carreaux pour sol coordonnés / Bodenfliesen-empfehlung

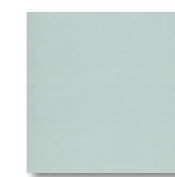
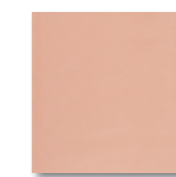
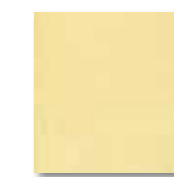
302515/27 07 ■
Kiss Verde
20x20 30302516/27 07 ■
Kiss Azzurro
20x20 30302517/27 07 ■
Kiss Rosa
20x20 30302517/27 07 ■
Kiss Giallo
20x20 30

pesi e misure / weight and sizes / poids et mesures / Gewichte und Verpackungen

dimensioni sizes dimensions abmessungen	spessore thickness épaisseur stärke	pz/collo pcs/box pc/boite stk/ktn	mq/collo sqm/box m/boite qm/ktn	kg/collo kg/box kg/boite kg/ktn	colli/euopal box/euopal boites/euopal ktn/euopal	mq/euopal sqm/euopal m/euopal qm/euopal	kg/euopal kg/euopal kg/euopal kg/euopal
Fondo 20x20	76 mm	30	1,20	16,40	95	114	1590



TT0925 Espositore serie Dolce Amore
 cm 139x93x61 1
 Pannelli cm 52x135 4

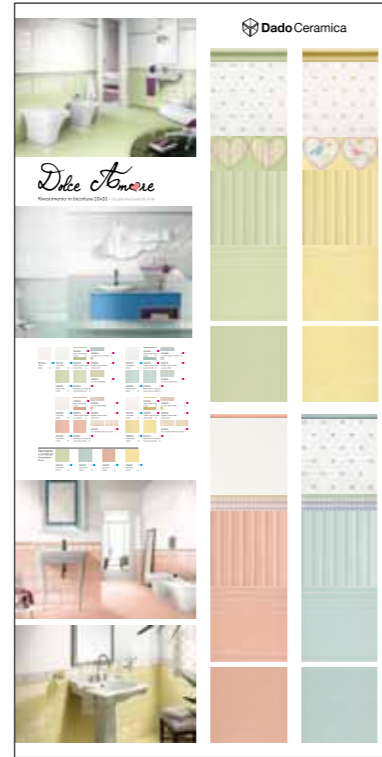

TTP066 Pannello Sinottico
 serie Dolce Amore
 cm 100x200

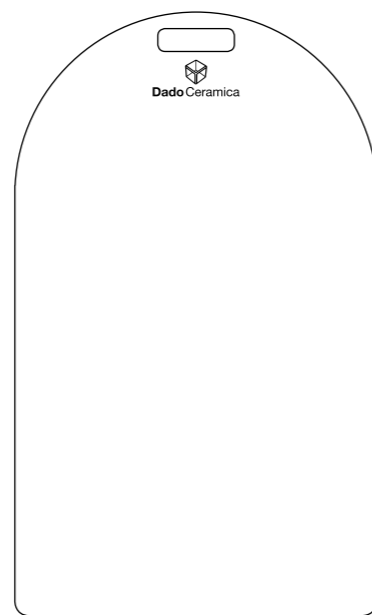

Faesite serie Dolce Amore
 cm 47x87















seta

Rivestimento in bicottura
 Double-fired wall tiles
 Revêtement bicuisson
 Zweibrandverfahren Wandfliese

20x20
 8"x8"



Fondi / Base tiles / Fonds / Grundfliesen

















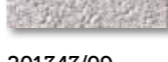

 301113/29 10 ■ Lamè Bianco 20x20 28	 301114/29 10 ■ Lamè Beige 20x20 28	 301116/29 10 ■ Lamè Lilla 20x20 28	 301115/30 12 ■ Lamè Antracite 20x20 28	 301099/30 12 ■ Lamè Caffè 20x20 28
 301109/29 10 ■ Seta Bianco 20x20 28	 301110/29 10 ■ Seta Beige 20x20 28	 301112/29 10 ■ Seta Lilla 20x20 28	 301111/30 12 ■ Seta Antracite 20x20 28	 301129/30 12 ■ Seta Caffè 20x20 28
 301117/31 13 ■ Mosaico Seta Bianco 20x20 28	 301118/31 13 ■ Mosaico Seta Beige 20x20 28	 301120/31 13 ■ Mosaico Seta Lilla 20x20 28	 301119/31 13 ■ Mosaico Seta Antracite 20x20 28	 301130/31 13 ■ Mosaico Seta Caffè 20x20 28

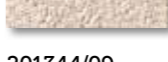
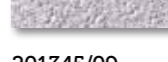
Gres Porcellanato Pavimenti consigliati / Suitable floor tiles / Carreaux pour sol coordonnés / Bodenfliesen-empfehlung

 R02446/32 66 ■ Cristallo HR PEI IV 31x31 14	 R02447/32 66 ■ Corda HR PEI IV 30,5x30,5 14	 R02442/32 66 ■ Ghisa HR PEI IV 30,5x30,5 14	 R02454/32 66 ■ Moka HR PEI IV 30,5x30,5 14	 301617/32 66 ■ Lilla HR PEI IV 33,3x33,3 14
---	---	---	--	---

pesi e misure / weight and sizes / poids et mesures / Gewichte und Verpackungen							
dimensioni sizes dimensions abmessungen	spessore thickness épaisseur stärke	pz/collo pcs/box pc/boite stk/ktn	mq/collo sqm/box m/boite qm/ktn	kg/collo kg/box kg/boite kg/ktn	colli/europal box/europal boites/europal ktn/europal	mq/europal sqm/europal m/europal qm/europal	kg/europal kg/europal kg/europal kg/europal
Fondo 20x20 - Mosaico 20x20	9 mm	28	1,12	16	95	106,4	1520
Pavimento HR 30,5x30,5	9 mm	14	1,30	23,10	72	93,6	1680
Pavimento HR 31x31	9 mm	14	1,35	24,00	72	97,20	1750
Pavimento HR 33,3x33,3	9 mm	14	1,55	28,50	48	74,40	1372

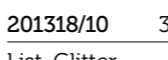
Decor / Decorations / Décorations / Dekors

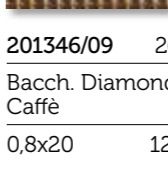
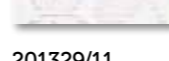
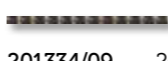
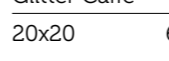
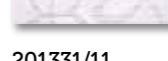
 001019/80 la comp. 70 ■ Comp. Bloom Bianco 40x40 comp. 3	 001020/80 la comp. 70 ■ Comp. Bloom Beige 40x40 comp. 3	 001021/80 la comp. 70 ■ Comp. Bloom Lilla 40x40 comp. 3		
 001002/27 46 ■ Glitter Bianco 20x20 6	 001022/11 33 ■ Glossy Bianco 20x20 18	 001001/27 46 ■ Glitter Beige 20x20 6	 001023/11 33 ■ Glossy Beige 20x20 18	 001024/11 33 ■ Glossy Lilla 20x20 18
 201320/10 31 ■ List. Glitter Bianco 3x20 24	 201343/09 26 ■ List. Glossy Bianco 4,5x20 12	 201317/10 31 ■ List. Glitter Beige 3x20 24	 201344/09 26 ■ List. Glossy Beige 4,5x20 12	 201345/09 26 ■ List. Glossy Lilla 4,5x20 12
 001008/22 42 ■ Melrose Bianco (misti) 20x20 12	 001003/27 46 ■ Glitter Antracite 20x20 6	 001006/17 43 ■ Funny Beige 20x20 12	 001028/17 43 ■ Funny Caffè 20x20 12	 001010/22 42 ■ Melrose Lilla (misti) 20x20 12
 201318/10 31 ■ List. Glitter Antracite 3x20 24	 201334/09 26 ■ Bacch. Diamond Antracite 0,8x20 12	 001027/27 46 ■ Glitter Caffè 20x20 6	 201333/09 26 ■ Bacch. Diamond Lilla 0,8x20 12	 201331/11 34 ■ List. Melrose Lilla (misti 4 Pz.) 6x20 12
 201329/11 34 ■ List. Melrose Bianco (misti 4 Pz.) 6x20 12	 201347/10 31 ■ List. Glitter Caffè 3x20 24	 201346/09 26 ■ Bacch. Diamond Caffè 0,8x20 12	 201331/11 34 ■ List. Melrose Lilla (misti 4 Pz.) 6x20 12	



unicolor



TT0816 Espositore serie Seta
cm 52x115x160 1
Pannelli cm 52x135 6

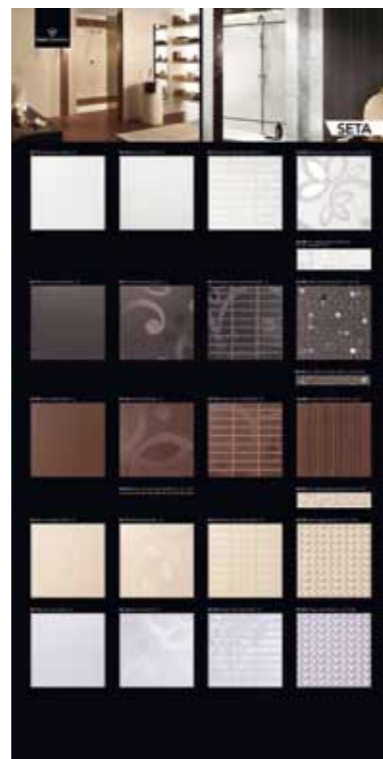

TTP027 Pannello Sinottico serie Seta
cm 100x200

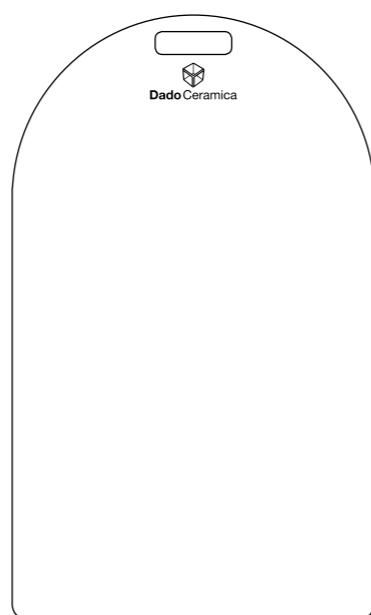









Faesite serie Seta
cm 47x87



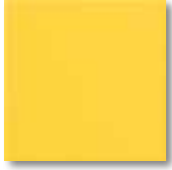





Rivestimento in bicottura
Double-fired wall tiles
Revêtement bicuisson
Zweibrandverfahren Wandfliese

20x20
8"x8"

Unicolor Matt

			
302789/19 53	302790/19 53	302791/19 53	302792/19 53
Bianco Matt	Beige Matt	Celeste Matt	Verde Matt
20x20 35	20x20 35	20x20 35	20x20 35
			
302793/19 53	302794/19 53	302795/19 53	302796/23 48
Giallo Matt	Blu Matt	Grigio Matt	Nero Matt
20x20 35	20x20 35	20x20 35	20x20 35

Unicolor Lux

			
302797/19 53	302798/19 53	302799/19 53	302800/19 53
Bianco Lux	Beige Lux	Celeste Lux	Verde Lux
20x20 35	20x20 35	20x20 35	20x20 35
			
302801/19 53	302802/19 53	302803/19 53	302804/23 48
Giallo Lux	Blu Lux	Grigio Lux	Rosso Lux
20x20 35	20x20 35	20x20 35	20x20 35

302809/19 53
Ondulato Bianco
20x20 35

sale e pepe

Pavimento in gres fine porcellanato smaltato a tutta massa

Full body porcelain stoneware floor tile
 Revêtement de sol en grès cérame fin pleine masse
 Bodenbelag aus vollgemischtem Feinsteinzeug

30,5x30,5
 12"x12"

pesi e misure / weight and sizes / poids et mesures / Gewichte und Verpackungen							
dimensioni sizes dimensions abmessungen	spessore thickness épaisseur stärke	pz/collo pcs/box pc/boite stk/ktn	mq/collo sqm/box m/boite qm/ktn	kg/collo kg/box kg/boite kg/ktn	colli/europal box/europal boites/europal ktn/europal	mq/europal sqm/europal m/europal qm/europal	kg/europal kg/europal kg/europal kg/europal
Fondo 20x20 Matt/Lux	7 mm	35	1,40	15	76	106,40	1160

Colori / Colour / Couleurs / Farben



301503/14 38 ■
Sale e Pepe Beige PEI IV
30,5x30,5 15



301504/15 39 ■
Sale e Pepe Brown PEI IV
30,5x30,5 15



301505/14 38 ■
Sale e Pepe Silver PEI IV
30,5x30,5 15



301502/15 39 ■
Sale e Pepe Graphite PEI IV
30,5x30,5 15



301639/14 38 ■
Sale e Pepe Grey PEI IV
30,5x30,5 15

hard rocks

Gres porcellanato smaltato
Glazed porcelain stoneware
Grès cérame émaillé
Glasiertes Feinsteinzeug

25x25 - 30,5x30,5 - 30,5x61
10"x10" - 12,2"x12,2" - 12,2"x24,4"

pesi e misure / weight and sizes / poids et mesures / Gewichte und Verpackungen							
dimensioni sizes dimensions abmessungen	spessore thickness épaisseur stärke	pz/collo pcs/box pc/boite stk/ktn	mq/collo sqm/box m/boite qm/ktn	kg/collo kg/box kg/boite kg/ktn	colli/europal box/europal boites/europal ktn/europal	mq/europal sqm/europal m/europal qm/europal	kg/europal kg/europal kg/europal kg/europal
Fondo 30,5x30,5	7 mm	15	1,39	21,25	72	100,08	1550

33,3x33,3 - 31x31 - 30,5x30,5 - 25x25 13"x13" - 12"x12" - 12"x12" - 10"x10"



R02447/32 66 ■
Corda HR PEI IV
30,5x30,5 14



R02449/33 77 ■
Soleado HR PEI IV
30,5x30,5 14



R02440/32 66 ■
Fuxia HR PEI IV
30,5x30,5 14



301617/32 66 ■
Lilla HR PEI IV
33,3x33,3 14



R02453/33 77 ■
Granato HR PEI IV
30,5x30,5 14



301618/32 66 ■
Turchese HR PEI IV
33,3x33,3 14



R02458/33 77 ■
Acquamarina HR PEI IV
30,5x30,5 14



R02385/32 66 ■
Menta HR PEI IV
30,5x30,5 14



R02198/40 ★● 15 ■
Melon HR PEI III
25x25 18



R02456/40 ★ 15 ■
Karmin HR PEI III
31x31 18



R01944/32 ● 66 ■
Muschio HR PEI IV
25x25 18



R02454/32 66 ■
Moka HR PEI IV
30,5x30,5 14



R02445/32 66 ■
Grigio HR PEI IV
31x31 14



R02442/32 66 ■
Ghisa HR PEI IV
30,5x30,5 14

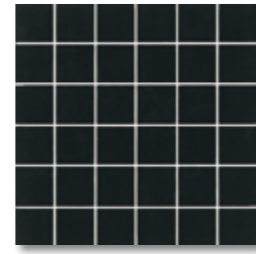

301067/113 71 ■
Mosaico Nero PEI IV
5x5 HR
30,5x30,5 (su rete) 12



R02457/33 77 ■
Avion HR PEI IV
30,5x30,5 14



R02446/32 66 ■
Cristallo HR PEI IV
31x31 14



R02548/32 66 ■
Tortora HR PEI IV
30,5x30,5 14



R01761/32 ● 66 ■
Bronzo HR PEI IV
25x25 18



R02400/33 ● 77 ■
Nero HR PEI III
25x25 18

R02288/33 ● 77 ■
Avion HR PEI IV
25x25 18

pesi e misure / weight and sizes / poids et mesures / Gewichte und Verpackungen							
dimensioni sizes dimensions abmessungen	spessore thickness épaisseur stärke	pz/collo pcs/box pc/boite stk/ktn	mq/collo sqm/box m/boite qm/ktn	kg/collo kg/box kg/boite kg/ktn	colli/europal box/europal boites/europal ktn/europal	mq/europal sqm/europal m/europal qm/europal	kg/europal kg/europal kg/europal kg/europal
Pavimento HR 25x25	9 mm	18	1,125	21,30	80	90	1710
Pavimento HR 30,5x30,5	9 mm	14	1,30	23,10	72	93,60	1680
Mosaico HR 30,5x30,5	9 mm	12	1,1163	19	63	70,33	1220
Pavimento HR 31x31	9 mm	14	1,35	24,00	72	97,20	1750
Pavimento HR 33,3x33,3	9 mm	14	1,55	28,50	48	74,40	1372

31x31 - 31x62 12"x12" - 12"x24"



R02384/27 91 ■
Polvere HR PEI IV
31x31 14

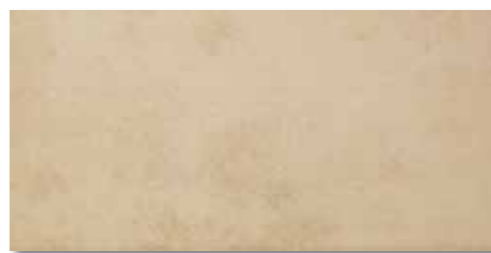

R02405/35 96 ■
Polvere HR PEI IV
31x62 7

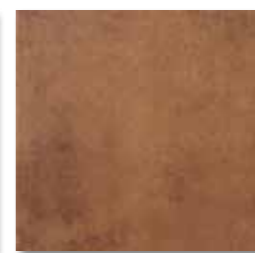

R02382/27 91 ■
Terra HR PEI IV
31x31 14



R02408/35 96 ■
Terra HR PEI IV
31x62 7



R02383/27 91 ■
Ghiaia HR PEI IV
31x31 14



R02407/35 96 ■
Ghiaia HR PEI IV
31x62 7

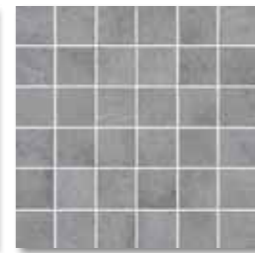

301068/113 71 ■
Mosaico Ghiaia PEI IV
5x5 HR
31x31 (su rete) 12

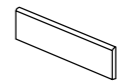

Battiscopa 7,5x31 46 ■
R02396/04 Polvere 47 ■
R02397/04 Terra 47 ■
R02398/04 Ghiaia 47 ■
R02399/04 Carbone 47 ■



R02381/27 91 ■
Carbone HR PEI IV
31x31 14



R02406/35 96 ■
Carbone HR PEI IV
31x62 7

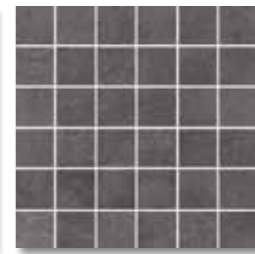

301069/113 71 ■
Mosaico Carbone PEI IV
5x5 HR
31x31 (su rete) 12

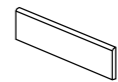

Battiscopa 7,2x62 20 ■
R02416/07 Polvere 22 ■
R02427/07 Terra 22 ■
R02426/07 Ghiaia 22 ■
R02425/07 Carbone 22 ■

pesi e misure / weight and sizes / poids et mesures / Gewichte und Verpackungen							
dimensioni sizes dimensions abmessungen	spessore thickness épaisseur stärke	pz/collo pcs/box pc/boite stk/ktn	mq/collo sqm/box m/boite qm/ktn	kg/collo kg/box kg/boite kg/ktn	colli/europal box/europal boites/europal ktn/europal	mq/europal sqm/europal m/europal qm/europal	kg/europal kg/europal kg/europal kg/europal
Pavimento HR 31x31	9 mm	14	1,35	22	72	97,20	1600
Pavimento HR 31x62	9 mm	7	1,35	22	60	81	1340
Mosaico HR 31x31	9 mm	12	1,1163	16,40			
Battiscopa 7,5x31	9 mm	46	14,03 ml.	16,80			
Battiscopa 7,2x62	9 mm	20	14,03 ml.	16,80			

note / notes / notes / notes

I nostri pavimenti in gres porcellanato presentano caratteristiche di produzione tali per cui richiedono una fuga di 3 mm in fase di posa e risulta necessario prelevare alternativamente le piastrelle da più scatole della medesima tonalità per ottenere la giusta seminatura.

Our porcelain have production characteristics requiring a 3 mm. laying joint; it's necessary to take the tiles alternately from more than one box of the same colour in order to obtain the right "seminato" effect.

Nos sols en Grès Cérame présentent des caractéristiques de production telles qu'ils exigent un jointoiment de 3 mm durant la pose. Il est en outre nécessaire de prélever alternativement les carreaux de plusieurs boîtes du même ton, afin d'obtenir le bon "seminato" effet.

Aus herstellungstechnischen Gründen benötigen unsere Bodenbeläge aus Feinsteinzeug beim Verlegen eine Fuge von 3 mm, und die Fliesen müssen abwechselnd aus mehreren Schachteln mit demselben Farbton entnommen werden, um die richtige "Seminato-Effekt" zu erzielen.

★ Questi prodotti potrebbero presentare la caratteristica puntinatura del rosso al selenio.
These products may present the typical dots of Red colour obtained from Selenium.

● Ad esaurimento verrà prodotto nel formato 31x31
Will be produced in the 31x31 size while stocks last / En cas d'épuisement, il sera produit dans le format 31x31 / Restbestand, wird in Zukunft im Format 31x31 hergestellt

caratteristiche tecniche



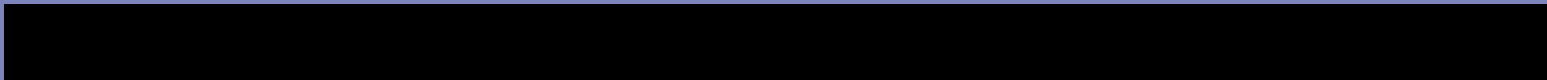
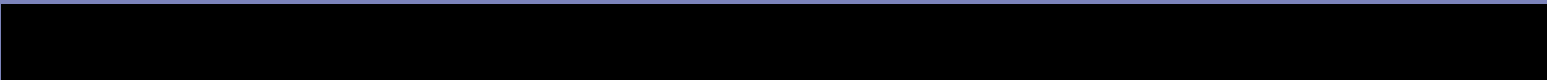





technical characteristics
caractéristiques techniques
technische merkmale

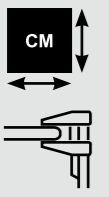

Gres porcellanato

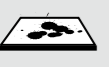
Porcelain stoneware / Grès cérame / Feinsteinzeug







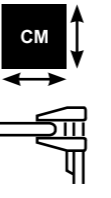

caratteristiche tecniche - technical characteristics - caractéristiques techniques - technische merkmale
UNI EN 14411 BIa Allegato G (ISO 13006)

Caratteristica tecnica Technical feature Caractéristique technique Technische eigenschaft	Norma Norms Norme Norme	Valore richiesto dalle norme Required standards Valeur prescrite par les normes Normvorgabe	DADO CERAMICA
 Assorbimento d'acqua Water absorption Absorption d'eau Wasseraufnahme	UNI EN ISO 10545-3	≤ 0,5%	≤ 0,5%
 Resistenza alla flessione Bending strength Résistance à la flexion Biegefestigkeit	UNI EN ISO 10545-4	≥ 35 N/mm ²	Conforme Corresponding Conforme Entsprechend
 Resistenza al gelo Resistance to frost Résistance aux gel Frostbeständigkeit	UNI EN ISO 10545-12	Nessuna alterazione No alteration Aucune alteration Keine Veränderung	Non gelivo Frost-proof Non gélifs Frostsicher
 Caratteristiche di regolarità Regularity characteristics Caractéristiques de régularité Regelmäßigkeit	UNI EN ISO 10545-2	Lunghezza e larghezza / Length and width Longueur et largeur / Länge und breite	± 0,6% max
		Spessore / Thickness Épaisseur / Stärke	± 5% max
		Rettilinearità spigoli / Straightness of sides Rectitude des arêtes / Kantengeradheit	± 0,5% max
		Ortogonalità / Rectangularity Orthogonalité / Rechtwinkligkeit	± 0,6% max
		Planarità / Length and width Longueur et largeur / Ebenflächigkeit	± 0,5% max
 Tolleranze minime Low alteration Minime alteration Geringe Veränderung	UNI EN ISO 10545-2	Lunghezza e larghezza / Length and width Longueur et largeur / Länge und breite	± 0,6% max
		Spessore / Thickness Épaisseur / Stärke	± 5% max
		Rettilinearità spigoli / Straightness of sides Rectitude des arêtes / Kantengeradheit	± 0,5% max
		Ortogonalità / Rectangularity Orthogonalité / Rechtwinkligkeit	± 0,6% max
 Resistenza all'abrasione (metodo PEI) Wear resistance (PEI test) Résistance à l'abrasion (méthode PEI) Widerstand gegen Abrieb (nach PEI)	UNI EN ISO 10545-7	Come dichiarato	≥ 3
 Resistenza alle macchie Staining resistance Résistance aux taches Widerstand gegen fleckenbildung	UNI EN ISO 10545-14	Min. 3	Conforme Corresponding Conforme Entsprechend
 Stabilità dei colori Colours stability Stabilité des couleurs Farbbeständigkeit	DIN 51094	Stabile	Nessuna Variazione
 Durezza Superficie Mohs Mohs surface hardness Dureté de la surface (échelle Mohs) Ritzhärte nach Mohs	UNI EN 101	≥ 6	6-8
 Resistenza agli sbalzi termici Thermal shock resistance Résistance aux écarts de température Temperaturwechselbeständigkeit	ISO 10545-9	Metodo di prova disponibile Test method available Méthode d'essai disponible Prüfverfahren verfügbar	Resiste Resistant
 Resistenza allo scivolamento Slip resistance Résistance au glissement Rutschemmende Eigenchaft	METODO B.C.R.A. DIN 51130 DIN 51097	D.M.I. Giugno 1989 n. 236 (μ > 0,40) In funzione dell'ambiente o della zona di lavoro Basing on the environment or on the working area In funzione delle zone bagnate soggette a calpestio a piedi scalzi Basing on the wet-loaded barefoot areas	> 0,4

Bicottura

Double-fired / Bicuison / Zweibrand

caratteristiche tecniche - technical characteristics - caractéristiques techniques - technische merkmale
UNI EN 14411 BIII Allegato L (ISO 13006)

Caratteristica tecnica Technical feature Caractéristique technique Technische eigenschaft	Norma Norms Norme Norme	Valore richiesto dalle norme Required standards Valeur prescrite par les normes Normvorgabe	DADO CERAMICA
 Caratteristiche di regolarità Regularity characteristics Caractéristique technique Regelmäßigkeit	UNI EN ISO 10545-2	Lunghezza e larghezza / Length and width Longueur et largeur / Länge und breite	± 0,5%
		Spessore / Thickness Épaisseur / Stärke	± 10%
		Ortogonalità / Rectangularity Orthogonalité / Rechtwinkligkeit	± 0,50%
		Planarità / Length and width Longueur et largeur / Ebenflächigkeit	- 0,30% + 0,50%
 Assorbimento d'acqua Water absorption Absorption d'eau Wasseraufnahme	UNI EN ISO 10545-3	> 10	15%
 Resistenza alla flessione Bending strength Résistance à la flexion Biegefestigkeit	UNI EN ISO 10545-4	≤ 7,5 mm > 7,5 mm	15 N/mm ² 12 N/mm ²
 Coefficiente espansione termica lineare Thermal expansion coefficient Coefficient de dilatation linéaire Koeffizient der linearen thermischen Dehnung	UNI EN ISO 10545-8		Conforme Corresponding Conforme Entsprechend
 Resistenza al cavillo Grazing resistance Résistance au tresillage Haarißbeständigkeit	UNI EN ISO 10545-11	Richiesta Requested Demandée Gefragt	Conforme Corresponding Conforme Entsprechend
 Resistenza agli sbalzi termici Thermal shock resistance Résistance aux écarts de température Temperaturwechselbeständigkeit	UNI EN ISO 10545-9		Conforme Corresponding Conforme Entsprechend
 Resistenza agli acidi Chemical resistance Résistance à l'attaque chimique Beständigkeit gegen Chemikalien	UNI EN ISO 10545-13		Conforme Corresponding Conforme Entsprechend
 Resistenza alle macchie Staining resistance Résistance aux taches Widerstand gegen fleckenbildung	UNI EN ISO 10545-14	Classe 3 Class 3 Classe 3 Klasse 3	Conforme Corresponding Conforme Entsprechend

vario

various - informations utiles - andere



Concessione PT.0113 Gruppo di prodotto BIII GL

Concessione PT.0241 Gruppo di prodotto BIa GL

Dado Ceramica S.r.l. ha richiesto ed ottenuto il Diritto d'uso del marchio Certiquality-UNI, marchio rilasciato da Certiquality (Istituto di Certificazione). Il marchio attesta la conformità alle prescrizioni della normativa UNI EN dei prodotti che Dado Ceramica ha deciso di sottoporre a certificazione. (La lista è a disposizione). La concessione del marchio è subordinata all'ottenimento dell'idoneità delle metodologie e dei controlli effettuati su tutto il ciclo produttivo, rilasciata dall'organismo di ispezione dopo la verifica del Sistema di Qualità aziendale. Deve essere inoltre riconosciuta la conformità, da parte del Laboratorio di Prova (Centro Ceramico di Bologna), a tutte le caratteristiche tecniche delle piastrelle ceramiche, che devono rientrare nei requisiti fissati dalle varie norme di prodotto.

La Certificazione di Qualità UNI è applicata solamente alle piastrelle di I^a scelta. Durante il mantenimento del Marchio, l'Organismo di Ispezione UNI effettua periodicamente verifiche del Sistema di Qualità interno e della sua corretta gestione.

Dado Ceramica ha ottenuto le concessioni:

- CONCESSIONE PT. 0113 Gruppo di Prodotto BIII GL. Norma corrispondente UNI EN 14411 allegato L.
- CONCESSIONE PT. 0241 Gruppo di Prodotto BIa GL. Norma corrispondente UNI EN 14411 allegato G.

Dado Ceramica S.r.l. a demandé et obtenu le Droit d'utilisation de la Marque Certiquality-UNI, un label attribué par Certiquality (L'Institut de Certification). Le label atteste la conformité aux prescriptions de la réglementation UNI EN des produits que Dado Ceramica a décidé de soumettre à la certification. (La liste est à votre disposition.)

L'octroi du label dépend de l'obtention de l'aptitude des méthodologies et des contrôles effectués sur tout le cycle de production, remise par l'Organisme d'Inspection après la vérification du Système de Qualité de l'Entreprise.

Il faut également que le Laboratoire d'Essai (Centro Ceramico di Bologna) ait reconnu la conformité à toutes les caractéristiques techniques des carreaux céramiques, qui doivent être dans les limites établies par les différentes normes de produit.

La Certification de Qualité UNI n'est appliquée qu'aux carreaux de 1er choix.

Pendant la période de maintien du Label, l'Organisme d'Inspection UNI effectue périodiquement des contrôles du Système de Qualité interne et de sa gestion correcte.

Dado Ceramica a obtenu les concessions :

- CONCESSIONE PT. 0113 Groupe de Produit BIII GL. Norme correspondante UNI EN 14411-L.
- CONCESSIONE PT. 0241 Groupe de Produit BIa GL. Norme correspondante UNI EN 14411-G.

Dado Ceramica S.r.l. has applied for and obtained Certiquality-UNI certification, the mark issued by the Institute of Certification. The mark proves compliance of the products which Dado Ceramica has decided to submit for certification, with the provisions of the UNI EN body of regulations. (The list is at your disposal).

Concession of the mark is subject to obtaining certification of the methodologies and controls applied to the entire productive cycle, issued by the inspection body after controls on the company Quality System. Conformity of the ceramic tiles to all the technical characteristics, which must comply with the requirements established by the various product standards, must also be confirmed by the Test Laboratory (Centro Ceramico di Bologna). The UNI Quality Certification is only applied to 1ST choice tiles. During the period of concession of the Mark, the UNI Inspection Body carries out periodic controls of the internal Quality System and its proper management.

Dado Ceramica has obtained the concessions:

- CONCESSION PT. 0113 Product Group BIII GL. Corresponding standard: UNI EN 14411-L.
- CONCESSION PT. 0241 Product Group BIa GL. Corresponding standard: UNI EN 14411-G.

Dado Ceramica S.r.l. hat die Bescheinigung Certiquality-UNI, ein Prüfzeichen, das von der Zulassungsbehörde ausgestellt wird, beantragt und erhalten. Dieses Prüfzeichen bescheinigt die Übereinstimmung mit den Vorschriften der Norm UNI EN aller Produkte, die Dado Ceramica der Zulassungsprüfung unterziehen will. (Die Liste ist zu Ihrer Verfügung).

Die Bewilligung des Prüfzeichens setzt die Erlangung der Zulässigkeit der Methoden und Kontrollen des gesamten Herstellungszyklus voraus und wird vom Kontrollorgan nach der Überprüfung des firmeneigenen Qualitätssystems ausgestellt. Außerdem muss die Konformität vom Prüflabor (Centro Ceramico di Bologna) allen technischen Eigenschaften der Keramikfliesen zuerkannt werden, die den Anforderungen der verschiedenen Produktnormen entsprechen müssen.

Die Qualitätsbescheinigung UNI besteht nur für Fliesen 1. Wahl. Während der Beibehaltung des Prüfzeichens überprüft das Kontrollorgan UNI in regelmäßigen Zeitabständen das firmeninterne Qualitätssystem und seine korrekte Durchführung.

Dado Ceramica hat die Zulassungen:

- ZULASSUNG PT. 0113 Produktgruppe BIII GL. Zuständige Norm UNI EN 14411-L.
- ZULASSUNG PT. 0241 Produktgruppe BIa GL. Zuständige Norm UNI EN 14411-G.

CONSIGLI DI POSA

Non si accettano reclami relativi a materiale già posato.

Per una posa eseguita a regola d'arte è richiesta, in generale, l'osservanza dei seguenti criteri:

1. Resistenze adeguate del sottofondo;
2. Rispetto dei tempi di maturazione del massetto;
3. Posa in ambienti di sole civili abitazioni. Applicazioni diverse dovranno essere sottoposte a verifica di DADO CERAMICA srl;
4. Rispetto degli eventuali giunti strutturali presenti;
5. Realizzazione di giunto elastico perimetrale, per ogni elemento in elevazione, con limitazione delle superfici continue a non oltre 50-60 m (25-30 m in presenza di grandi vetrate);
6. Utilizzo di opportuno adesivo di classe C2 (per interno) o C2E (per esterno) secondo EN 12004, utilizzando la tecnica della doppia spalmatura;
7. Utilizzo di idoneo stucco avendo cura di effettuare prove preventive di pulibilità in caso di stuccature a contrasto;
8. All'atto della posa prelevare piastrelle alternativamente da diverse scatole;
9. Controllare, prima della posa, tonalità, calibro e scelta.

Il prodotto rettificato consente anche di ottenere una superficie in cui la giunzione fra una lastra e l'altra è appena percettibile (minimo **2/3 mm**).

Nell'utilizzo del prodotto naturale si consiglia una fuga di **4/5 mm** tra una lastra e l'altra.

ADVICE FOR INSTALLATION

We cannot accept complaints made after the material has been installed. To achieve a state-of-the-art installation the following criteria must be observed:

1. Adequate sub-base resistance;
2. Respect of the slab setting times;
3. Installation in residential environments only. Any different applications must be examined by DADO CERAMICA srl;
4. Respect of any existing structural joints;
5. Realization of expansion joint for the perimeter, for all raised elements, with limitation of continuous surfaces to no more than 50-60 sqm (25-30 sqm in areas containing large window/glass installations or when used externally);
6. The use of a suitable C2 (for interior use) or C2E (for external use) adhesive according to EN12004, applied with the double spread coating technique;
7. The use of a suitable grout, checked and tested first, in the case of contrasting grout, and tested in a small area to verify that it can be effectively cleaned away;
8. During laying, pick tiles alternately from different boxes;
9. Check that the calibre, shade and sorting grade are correct before installing.

Rectified products also enable to obtain surfaces where joints are hardly perceptible (minimum **2/3 mm**).

For the natural finish, a joint of **4/5 mm** is recommended between one tile and the next.

CONSEILS DE POSE

Aucune réclamation portant sur des matériaux déjà posés ne sera acceptée. Pour une pose dans les règles de l'art, il convient d'une manière générale de respecter les conditions suivantes:

1. Résistance adaptée de la sous-couche;
2. Respect des temps de maturation de la chape;
3. Pose uniquement dans des habitations civiles. Toute autre application sera soumise au contrôle de DADO CERAMICA srl;
4. Respect des éventuels joints structurels présents;
5. Réalisation d'un joint élastique périphérique, pour chaque élément surélevé, avec limitation des surfaces continues à un maximum de 50-60 m (25-30 m en présence de grandes baies vitrées);
6. Utilisation d'une colle adaptée de classe C2 (pour intérieur) ou C2E (pour extérieur) conformément à la norme EN 12004, en utilisant la technique du double encollage;
7. Utilisation d'un ciment-joint adapté en prenant soin de vérifier préalablement qu'il peut être nettoyé en cas de joints en contraste;
8. Lors de la pose, prélever les carreaux en alternant entre différents paquets;
9. Avant de procéder à la pose, contrôler la teinte, le calibre et l'aspect du carreau.

Le produit rectifié permet également d'obtenir une surface où la jonction entre une dalle et l'autre est à peine perceptible (**2/3 mm** minimum). Lors de l'utilisation du produit avec surface naturelle, il est conseillé de respecter un joint de **4/5 mm** entre chaque dalle.

VERLEGEHINWEISE

Es werden keine Reklamationen bezüglich von bereits verlegtem Material akzeptiert. Um nach allen Regeln der Kunst zu verlegen, müssen allgemein folgende Kriterien eingehalten werden:

1. Angemessene Widerstandsfähigkeit des Untergrunds;
2. Einhaltung der Reifungszeiten des Estrichs;
3. Verlegung in ausschließlich aus Zivilwohnungen bestehenden Umgebungen. Andere Anwendungsarten müssen von DADO CERAMICA srl überprüft werden;
4. Einhaltung eventuell vorhandener Bauwerksfugen;
5. Errichtung einer Dehnungsrandfuge für jedes erhöhte Element mit Beschränkung der durchgehenden Flächen auf maximal 50-60 m (25-30 m, falls große Glasflächen vorhanden sind);
6. Verwendung eines geeigneten Klebers der Klasse C2 (für den Innenbereich) oder C2E (für den Außenbereich) nach EN 12004 unter Anwendung der Technik des zweifachen Kleberaufstrichs;
7. Verwendung eines geeigneten Fugenmittels, wobei man im Fall von kontrastierenden Fugen zuvor Reinigungstests durchführen sollte;
8. Bei der Verlegung die Fliesen abwechselnd aus verschiedenen Schachteln verwenden;
9. Vor dem Verlegen den Farbton, die Größenklasse und die Wahl kontrollieren.

Mit dem geschliffenen Produkt kann man auch eine Fläche mit einer kaum wahrnehmbaren Fuge zwischen den einzelnen Platten erzielen (mindestens **2-3 mm**). Bei Verwendung des naturbelassenen Produkts wird empfohlen, eine **4-5 mm** breite Fuge zwischen den einzelnen Platten einzuhalten.



ALL' ATTENZIONE DEL POSATORE

DISTANZIATORE LIVELLANTE S.A.P.2 LA SOLUZIONE PER UNA POSA PERFETTA

Gentile cliente/posatore,
le aziende ceramiche hanno immesso sul mercato pavimenti e rivestimenti di grandi formati rettificati che necessitano di una posa più specifica e accurata.

Il **distanziatore livellante S.A.P.2** è nato per migliorare la messa in opera delle piastrelle e semplificare il lavoro del posatore ottenendo così un prodotto finito esteticamente perfetto.

Per questo motivo **Dado Ceramica** consiglia di posare con il **distanziatore livellante S.A.P.2** per prevenire gli inconvenienti che possono presentarsi durante la posa.

In particolare il **distanziatore livellante S.A.P.2**:

- Allinea piastrelle di diverso spessore
- Elimina il dislivello tra le piastrelle
- Assicura una fuga minima di 2mm
- Non necessita di alcuno strumento aggiuntivo
- Diminuisce le contestazioni
- Risultati professionali

Per maggiori informazioni visita il sito www.andalsystem.it oppure contatta i nostri tecnici **096 2431436**

PRIMA



DOPO



1



Posizionare due o più tiranti al di sotto della piastrella a circa 10 cm dagli angoli.
Posizionare la piastrella successiva.

2



Far scivolare il cuneo all'interno del tirante, spingendo con forza fino all'allineamento delle piastrelle.

3



Una volta indurito il collante sarà sufficiente un calcio in linea di fuga sul tirante per eliminarlo.



TO THE ATTENTION OF INSTALLER

S.A.P.2 LEVELING SPACERS: THE BEST SOLUTION FOR A PERFECT INSTALLATION

Dear customer/installer,
large-format rectified porcelain produced by ceramic factories needs a more precise and accurate installation.

The **SAP2 leveling spacer** is designed to improve the tile installation and oversimplify the work of the installer and achieve an excellent result.

For all these reasons, **Dado Ceramica** recommends to install tiles with the **SAP2 leveling spacer** in order to prevent inconveniences which may occur during the installation.

In particular, the **SAP2 leveling spacer**:

- Aligns tiles of different thicknesses,
- Virtually eliminates lippage,
- Allows a minimum joint of 0,07" (2mm)
- No special tools are required
- Decreases call-backs due to poor installation.
- Professional results

For further information please visit our website www.andalsystem.it or contact our specialists **+39 096 2431436**

BEFORE



AFTER



1



1. Slide two clips under the tile and into the mortar approximately 2" from each end of the tile.
Place the second tile.

2



Slide the reusable wedges into the hole at the top of the clip, pushing it as tight as possible. Check for the alignment of the grout joints and move on to the next tile.

3



Once the mortar sets, simply kicks the clips in the same direction as the grout joints and it will break off at the base

CONSIGLI PER LA PULIZIA DOPO POSA E MANUTENZIONE

dei pavimenti in gres porcellanato **naturali** e **lappati** Dado Ceramica srl

All'attenzione del posatore: Prima pulizia

La cura con la quale si esegue la pulizia dopo posa influenzerà la pulibilità del pavimento per tutta la sua durata.

Importantissimo è pulire bene a fine posa, a pavimento nuovo. È necessario infatti, dopo aver applicato il fugante, togliere tutti i residui di cemento lasciati in fase di posa e stuccatura dai posatori con l'utilizzo di acido tamponato (tipo Keranet o similari). Lasciare agire per circa 40 minuti e poi risciacquare bene con appositi strumenti aspira liquidi fino a vedere l'acqua utilizzata limpida. A seguire effettuare un lavaggio con un prodotto sgrassante leggermente alcalino (tipo sgrassatore per cappe da cucina o tipo Chante Clair) ed un buon risciacquo. Dopo queste operazioni la messa in servizio del pavimento è terminata a regola d'arte.

ATTENZIONE: Si consiglia di utilizzare fuganti non additivati con polimeri. In caso di utilizzo di questa tipologia si prega di pulire immediatamente con un detergente alcalino.

Se queste operazioni non vengono effettuate correttamente il pavimento conserverà un invisibile strato di calcare che col tempo si potrà macchiare o impedire una pulizia profonda.

Fatto questo e avuta la certezza che le piastrelle siano ben pulite, il pavimento non presenterà problemi. Se però la pulizia iniziale non è stata eseguita correttamente ed il pavimento presenta aloni, macchie o piastrelle con superficie opacizzata è possibile rimediare ripartendo dalla prima pulizia, cioè utilizzando un detergente a base acida e risciacquando ripetutamente con acqua pulita, in quanto non esistono detergenti in grado di pulire all'istante e al solo passaggio un pavimento così sporco.

Manutenzione e pulizia ordinaria

Si consiglia l'utilizzo di acqua e aceto una volta al mese per asportare il calcare che inevitabilmente si deposita sul pavimento durante le normali operazioni di pulizia.

Per la pulizia quotidiana è sufficiente utilizzare, con moderazione, un detergente neutro a basso residuo, prodotti acquistabili nei supermercati. È importante sciacquare spesso il panno utilizzato nella pulizia e non eccedere nella quantità di detergente, infatti l'uso di acqua sporca, prodotti auto lucidanti o eccesso di detergenti può formare, col tempo, una patina invisibile causa di aloni e macchie.

Di norma, i produttori consigliano di provare i loro detergenti su una piccola porzione nascosta del pavimento o del rivestimento prima di utilizzarli su tutta la superficie da trattare.

Nel caso di uso accidentale o volontario di prodotti chimici (detergenti, acidi o solventi), seguire attentamente le istruzioni d'uso previste per ogni prodotto, in particolare si suggerisce di effettuare una prova su una piccola porzione nascosta della superficie da trattare e comunque deve sempre seguire un abbondante risciacquo e accurata asciugatura.

ATTENZIONE: di fondamentale importanza è non utilizzare mai smacchiatori tipo antiruggine o di tipo spray perché contengono acido fluoridrico, il danno che provocherà sarà irreversibile ed irreparabile in quanto non esiste pavimento resistente a tale acido.

Cleaning after installation and for maintenance

ADVICE FOR CLEANING AFTER INSTALLATION AND FOR MAINTENANCE of Dado Ceramica srl **natural** and **lapped** porcelain stoneware floor tiles

For installers: initial cleaning

Careful, scrupulous cleaning of new floors after installation will make them easier to clean for the rest of the time thereafter, so it is extremely important.

After the grout has been applied, all the cement residue left behind at the installation and grouting stage must be removed using buffered acid (such as Keranet or similar).

Leave the acid to work for about 40 minutes, then rinse thoroughly using suitable wet vacuum devices until the water runs clear.

After this, wash using a slightly alkaline degreasing product (such as the type used for kitchen hoods, Chante Clair or similar) and rinse carefully.

The flooring is now perfectly ready for use.

N.B.: We recommend using grout without polymer additives. If this type of grout is used, cleaning must be carried out immediately using an alkaline detergent.

If these operations are not carried out correctly, the floor will retain an invisible layer of limescale which in time may become soiled or prevent proper cleaning.

Once this has been done and you are sure the tiles have been properly cleaned, there will be no problems with the floor. If, however, this initial cleaning has not been carried out properly and there are shades or stains on the floor, or tiles with a dull surface, the problem can be solved by starting out from the initial cleaning process, i.e. using an acid-based detergent and rinsing repeatedly with clean water, because no detergent is able to clean such a dirty floor in just one go.

Ordinary cleaning and maintenance

Water and vinegar should be used once a month to remove the limescale that inevitably settles on the floor during normal cleaning operations.

For everyday cleaning, it is sufficient to use a moderate amount of neutral, low-residue detergent, which can be purchased in supermarkets.

It is important to rinse the cloth used for cleaning frequently, and not to use too much detergent; in time, dirty water, self-polishing products or too much detergent can leave an invisible patina to form that causes shades and stains. Manufacturers generally recommend testing their detergents on a small section of floor or wall hidden from view before using it on the whole surface to be treated. If chemicals (detergents, acids or solvents) are used either accidentally or voluntarily, carefully follow the instructions provided for the product in question. We suggest trying products out on a small section hidden from view of the surface to be treated, and in all cases the surface must be thoroughly rinsed and dried.

N.B.: spray stain removers or rust removers must never be used, because they contain hydrofluoric acid, which causes irreversible, irreparable damage to all kinds of flooring.

Nettoyage après la pose et entretien

CONSEILS DE NETTOYAGE APRÈS LA POSE ET D'ENTRETIEN des revêtements de sol en grès cérame **naturels** et **polis** Dado Ceramica srl

À l'attention de la personne en charge de la pose: Premier nettoyage

Le soin apporté au nettoyage une fois la pose achevée a une incidence sur la nettoyabilité du revêtement de sol pendant toute sa durée d'utilisation. Il est fondamental de procéder à un nettoyage correct du nouveau revêtement de sol une fois la pose achevée. Après le remplissage des joints, éliminer tous les résidus de ciment laissés lors de la pose et du remplissage des joints par les personnes en charge de la pose en utilisant de l'acide tamponné (type Keranet ou produit similaire). Laisser agir pendant environ 40 minutes puis rincer avec soin à l'aide d'outils adaptés d'aspiration de liquide, jusqu'à ce que l'eau utilisée soit limpide. Procéder ensuite à un nettoyage avec un produit dégraissant légèrement alcalin (comme un dégraissant pour hottes de cuisine ou un produit de type Chante Clair) et rincer convenablement. Une fois ces opérations réalisées, la mise en service du revêtement de sol est considérée comme achevée dans les règles de l'art.

ATTENTION: il est recommandé d'utiliser des produits de jointolement sans additifs polymères. En cas d'utilisation de ce type de produits, nettoyer immédiatement avec un produit de nettoyage alcalin.

Si ces opérations ne sont pas réalisées correctement, une couche de calcaire invisible demeurera sur le revêtement de sol qui, avec le temps, pourrait se tacher ou empêcher un nettoyage en profondeur. Une fois ces opérations réalisées et lorsque l'on a la certitude que les carreaux sont bien propres, le revêtement de sol ne présente plus aucun problème. Cependant, si le nettoyage initial n'a pas été réalisé correctement et si le revêtement de sol présente des auréoles, des taches ou des carreaux dont la surface est opaque, il est possible d'y remédier en recommençant du nettoyage initial. Utiliser alors un produit de nettoyage à base acide puis rincer de manière répétée à l'eau propre, dans la mesure où il n'existe pas de produits capables de nettoyer instantanément et en un seul passage un revêtement de sol présentant un tel degré de saleté.

Entretien et nettoyage ordinaire

Il est conseillé d'utiliser de l'eau et du vinaigre une fois par mois pour éliminer le calcaire qui se dépose inévitablement sur le revêtement de sol lors des opérations de nettoyage normales. Pour le nettoyage quotidien, il suffit d'utiliser, avec modération, un produit de nettoyage neutre à faible résidu, vendu couramment dans le commerce. Il est important de rincer régulièrement le linge utilisé pour le nettoyage et de ne pas utiliser une quantité excessive de produit de nettoyage. L'utilisation d'eau sale, de produits autolustrants ou d'une quantité excessive de produit nettoyant peut avec le temps entraîner la formation d'une patine invisible et l'apparition d'auréoles et de taches. Généralement, les fabricants recommandent d'essayer leurs produits de nettoyage sur une petite portion cachée du revêtement avant de les utiliser sur l'ensemble de la surface à nettoyer. En cas d'utilisation accidentelle ou volontaire de produits chimiques (produits de nettoyage, acides ou solvants), suivre attentivement les instructions d'utilisation de chaque produit, en particulier s'il est recommandé d'effectuer un essai sur une petite portion cachée de la surface à traiter, et toujours procéder à un rinçage abondant et à un séchage méticuleux.

ATTENTION: il est fondamental de ne jamais utiliser de détachants antirouille ou en spray, qui contiennent de l'acide fluorhydrique. Les dégâts causés seraient irréversibles et irréparables dans la mesure où il n'existe aucun revêtement de sol résistant à cet acide.

Reinigung nach dem Verlegen und Wartung

RATSCHLÄGE FÜR DIE REINIGUNG NACH DEM VERLEGEN UND DIE WARTUNG von naturbelassenen und geläpften Feinsteinzeugböden von Dado Ceramica srl

Für den Verleger: Erste Reinigung

Die Sorgfalt, mit der man die Reinigung nach dem Verlegen durchführt, wird die Reinigungsfähigkeit des Fußbodens während seiner gesamten Lebensdauer beeinflussen. Es ist sehr wichtig, den neuen Bodenbelag nach der Verlegung gut zu reinigen. So ist es notwendig, nach dem Auftragen der Fugenmasse alle beim Verlegen und Verfugen hinterlassenen Zementrückstände mit einer gepufferten Säure (der Art Keranet oder ähnlichem) zu entfernen. Ungefähr 40 Minuten lang einwirken lassen und dann gut mit geeigneter Ausrüstung zur Ansaugung von Flüssigkeiten spülen, bis das verwendete Wasser klar bleibt. Danach eine Reinigung mit einem leicht alkalischen Entfetter (der Art der Entfetter für Abzugshauben oder z.B. Chante Clair) ausführen und gut spülen. Nach diesen Vorgängen ist der Fußboden nach allen Regeln der Kunst für eine Inbetriebnahme bereit.

ACHTUNG: Es wird empfohlen, Fugenzmittel ohne Polymerzusätze zu verwenden. Bei Verwendung dieser Typologie wird empfohlen, sofort mit einem alkalischen Reinigungsmittel nachzureinigen.

Falls diese Vorgänge nicht korrekt durchgeführt werden, wird eine unsichtbare Kalkschicht auf dem Fußboden verbleiben, die mit der Zeit Flecken erzeugen oder eine tiefgehende Reinigung verhindern könnte. Nach diesen Maßnahmen und nachdem man sich vergewissert hat, dass die Fliesen gut gereinigt sind, wird der Fußboden keine Probleme aufweisen. Falls die Erstreinigung dagegen nicht korrekt ausgeführt wird und der Fußboden Schlieren, Flecken und Fliesen mit matter Oberfläche aufweist, kann man Abhilfe schaffen, indem man die Erstreinigung unter Verwendung eines Reinigungsmittels auf Säurebasis wiederholt und mehrmals mit sauberem Wasser nachspült, da es keine Reiniger mit sofortiger Wirkung gibt, die einen auf diese Weise verunreinigten Fußboden in einem Durchgang reinigen.

Normale Wartung und Reinigung

Es wird empfohlen, einmal im Monat Wasser mit Essig zu verwenden, um den Kalk zu entfernen, der sich unvermeidlich bei der normalen Reinigung auf dem Fußboden ablagert. Für die tägliche Reinigung ist es ausreichend, mit Maßen einen in Supermärkten erhältlichen Neutralreiniger mit geringem Rückstand zu verwenden. Es ist wichtig, das bei der Reinigung verwendete Tuch häufig auszuspülen und nicht mit der Reinigermenge zu übertreiben, da die Verwendung von schmutzigem Wasser, Reinigern mit Selbstglanzeffekt oder zu viel Reinigungsmittel mit der Zeit eine unsichtbare Patina bilden kann, die Schlieren und Flecken erzeugt. Normalerweise empfehlen die Hersteller, die Reiniger auf einer kleinen, verborgenen Stelle des Fußbodens oder der Verkleidung zu testen, bevor man sie auf der gesamten zu behandelnden Fläche einsetzt. Im Fall einer unabsichtlichen oder gewollten Verwendung von chemischen Produkten (Reiniger, Säuren oder Lösungsmittel), die Gebrauchsanweisungen für das jeweilige Produkt aufmerksam befolgen, insbesondere wird empfohlen, einen Test auf einer kleinen verborgenen Stelle der zu behandelnden Fläche auszuführen und in jedem Fall reichlich abzuspülen und sorgfältig zu trocknen.

ACHTUNG: Es ist von grundlegender Bedeutung, niemals Fleckentferner der Art Rostschutzmittel oder Sprays zu verwenden, da sie Fluorwasserstoffsäure enthalten, die irreversible Schäden verursachen, da es keinen Fußboden gibt, der dieser Säure widersteht.

Dado Ceramica: un servizio ineguagliabile!

Dado Ceramica: an outstanding service!
Dado Ceramica: un service irréprochable!
Dado Ceramica: ein ungläublicher Service!



Home

About Us

Services

Solutions

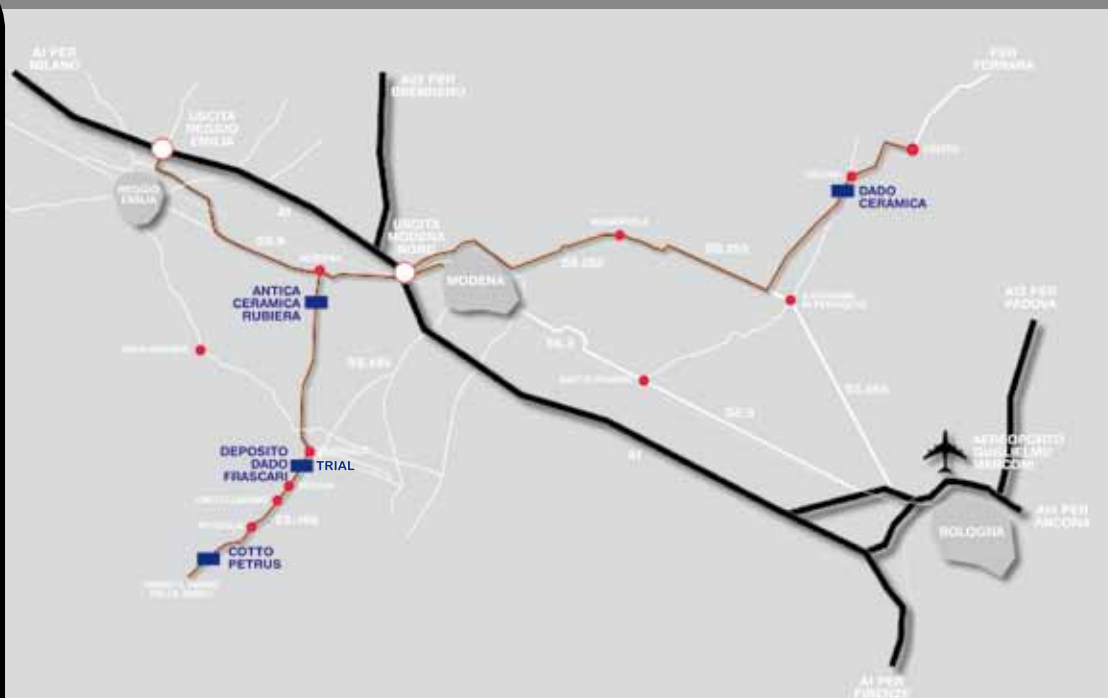

Nessuna spesa di magazzino per i prodotti che portiamo al nostro Deposito Frascari Adriano, via Radici in Piano, n. 116 Castellarano (R.E.)
Telefono +39-0536824747
Telefax +39-0536990195.
Tempi di attesa ridotti al minimo: i camion vengono prontamente caricati, in quanto c'è solo la merce delle aziende del nostro gruppo.

No extra storage charges for products we ship to our central warehouse Frascari Adriano, via Radici in Piano n. 116 Castellarano (R.E.)
Telefono +39-0536824747
Telefax +39-0536990195.
Shortest loading waiting time: the lorries are promptly loaded, because in our warehouse there are only the materials of the Dado group affiliated companies.

Aucun frais de stockage pour les produits que nous améons chez notre Dépôt Frascari Adriano, via Radici in Piano n. 116 Castellarano (R.E.)
Telefono +39-0536824747 -
Telefax +39-0536990195.
Temps d'attente réduits au minimum: vos routiers sont promptement chargés, car seulement la marchandise des usines de notre groupe y est traitée.

Keine Depotkosten für die Produkte, die wir zu unserem Lager Frascari Adriano, via Radici in Piano n.116 Castellarano (R.E.)
Telefono +39-0536824747
Telefax +39-0536990195.
Verminderte Wartezeit, wenn nur Ware von unserer Firmengruppe geladen wird, werden die LKW ohne lange Wartezeit sofort beladen.

Progettazione grafica

G&Co grafica e colore - Corlo MO

Stampa

Grafiche Pioppi

Si ringrazia per la gentile concessione delle locations:

TIMBERLAND® Store Modena - p. 8 (in basso) / Stefano COSATTO srl - p. 9 (in alto) / MORASSUTTI Arredamenti - Play srl - p. 14 (dx in alto) / BMT srl - p. 15 (in alto), p. 35 (dx in alto), 117 (in basso) / PUNTOTRE arredobagno - p. 16 (in alto), 37 (in alto), 127 (in basso), 139 / ARTCERAM srl - p. 16 (dx in basso), 184 (sx in alto), 190 (dx in basso) / SANTAROSSA spa - p. 17 (sx in alto), 63 (in basso) / DISEGNO CERAMICA srl p. 17 (dx in alto), 183 / GALASSIA spa - p. 17 (in basso), 56 (in basso), 91 (sx in basso), 137 (in basso), 138 (sx in alto), 175 (in alto) / REGIA srl - p. 26 (in basso), 136 (in alto), 138 (in basso), 159 (in alto), 172 (in basso), 173 (in alto), 174 (sx in alto), 175 (sx in basso), 196 (in basso) / RAB arredobagno srl - p. 29, 130, 136 (in basso), 158 (in alto), 173 (in basso), 182 (in alto) / SCANDOLA Mobili srl - p. 9 (dx in basso), p. 32 (sx in basso) / HIDRA Ceramica srl - p. 32 (sx in alto), 116 (in alto), 138 (dx in alto), 204, 257 (in basso), 256 (in alto) / FLLI BRANCHETTI srl - p. 32 (dx in basso) / Ceramica GLOBO spa - p. 33 (dx in alto), 34 (dx in basso), 192 (sx), 256 (in alto) / GB GROUP srl - p. 34 (sx in alto) / Q'IN Vetreria Gobbini srl - p. 36 (in alto), 66 (sx in basso), 117 (dx in alto) / TENDA DORICA - p. 57 (in alto), 174 (dx in alto), 174 (in basso), 175 (dx in basso), 184 (in basso) / NOVA LINEA srl - p. 57 (dx in basso) / MINACCIOLLO spa - p. 90 (in alto), 91 (dx in alto) / IOTTI by Menozzi Bagno srl - p. 116 (dx in basso), 127 (in alto) / EUROBAGNO srl - p. 172 (in alto) / ARCOM srl - p. 257 (in alto).

catalogo prodotti



Dado Ceramica

Pavimenti e Rivestimenti

40017 S.Matteo della Decima/Bologna/Italy/Via Sicilia 21

Telefono +39-0516819611/Telefax export +39-0516819650

Telefax Italia 0516819649

www.dadoceramica.it - info@dadoceramica.it

